

INSTALLATION INSTRUCTIONS

SIDEBAR
07 ACURA MDX
PART NUMBER

PARTS LIST:

2	Side Tubes with Steps (Driver & Passenger)	12	8-1.25mm x 25mm Hex Head Bolts
2	Front Mounting Brackets (Driver & Passenger)	12	8-1.25mm x 35mm Hex Head Bolts
2	Rear Mounting Brackets (Driver & Passenger)	24	8mm Lock Washers
4	Auxiliary Mounting Brackets	4	8mm Hex Nuts
2	12mm x 35mm T-Bolts	28	8mm ID x 22mm OD x 1.5mm Flat Washers
2	12mm Lock Washers		
2	12mm Hex Nuts		
2	12mm ID x 29mm OD x 3mm Flat Washers		

PROCEDURE

- 1. REMOVE CONTENTS FROM BOX. VERIFY ALL PARTS ARE PRESENT. READ INSTRUCTIONS CAREFULLY BEFORE STARTING INSTALLATION.**
- From underside of vehicle, locate the factory hole in the front driver side frame rail and insert (1) 12mm x 35mm T-Bolt. **NOTE:** This should line up to two factory threaded holes in the floor panel. Loosely attach the driver side front Mounting Bracket to already inserted T-Bolt using the included (1) 12mm Lock Washer, (1) 12mm Hex Nut, and (1) 12mm Flat Washer (**Figure 1 & 3**).
- Locate the two front factory threaded holes in the driver side floor panel. **NOTE:** These should line up with the previously installed front Mounting Bracket. Loosely attach one of the Auxiliary Mounting Brackets from the rear side of the front Mounting Bracket and with the 90° bend towards the front of the vehicle using the included (2) 8mm x 35mm Hex Bolts, (2) 8mm Lock Washers, and (2) 8mm Flat Washers (**Figure 1 & 3**).
- Attach front Mounting Bracket to Auxiliary Bracket using the included (1) 8mm x 25mm Hex Head Bolt, (1) 8mm Lock Washer, (1) 8mm Hex Nut, and (2) 8mm Flat Washers. Do not tighten at this time (**Figure 1 & 3**).
- Attach and secure Rear Mounting Bracket and Auxiliary Bracket in the same manner as the front. **NOTE:** The Auxiliary Bracket for the rear mounts in the front side of the rear Mounting Bracket and with the 90° bend towards the rear of the vehicle (**Figure 2 & 4**).
- Position driver Sidebar onto Mounting Bracket and attach it using the included (4) 8mm x 25mm Hex Head Bolts, (4) 8mm Lock Washers, and (4) 8mm Flat Washers (**Figure 3 & 4**).
- Align Sidebar properly, and then tighten all hardware at this time.
- Repeat steps 2 - 7 for the passenger Sidebar.
- Do periodic inspections to the installation to make sure that all hardware is secure and tight.

To protect your investment, wax this product after installing. Regular waxing is recommended to add a protective layer over the finish. Do not use any type of polish or wax that may contain abrasives that could damage the finish.

For stainless steel: Aluminum polish may be used to polish small scratches and scuffs on the finish. Mild soap may be used also to clean the Sidebar.

For gloss black finishes: Mild soap may be used to clean the Sidebar.

**Driver Side Front Mounting
Brackets Shown**

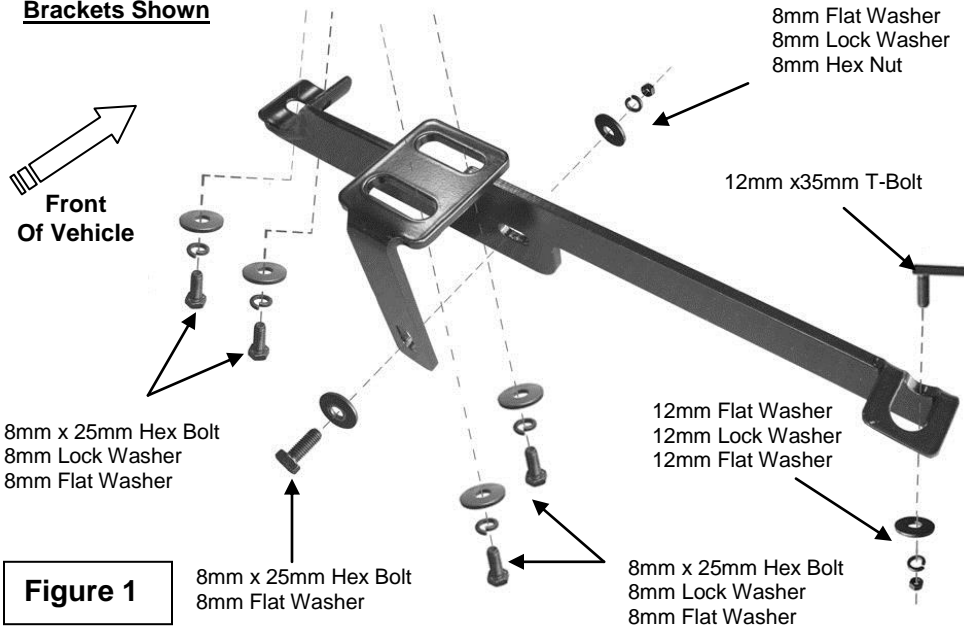

Figure 1

**Driver Side Rear Mounting
Brackets Shown**

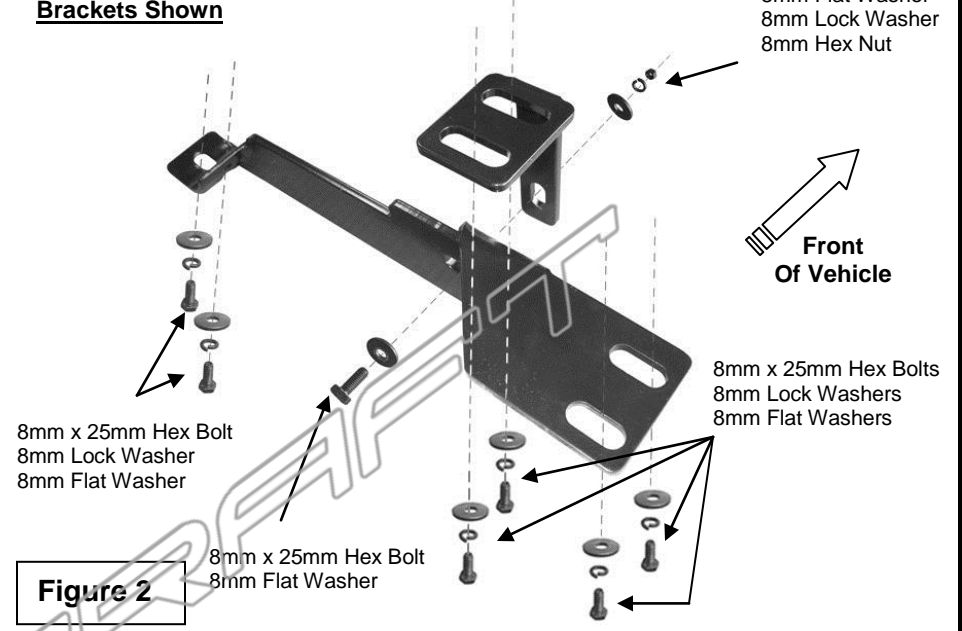

Figure 2

Driver Side Front Mounting Brackets Shown

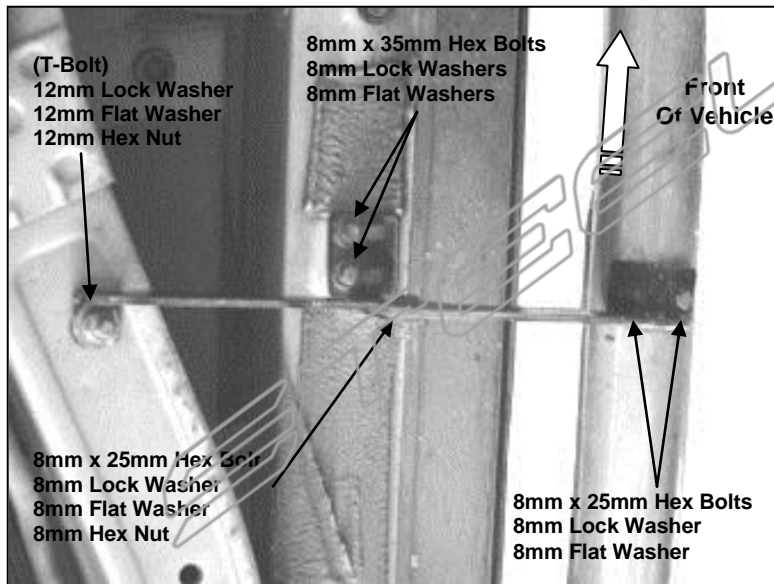

Figure 3

Driver Side Rear Mounting Brackets Shown

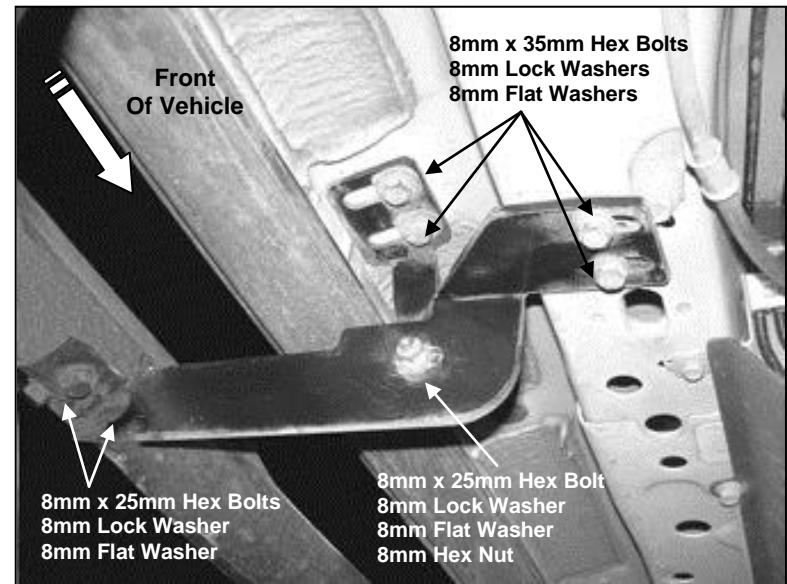

Figure 4