

**STX300 RUNNING BOARD**  
**99-15 FORD SUPERDUTY SUPER CAB AND CREW CAB**

**PARTS LIST:**

|    |   |    |                                  |
|----|---|----|----------------------------------|
| 6  | Universal Mounting Brackets (left of right) | 2  | 8-1.25mm Nylon Lock Nuts         |
| 10 | 8-1.25mm Clip-Nuts                          | 12 | 6mm T-Bolts                      |
| 12 | 8-1.25mm x 25mm Hex Bolts                   | 12 | 6mm x 22mm OD x 2mm Flat Washers |
| 14 | 8mm x 24mm x 2mm Flat Washer                | 12 | 6mm Lock Washers                 |
| 10 | 8mm Lock Washers                            | 12 | 6mm Hex Nuts                     |

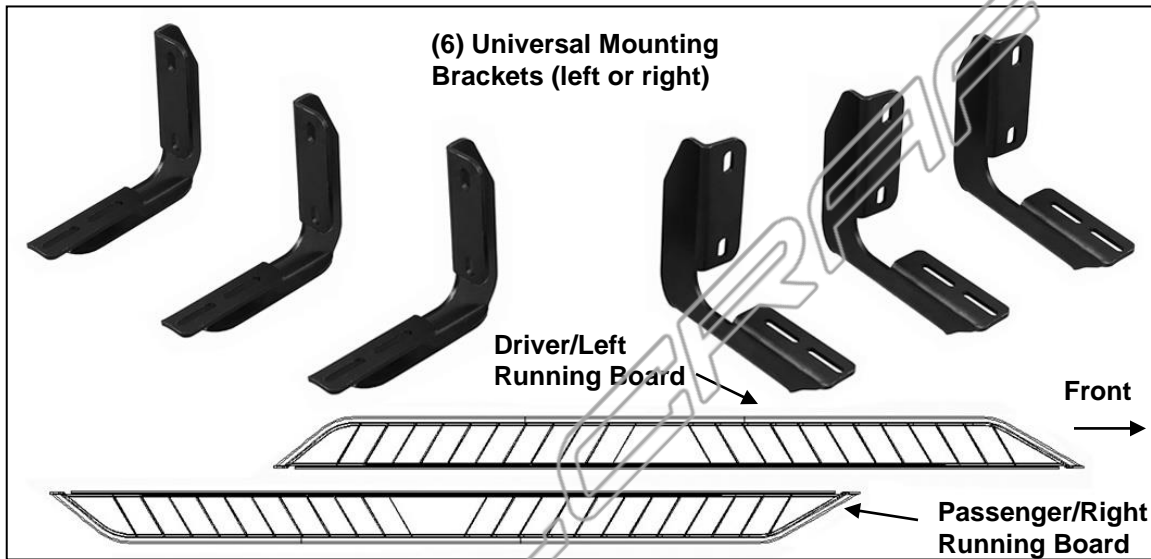

**PROCEDURE:**

1. REMOVE CONTENTS FROM BOX. VERIFY ALL PARTS ARE PRESENT. READ INSTRUCTIONS CAREFULLY BEFORE STARTING INSTALLATION.
2. Starting on the front-driver side of the vehicle, locate the (2) holes through the bottom of the body panel, (pinch weld). Next locate the rectangular opening and (2) small holes in the inner body panel directly above the holes in the pinch weld, **(Figures 1 & 2)**. **NOTE:** The holes in the inner panel may be covered with sealing tape or insulation, remove as required.
3. Slide (1) 8mm Clip Nut into the rectangular opening with the nut towards the inside. Line up the threaded nut on the clip with the round hole toward the rear, **(Figure 2)**.
4. Select (1) Mounting Bracket. Attach the top of the Bracket to the Clip Nut with (1) 8mm x 25mm Hex Bolt, (1) 8mm Lock Washer and (1) 8mm Flat Washer, **(Figure 3)**. Leave loose at this time. Line up the lower hole in the Bracket with the hole through the pinch weld. Bolt the Bracket to the pinch weld with (1) 8mm x 25mm Hex Bolt, (2) 8mm Flat Washers and (1) 8mm Nylon Lock Nut, **(Figure 3)**. **NOTE:** This will apply to the driver and passenger side front Bracket installation only. Snug but do not fully tighten Bracket hardware.
5. Move toward the center of the vehicle. Use the illustration on **Page 2** to determine the correct mounting location for the center Bracket, **(Figure 1)**. Select (2) 8mm Clip Nuts. Repeat **Steps 2 & 3** to install (1) Clip Nut in the correct top mounting hole. Slide the 2nd Clip Nut over the lower hole in the pinch weld. Select (1) Mounting Bracket. Attach the Bracket to the (2) Clip Nuts with (2) 8mm x 25mm Hex Bolts, (2) 8mm Lock Washers and (2) 8mm Flat Washers, **(Figures 4 & 5)**. Snug but do not fully tighten Bracket hardware.
6. Continue along the cab to the rear mounting location. Locate the last (2) mounting holes in the pinch weld towards the back of the cab, **(Figures 1 & 6)**. Use the illustration on **Page 2** to determine correct mounting location. Repeat **Step 5** to install (1) Bracket in the rear location, **(Figures 6 & 9)**.
7. Carefully unwrap the Running Boards. Select the driver side Running Board. **NOTE:** End with sharper angle is the front of the Running Board, (see **Page 1**). Locate the two channels in the bottom of the Running Board. Slide (3) T-Bolts into each channel, **(Figure 7)**.

## STX300 RUNNING BOARD 99-15 FORD SUPERDUTY SUPER CAB AND CREW CAB

8. Hold the Running Board up in approximate position and slide the T-Bolts down to line up with the Mounting Brackets. Tilt the Board up at a slight angle and push back against the vehicle until the T-Bolts fit into the slots on the Brackets.
9. Secure the Running Board to the Brackets with (6) 6mm Flat Washers, (6) 6mm Lock Washers and (6) 6mm Hex Nuts, (**Figures 8 & 9**). Do not tighten hardware at this time. **NOTE**, the Running Board is designed to fit close to the vehicle. It may be necessary to loosen the Bracket hardware and tilt the Brackets downward to insert the Running Board between the Brackets and the body.
10. Level and adjust the Running Board and tighten all hardware.
11. Repeat **Steps 2—10** for passenger side Running Board installation.
12. Do periodic inspections to the installation to make sure that all hardware is secure and tight.

**To protect your investment**, wax this product after installing. Regular waxing is recommended to add a protective layer over the finish. Do not use any type of polish or wax that may contain abrasives that could damage the finish.

**For stainless steel:** Aluminum polish may be used to polish small scratches and scuffs on the finish. Mild soap may be used also to clean the Running Board.

**For gloss black finishes:** Mild soap may be used to clean the Running Board.

### Driver Side Installation Pictured

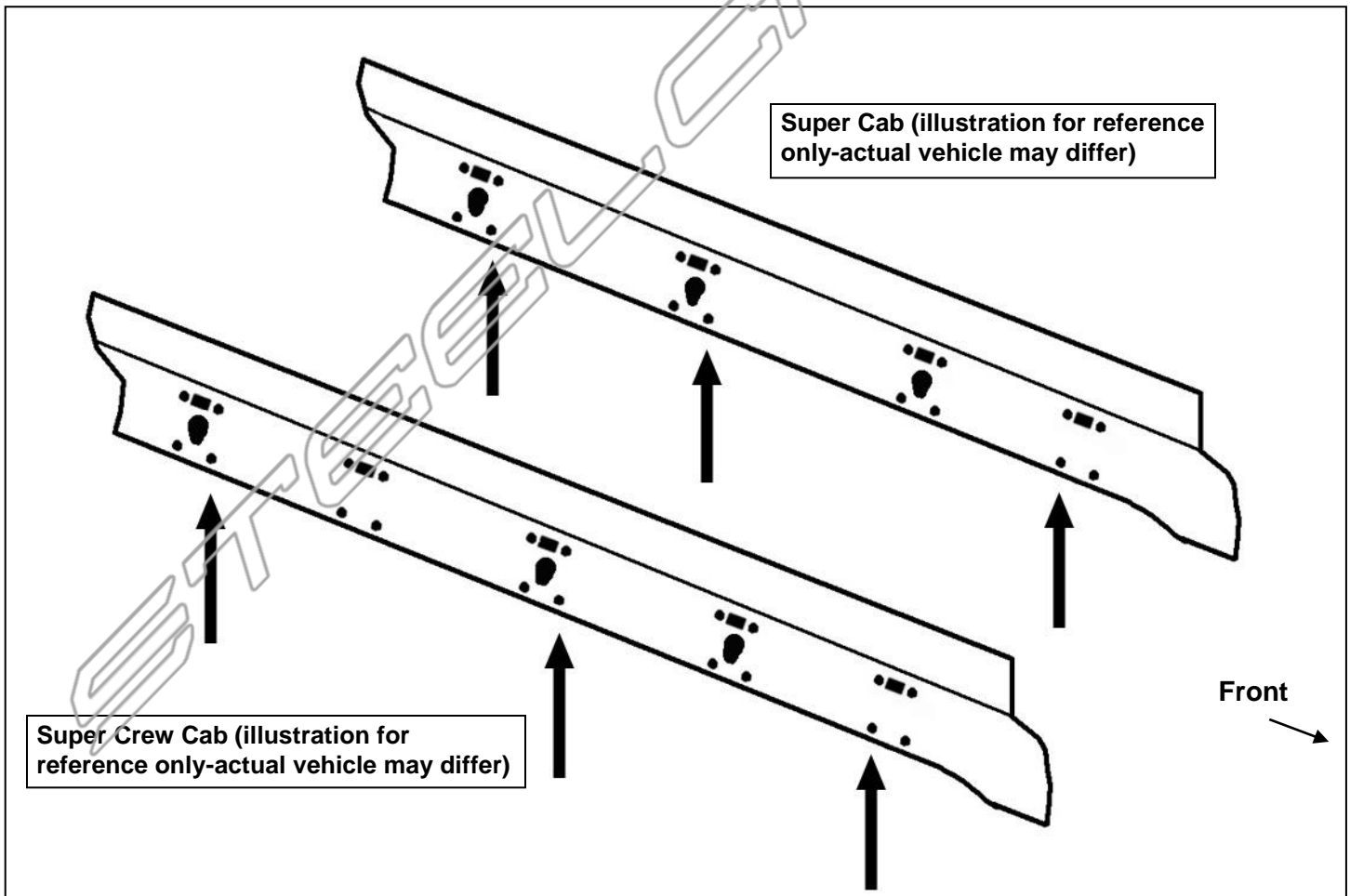

(Fig 1) Driver/left side mounting area illustrated for instruction purposes only

**STX300 RUNNING BOARD**  
**99-15 FORD SUPERDUTY SUPER CAB AND CREW CAB**  
**Driver Side Installation Pictured**

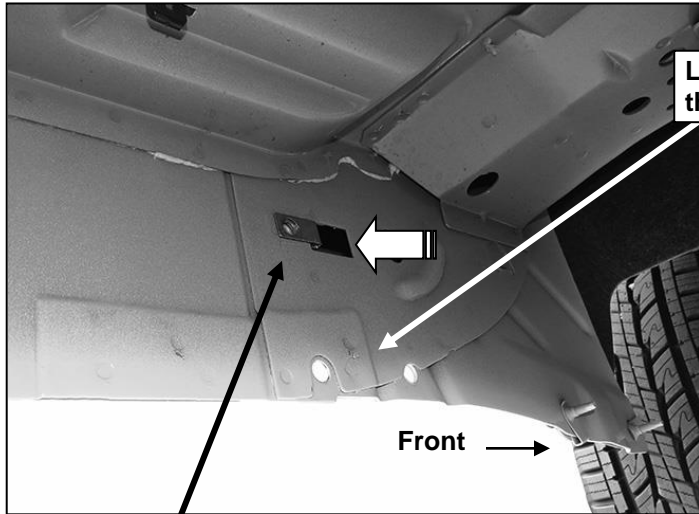

Locate factory holes through pinch weld

**(Fig 2) Slide 8mm Clip Nut into rectangular opening**

- 8mm x 25mm Hex Bolt
  - (2) 8mm Flat Washers
  - 8mm Nylon Lock Nut
- 8mm Clip Nut
  - 8mm x 25mm Hex Bolt
  - 8mm Lock Washer
  - 8mm Flat Washer

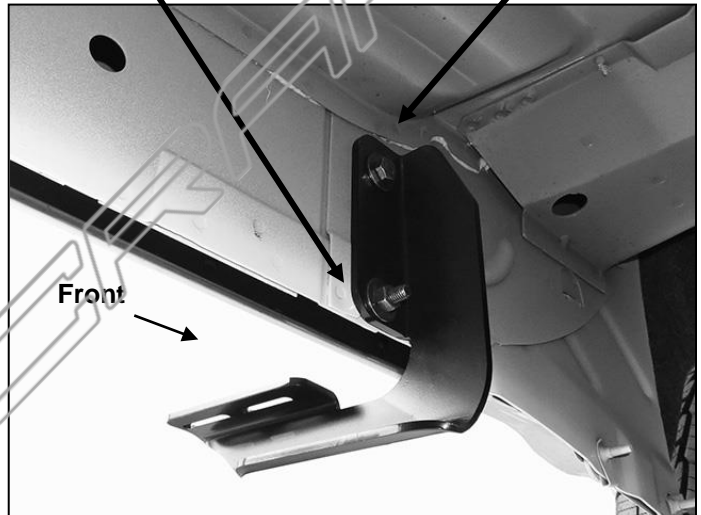

**(Fig 3) Driver/left front mounting Bracket pictured**

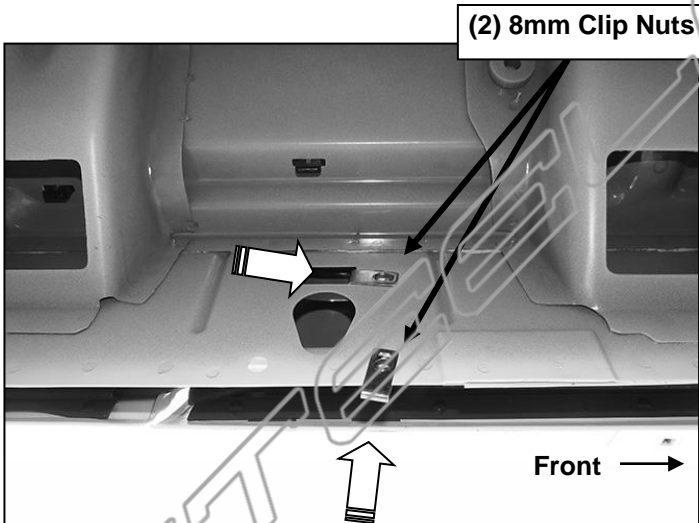

(2) 8mm Clip Nuts

**(Fig 4) Driver/left center mounting location pictured**

- (2) 8mm Clip Nuts
- (2) 8mm x 25mm Hex Bolts
- (2) 8mm Lock Washers
- (2) 8mm Flat Washers

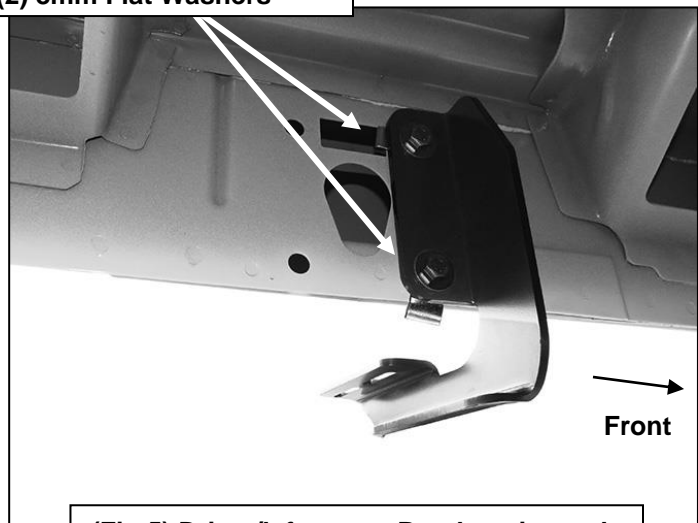

**(Fig 5) Driver/left center Bracket pictured**

**STX300 RUNNING BOARD**  
**99-15 FORD SUPERDUTY SUPER CAB AND CREW CAB**  
**Driver Side Installation Pictured**

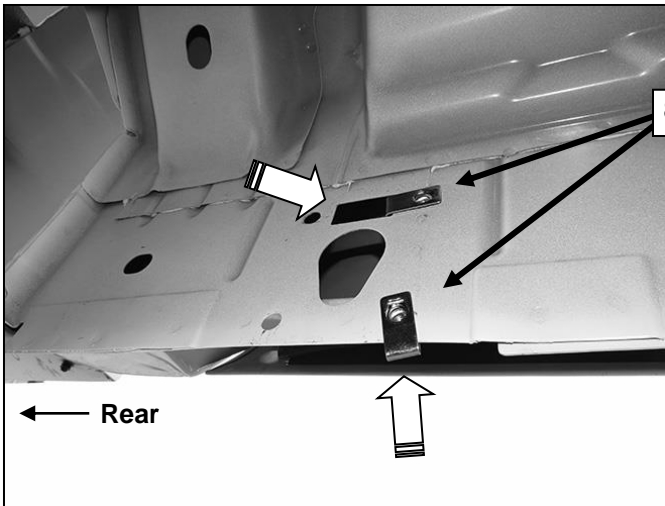

**(Fig 6) Driver/left rear Mounting Bracket location**

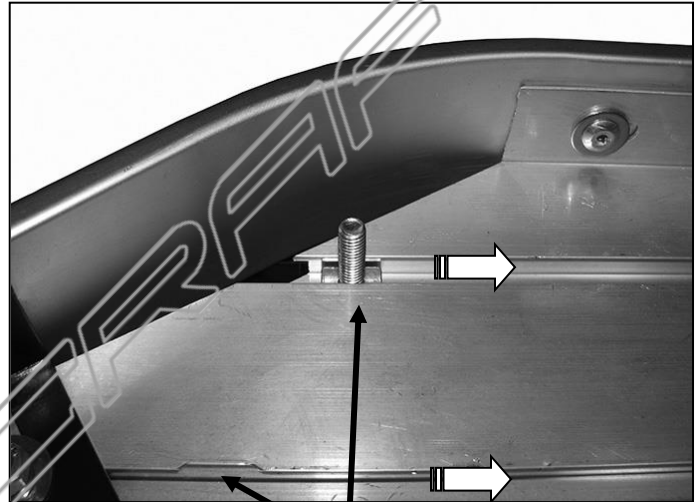

**(Fig 7) Slide 6mm T-Bolts into channels**

- (2) 6mm T-Bolts
- (2) 6mm Flat Washers
- (2) 6mm Lock Washers
- (2) 6mm Hex Nuts

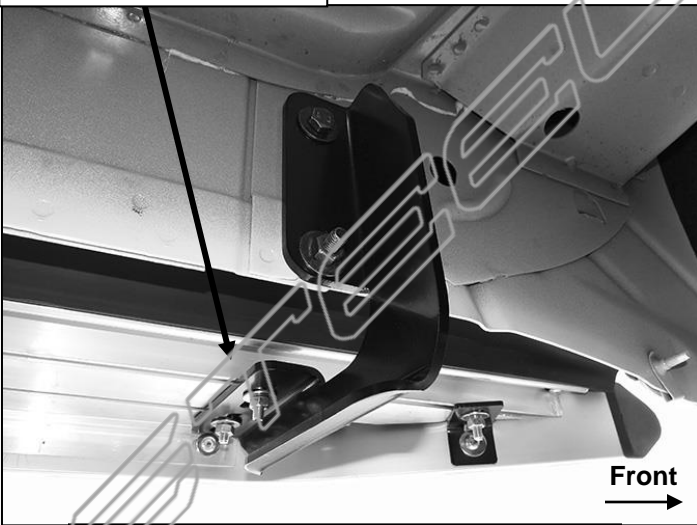

**(Fig 8) Driver/left front Bracket installed**

- (2) 6mm T-Bolts
- (2) 6mm Flat Washers
- (2) 6mm Lock Washers
- (2) 6mm Hex Nuts

- (2) 8mm Clip Nuts
- (2) 8mm x 25mm Hex Bolts
- (2) 8mm Lock Washers
- (2) 8mm Flat Washers

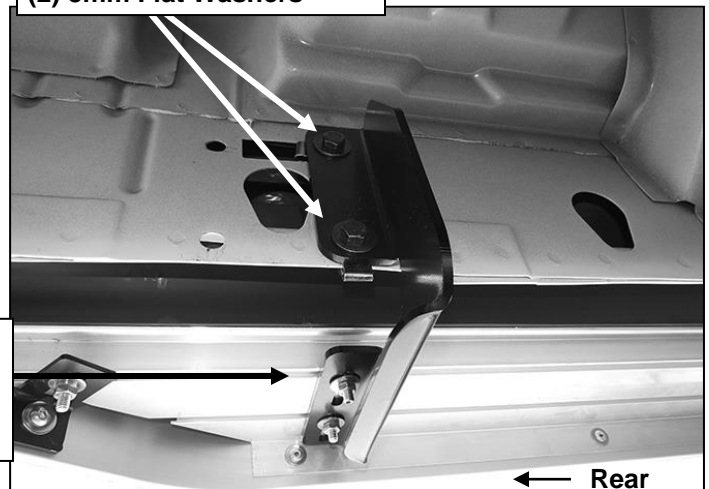

**(Fig 9) Driver/left rear Mounting Bracket installed**