

INSTALLATION INSTRUCTIONS

ELEVATION REAR BUMPER

2015-16 FORD F150

STEELCRAFT

PARTS LIST:

1	Elevation Rear Bumper Assembly	2	Plastic Plugs (license plate mount)
6	12-1.75mm x 50mm Hex Bolts	8	4mm x 10mm Socket Head Screws
12	12mm x 37mm OD x 3mm Flat Washers	1	Wrench
6	12-1.75mm Nylon Lock Nuts	4	Sensor Hole Plugs

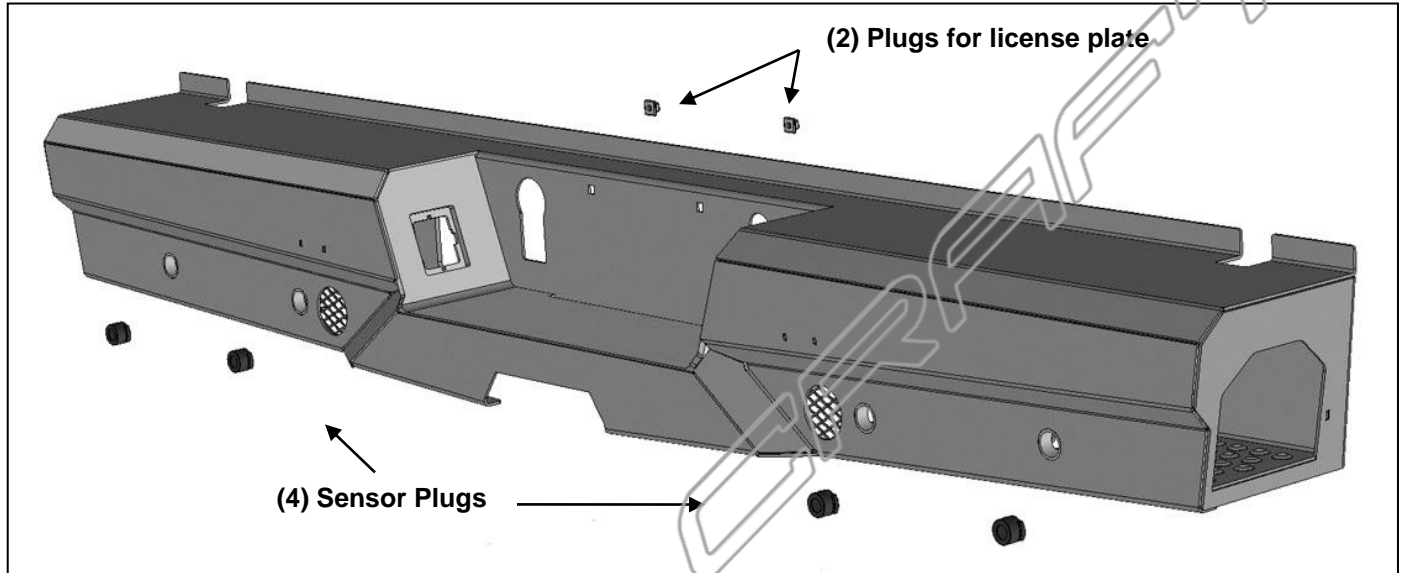

PROCEDURE:

REMOVE CONTENTS FROM BOX. VERIFY ALL PARTS ARE PRESENT. READ INSTRUCTIONS CAREFULLY BEFORE STARTING INSTALLATION. BUMPER IS HEAVY, ASSISTANCE IS HIGHLY RECOMMENDED TO AVOID POSSIBLE INJURY OR DAMAGE TO THE VEHICLE.

IMPORTANT: OEM "MEDIUM DUTY AND HEAVY DUTY" RECEIVER HITCH IS INTEGRATED INTO THE ORIGINAL REAR BUMPER AND CANNOT BE REINSTALLED. INSTALLATION IS DIRECTLY COMPATIBLE WITH OEM "STANDARD" TOW PACKAGE (NO RECEIVER) AND RECOMMENDED "MAX DUTY" HITCH AND MOST AFTERMARKET RECEIVER HITCHES.

1. Remove the license plate and bracket. Unplug and remove the factory license plate lights and move the harness away from the bumper, **(Figure 1)**. Also unplug and remove the trailer/towing plug and wiring harness if equipped, **(Figure 2)**. **NOTE:** Bumper is specifically designed to be compatible with larger 7-wire trailer harness plug.
2. On models with back up sensors, unplug the sensors and move the wiring harness away from the factory bumper. Next, carefully remove the sensors from the bumper.
3. Place blocks or jack stands under the bumper to support it during mounting bolt removal. Once the bumper has been safely supported, remove the factory hardware attaching the bumper to the end of the frame and remove the bumper, **(Figures 3 & 4)**. **WARNING!** Assistance is required to hold the bumper in place during hardware removal to prevent the bumper from falling.

IMPORTANT: On models with OE "HD" tow package, the factory bumper features an integrated receiver hitch, **(Figure 4)**. This receiver hitch cannot be reinstalled with the Elevation Bumper. The Elevation Bumper is compatible with the OE standard tow package, (no receiver hitch-see **Figure 4**), and the OE "MAX DUTY" tow package and most replacement receiver hitches, **(Figure 5)**.

4. With assistance, position the Elevation Bumper up to the end of the frame, **(Figure 6)**. Temporarily support the weight of the Bumper Assembly. **WARNING:** To avoid possible injury or damage to the vehicle, do not proceed until the Bumper is fully and safely supported.
5. Line up the holes in the mounting plates on the Bumper with the mounting flanges on the end of the frame. Attach the Bumper bracket to the frame with the included (6) 12mm x 50mm Hex Bolts, (12) 12mm Flat Washers and (6) 12mm Nylon Lock Nuts, **(Figures 7 & 8)**. Snug but do not fully tighten hardware.
6. Slowly lower the tailgate and check for clearance. Level and adjust the bumper as required and fully tighten all hardware to 65-70ft-lbs.
7. Use the included (2) push-in plastic plugs to attach the license plate to the Bumper Assembly, **(Figure 9)**.
8. Reinstall the factory license plate lights and 7-wire trailer plug, (if equipped). Reattach the factory wire harness.
9. **Models with bumper mounted sensors:**
 - a. Remove the rubber plugs from the sockets in the bumper assembly, **(Figure 10)**. Push the sensor in from the back of the bumper. Secure each sensor to the socket with (2) 4mm x 10mm Button Head Screws, **(Figure 11)**. **IMPORTANT:** Sensors fit snug in sockets. The 4mm Screws are used to apply slight pressure to lock the sensors in place. Tighten both screws evenly until they touch the sensor body only. Do not overtighten screws or damage to sensors will result.
 - b. Reattach the factory wiring harness to sensors.
10. Secure the wire harness to the vehicle and bumper.
11. Do periodic inspections to the installation to make sure that all hardware is secure and tight.

To protect your investment, wax this product after installing. Regular waxing is recommended to add a protective layer over the finish. Do not use any type of polish or wax that may contain abrasives that could damage the finish. Mild soap may be used to clean the Rear Bumper assembly.

Passenger/right Side Installation Pictured

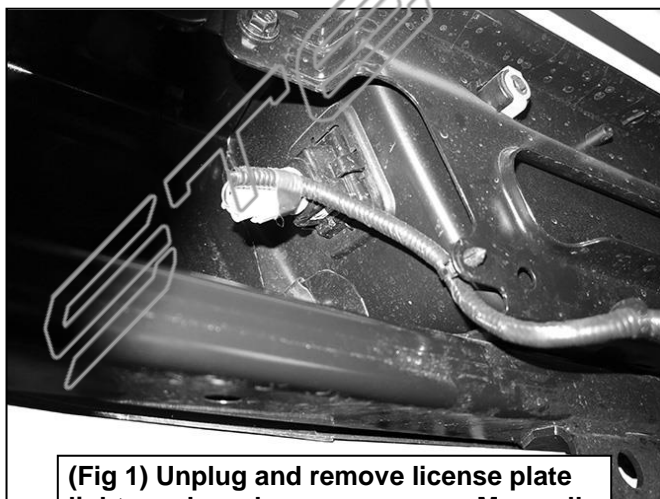

(Fig 1) Unplug and remove license plate lights and any bumper sensors. Move all wire harnesses away from bumper



(Fig 2) Unplug and remove 7-wire trailer plug

Passenger/right Side Installation Pictured

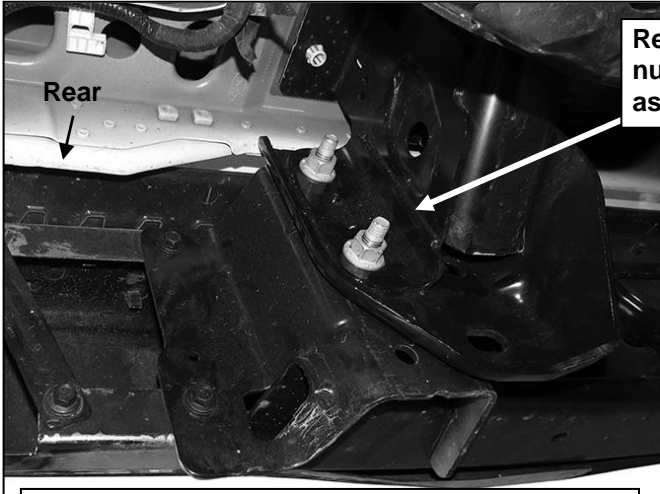

Remove the factory hex nuts attaching bumper assembly to frame

(Fig 3) Remove the factory hex nuts attaching bumper assembly to frame. STD tow package model pictured (no receiver hitch)

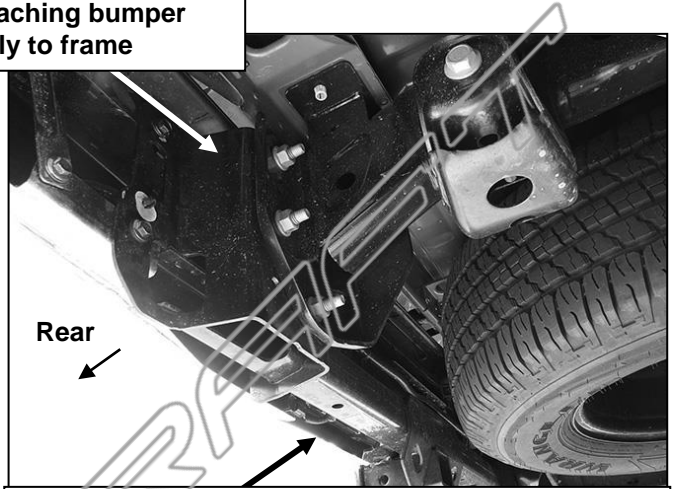

(Fig 4) Note bumper with integrated receiver hitch. Hitch cannot be reinstalled with Elevation Bumper

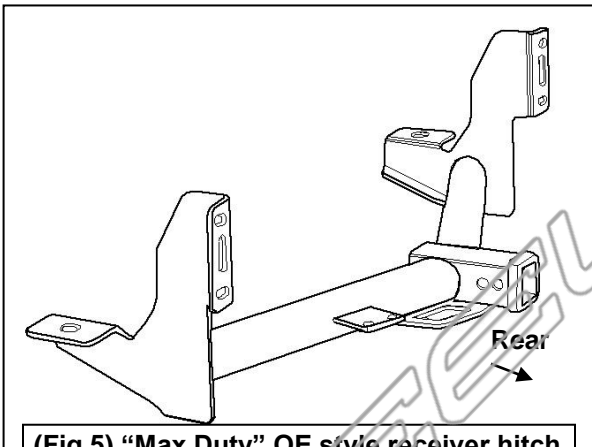

(Fig 5) "Max Duty" OE style receiver hitch

IMPORTANT: Only "Max Duty" OE style receiver hitch is compatible with Elevation Bumper. Note hitch attaches in front of bumper brackets and does not attach to factory bumper

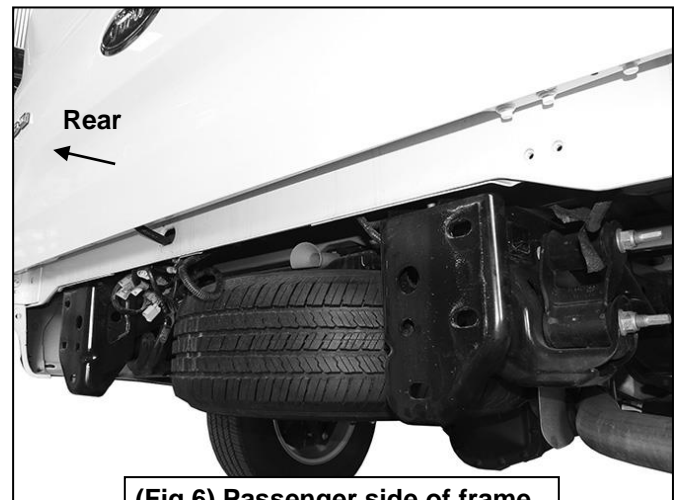

(Fig 6) Passenger side of frame

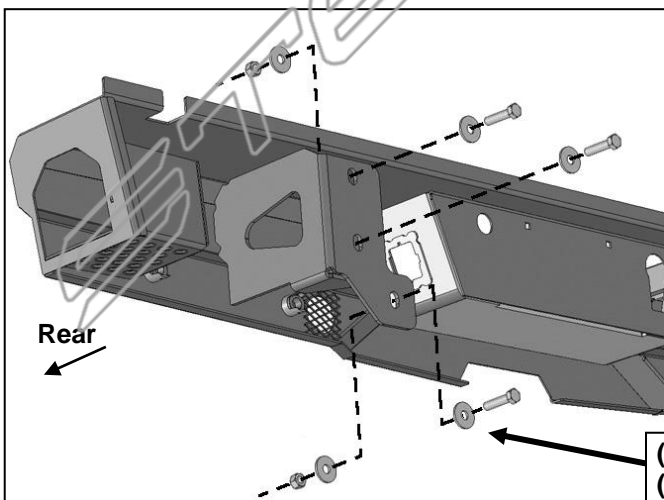

(Fig 7) Attach Bumper to end of frame

- (3) 12mm x 50mm Hex Bolts
- (6) 12mm Flat Washers
- (3) 12mm Nylon Lock Nuts

WARNING! To avoid injury or damage to the vehicle, do not remove bumper bolts unless the bumper is properly supported on blocks and/or stands or the bumper may fall.

Passenger/right Side Installation Pictured

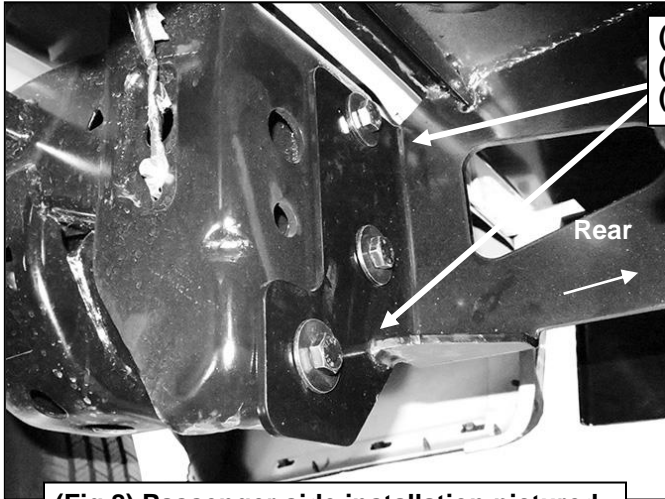

- (3) 12mm x 50mm Hex Bolts
- (6) 12mm Flat Washers
- (3) 12mm Nylon Lock Nuts

(Fig 8) Passenger side installation pictured

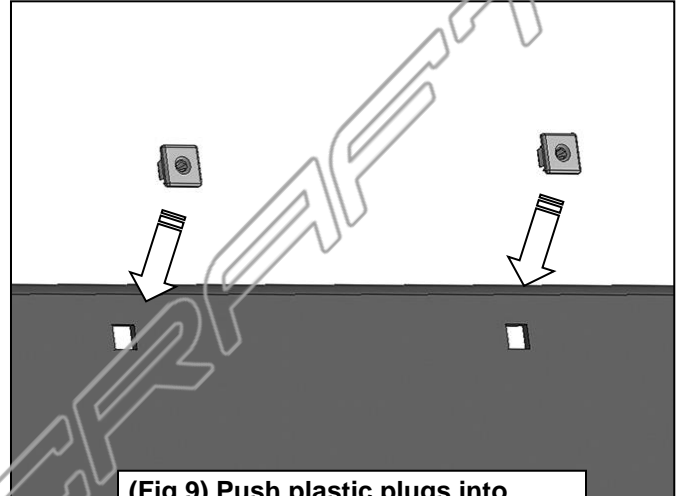

(Fig 9) Push plastic plugs into holes in Bumper for license plate

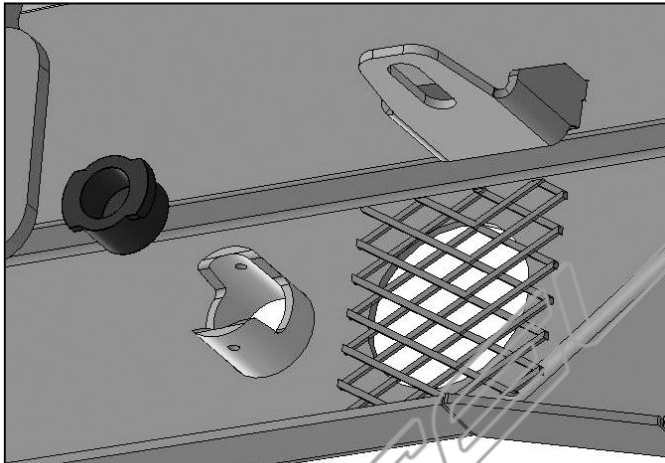

(Fig 10) Remove plugs from holes in bumper. Insert sensor (if equipped) into socket on back of bumper.

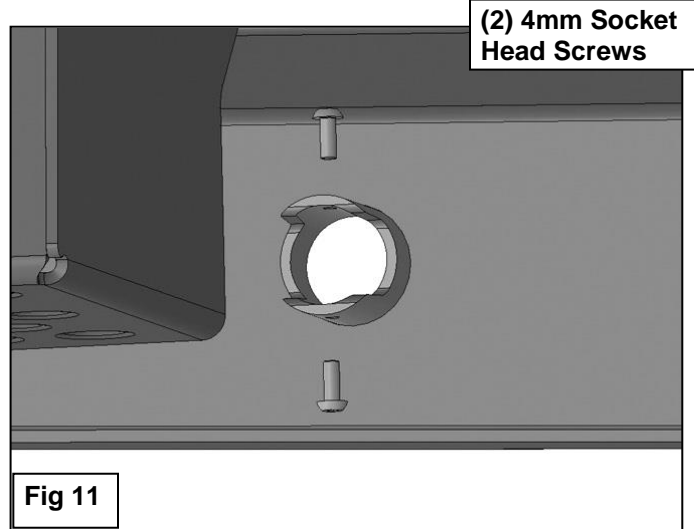

(2) 4mm Socket Head Screws

Fig 11



Complete Installation

IMPORTANT: Sensors fit snug in sockets. The 4mm Screws are used to apply slight pressure to lock the sensors in place. Tighten both screws evenly until they touch the sensor body only. Do not overtighten screws or damage to sensors will result