

(EXCLUDES 15-25-3500 SPORT AND LARAMIE MODELS)

PARTS LIST:

Qty	Description	Qty	Description
1	Bull Bar	10	12mm Lock Washers
2	Frame Mounting Brackets	20	12mm x 37mm OD x 3mm Flat Washers
2	12-1.75mm x 100mm Hex Bolts	10	12-1.75mm Hex Nuts
8	12-1.75mm x 30mm Hex Bolts		

PROCEDURE:

REMOVE CONTENTS FROM BOX. VERIFY ALL PARTS ARE PRESENT. READ INSTRUCTIONS CAREFULLY BEFORE STARTING INSTALLATION. CUTTING IS REQUIRED. ASSISTANCE IS RECOMMENDED. It may be necessary to remove/relocate front license plate and license plate bracket. It is not required, but strongly recommended. If local/state law requires a front license plate, a license plate relocation kit is available.

1. Starting under the passenger side of the front bumper, hold (1) Frame Mounting Bracket in approximate position to determine the mounting location. Locate the (2) holes in the frame below the body mount brackets. **NOTE:** Remove factory tow hook bolts, (if supplied), and save for re-installation. On some models, the hex nuts inside the frame rail may also need to be removed.
2. Bolt the Mounting Bracket into position on the passenger side against the side of the frame channel with (2) 12mm x 30mm Hex Bolts, (4) 12mm Flat Washers, (2) 12mm Lock Washers and (2) 12mm Hex Nuts in the top (2) mounting holes or use the factory hardware removed in **Step 1, (Figure 1)**.
 - a. **1998-newer w/o tow hooks:** Insert (1) 12mm x 100mm Hex Bolt, (2) 12mm Flat Washers, (1) 12mm Lock Washer and (1) 12mm Hex Nut in the center mounting hole and through the frame channel. Snug but do not tighten hardware at this time. Repeat **Steps 1 & 2** for driver side Mounting Bracket installation.
3. Remove the air dam from the bottom of the bumper and move it to a clean stable work area. Pay close attention to the type and location of all factory hardware for reinstallation.
4. With help, position the Bull Bar up to the inside or outside of the Mounting Brackets depending on model year, **(Figures 2A & 2B)**. Use the included (4) 12mm x 30mm Hex Bolts, (4) 12mm Lock Washers, (8) 12mm Flat Washers and (4) 12mm Hex Nuts to temporarily attach the Bull Bar to the holes in the Mounting Brackets, **(Figure 1)**. Snug but do not tighten hardware.
5. Stand back from the vehicle and check to see that the Bull Bar is centered and level on the vehicle and adjust as necessary. **IMPORTANT:** Once properly aligned, tighten only the hardware securing the Mounting Brackets to the truck. Do not tighten the hardware on the Bull Bar at this time.
6. Measure from the bottom of the factory bumper to the top of the lower tube on the Bull Bar, **(Figure 3)**.
7. Remove the Bull Bar.
8. Reinstall the air dam. Hold the Bull Bar up to the Brackets and install the (2) rear bolts only. Snug but do not tighten. Rotate the Bull Bar up to the air dam. Mark the location of the Bull Bar onto the bottom of the air dam, **(Figure 3)**. Cover the air dam with masking tape. Trace a horizontal line at the measurement recorded in **Step 5**. Draw a parallel line, 1-1/2 below the first to mark the center of the hole for the Bull Bar. Cut (2) approximately 3-1/8" holes in the air dam to clear the Bull Bar. **NOTE:** Due to different factory designs for air dams and front bumpers, exact location to cut for clearance must be determined by the installer. To maintain the integrity of the air dam, do not cut the holes any larger than absolutely necessary. It is recommended to make several small cuts and check the fit often for a clean installation.
9. Reinstall the Bull Bar as instructed in **Step 4**. Level and adjust the Bull Bar and tighten all hardware.
10. Do periodic inspections to the installation to make sure that all hardware is secure and tight.

To protect your investment, wax this product after installing. Regular waxing is recommended to add a protective layer over the finish. Do not use any type of polish or wax that may contain abrasives that could damage the finish.

For stainless steel: Aluminum polish may be used to polish small scratches and scuffs on the finish. Mild soap may be used also to clean the Bull Bar.

For gloss black finishes: Mild soap may be used to clean the Bull Bar.

BULL BAR
94-01 DODGE RAM 1500
94-02 DODGE RAM 25-3500
(EXCLUDES 15-25-3500 SPORT AND LARAMIE MODELS)

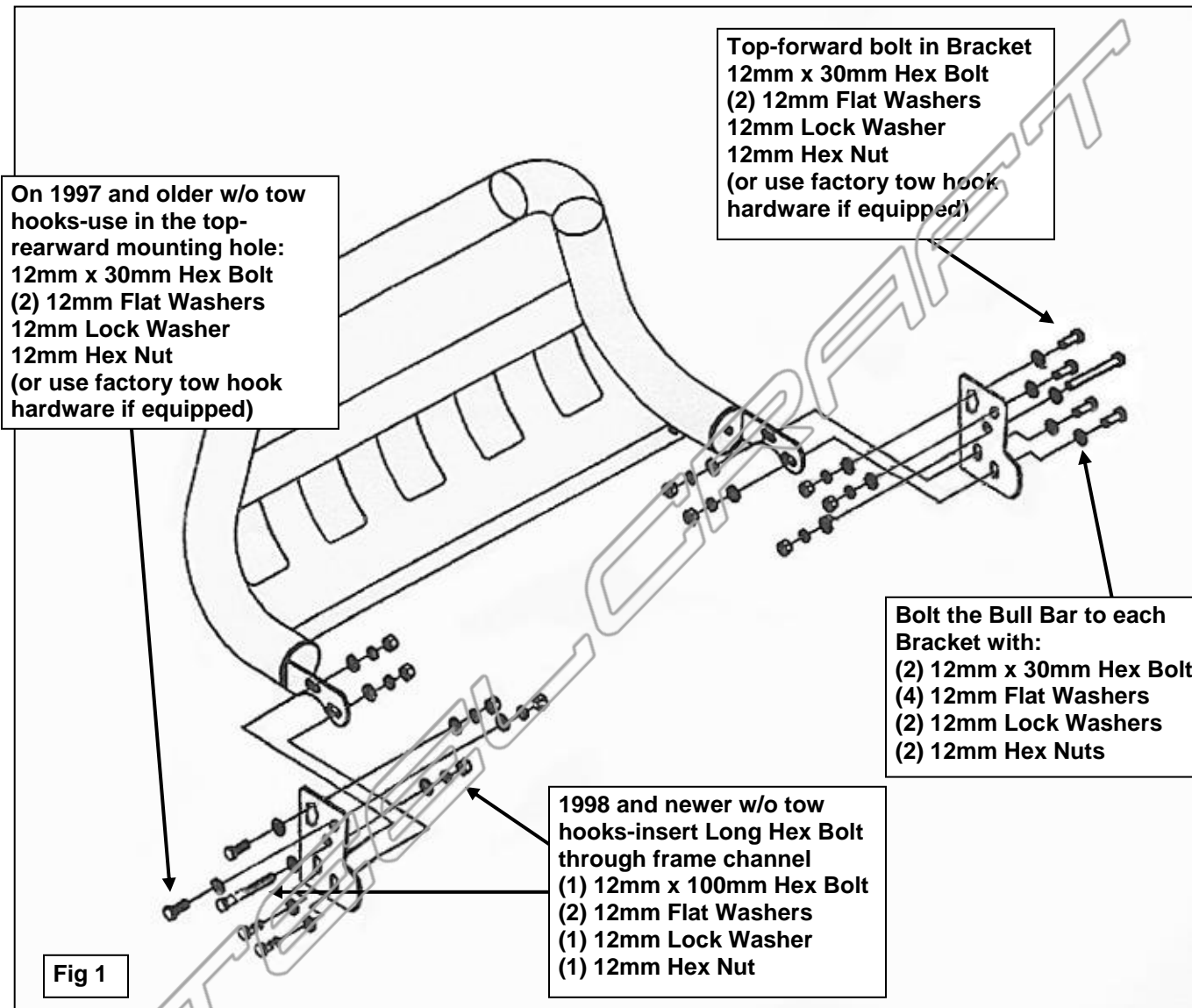

Depending on model year, Bull Bar may line up with the inside or outside of Mounting Brackets-passenger side installation pictured

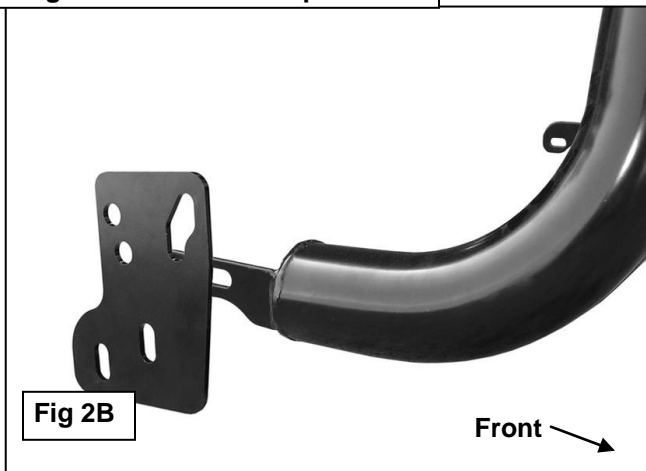
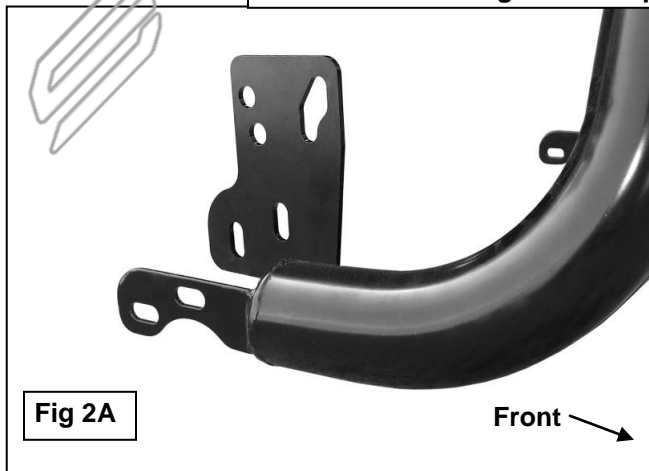

BULL BAR
94-01 DODGE RAM 1500
94-02 DODGE RAM 25-3500
(EXCLUDES 15-25-3500 SPORT AND LARAMIE MODELS)

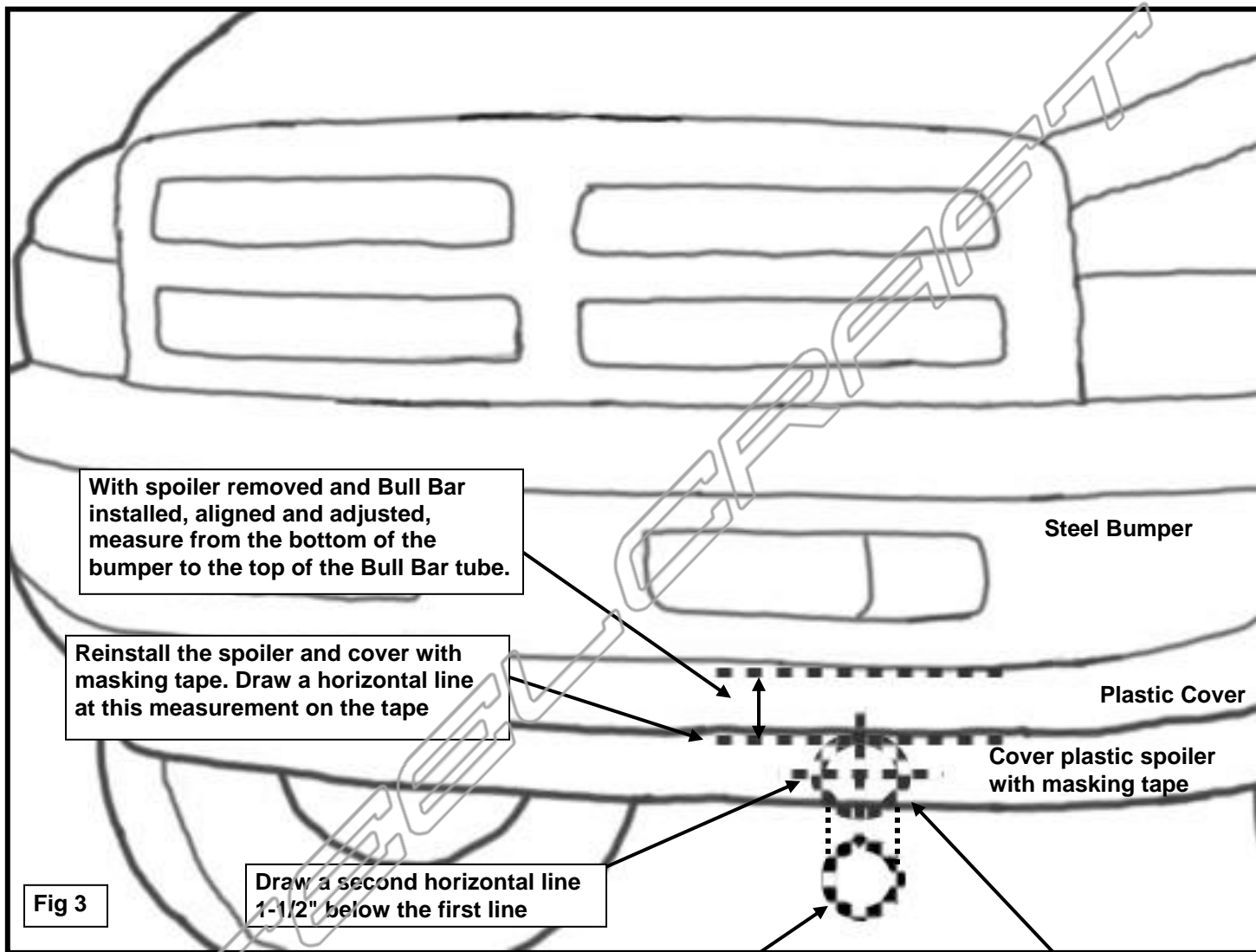

Illustrations, diagrams and measurements provided for example only. It is the installer's responsibility to determine exact cuts/modifications to the vehicle required for proper installation.