

**MODULAR REAR BUMPER
07-16 JEEP J/K WRANGLER**

PARTS LIST:

1	Bumper Center Section	4	12mm Lock Washers
1	Driver/Left Wing	4	10-1.5mm x 35mm Button Head Bolts
1	Passenger/Right Wing	4	10-1.5mm x 35mm Hex Bolts
1	Driver/Left Support Bracket	8	10-1.5mm x 30mm Hex Bolts
1	Passenger/Right Support Bracket	28	10mm x 20mm OD x 2mm Flat Washers
2	12mm Double Nut Plates	16	10mm Lock Washers
4	12-1.75mm x 35mm Hex Bolts	12	10mm Hex Nuts
4	12mm x 24mm OD x 2.5mm Flat Washers	1	Wrench

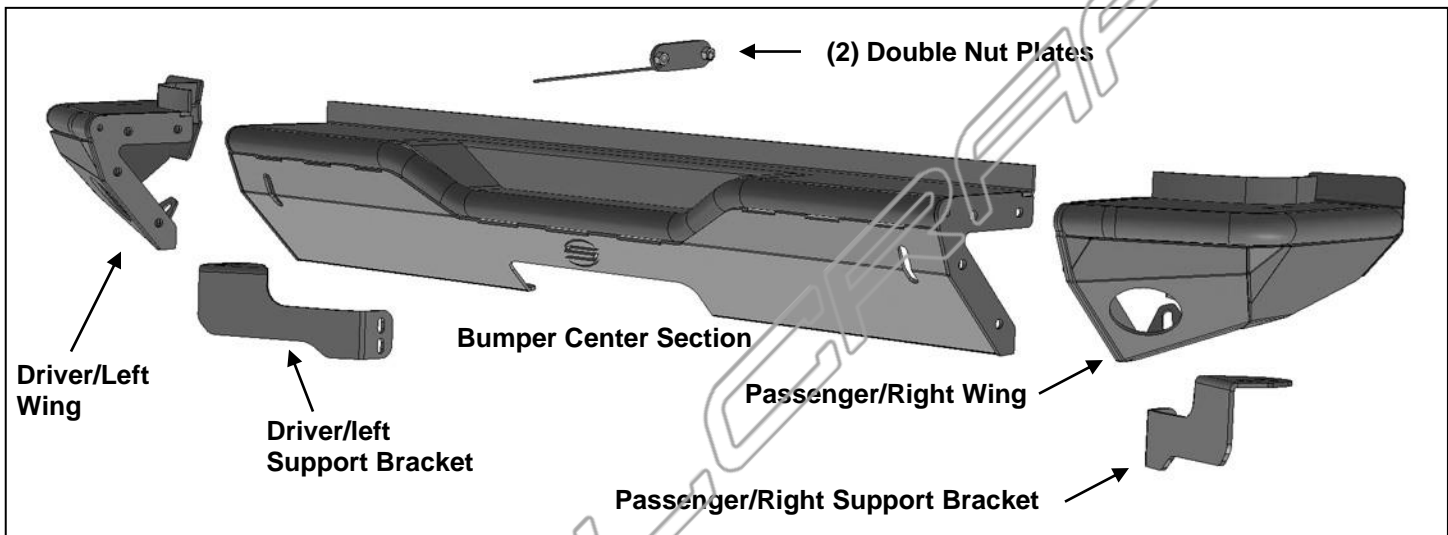

REMOVE CONTENTS FROM BOX. VERIFY ALL PARTS ARE PRESENT. READ INSTRUCTIONS CAREFULLY BEFORE STARTING INSTALLATION. ASSISTANCE IS RECOMMENDED. WARNING: ALLOW TIME FOR THE MUFFLER TO COMPLETELY COOL BEFORE REMOVING REAR BUMPER OR INSTALLING REAR BUMPER BRACKETS.

- Starting on the driver/left side, locate and remove the hardware attaching the support bracket to the side of the frame, **(Figure 1)**. Repeat to remove the passenger side support bracket hardware. Next, locate and remove the two "Z" brackets attaching the center section of the bumper to the back of the frame cross-member, **(Figure 2)**. With assistance, carefully remove the bumper assembly.
- Next, remove the tow hook assembly from the frame if equipped, **(Figure 3)**.
- Carefully unwrap the Modular Bumper Center Section and End Wings. Select the driver/left Wing. Attach the Wing to the left side of the Center Section with (4) 10mm x 30mm Hex Bolts, (8) 10mm Flat Washers, (4) 10mm Lock Washers and (4) 10mm Hex Nuts, **(Figure 4)**. Line up the Wing with the Center Section and fully tighten hardware. Repeat this Step to attach the passenger side Wing to the Center Section. **NOTE:** Fully assembled Bumper is heavy; Wings can also be installed after Center Section has been installed on vehicle but Wing hardware is slightly difficult to access.
- Select the 12mm Double Nut Plate, **(Figure 5)**. Insert the Nut Plate into the open end of the frame. With assistance, carefully position the mounting tabs on the Bumper assembly up to the outside of the frame. Use the long wire handle on the Nut Plates to position the nut plates in line with the factory holes in the side of the frame. Attach the driver side mounting tab on the Bumper to the Nut Plate with (2) 12mm x 35mm Hex Bolts, (2) 12mm Lock Washers and (2) 12mm Flat Washers, **(Figure 5)**. Snug but do not fully tighten hardware. Repeat this Step to attach the passenger side of the Bumper to the Double Nut Plate. **NOTE:** Wire handle on Nut Plate can be bent down or removed once bumper assembly is fully installed.
- Each Bumper Wing features a mounting tab for installation of aftermarket 3" round light, (not included). Follow light manufacturer's instructions to install lights at this time or proceed to **Step 6**. **NOTE:** Depending on overall size of lights, Support Brackets installed in **Step 6** may need to be removed before light installation.

**MODULAR REAR BUMPER
07-16 JEEP J/K WRANGLER**

6. Select the driver/left side Support Bracket. Attach the Support Bracket to the bottom side of the Wing with the included (2) 10mm x 35mm Button Head Bolts, (4) 10mm Flat Washers, (2) 10mm Lock Washers and (2) 10mm Hex Nuts, **(Figure 6)**. Do not tighten hardware. Line up the remaining end of the Support Bracket with the (2) threaded holes in the side of the frame. Attach the Bracket to the frame with (2) 10mm x 35mm Hex Bolts, (2) 10mm Lock Washers and (2) 10mm Flat Washers, **(Figure 7)**. Do not tighten hardware at this time. Repeat this Step to install the passenger side Support Bracket.
7. Level and adjust the Rear Bumper Assembly and tighten all hardware at this time.
8. Do periodic inspections to the installation to make sure that all hardware is secure and tight.

To protect your investment, wax this product after installing. Regular waxing is recommended to add a protective layer over the finish. Do not use any type of polish or wax that may contain abrasives that could damage the finish. Mild soap may be used to clean the Bumper assembly.

Driver Side Installation Pictured

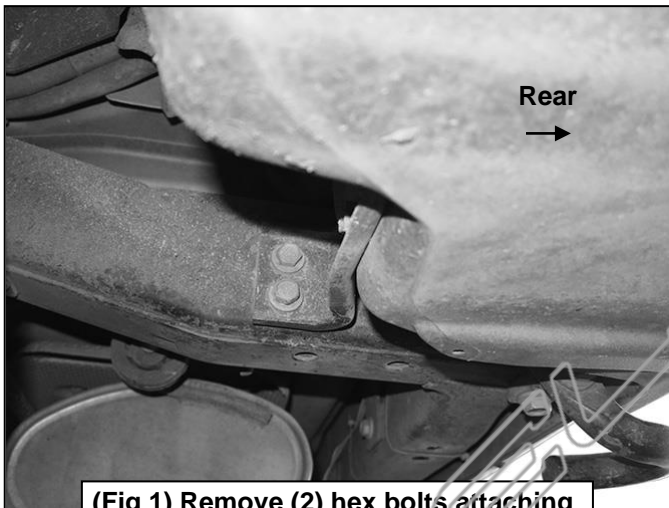

(Fig 1) Remove (2) hex bolts attaching support bracket to side of frame

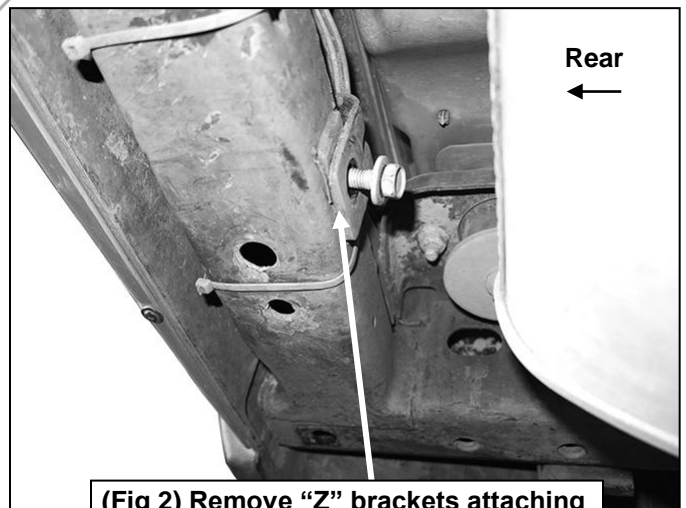

(Fig 2) Remove "Z" brackets attaching bumper to back of cross member

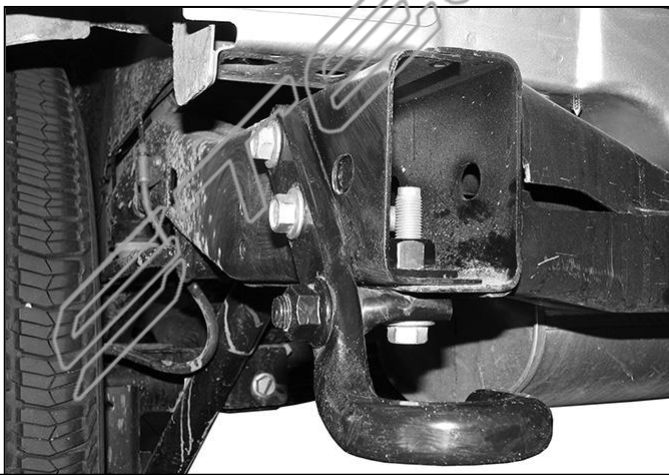

(Fig 3) Remove tow hook and hardware (if equipped)

Driver Side Installation Pictured

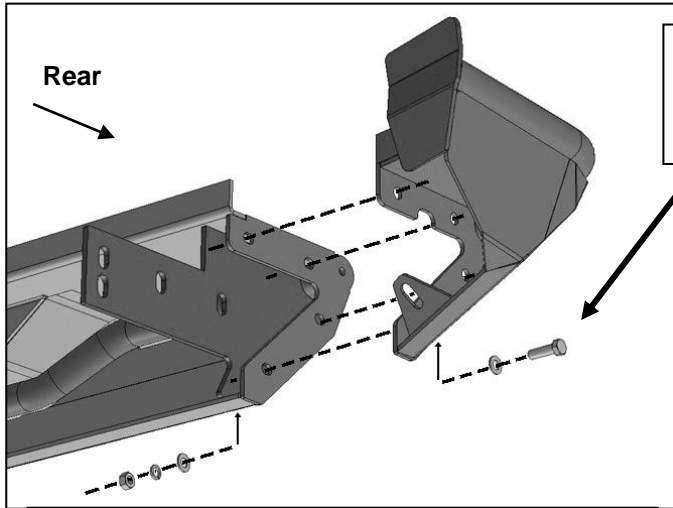

- (4) 10mm x 30mm Hex Bolts
- (8) 10mm Flat Washers
- (4) 10mm Lock Washers
- (4) 10mm Hex Nuts

Insert Double Nut Plate into open end of frame

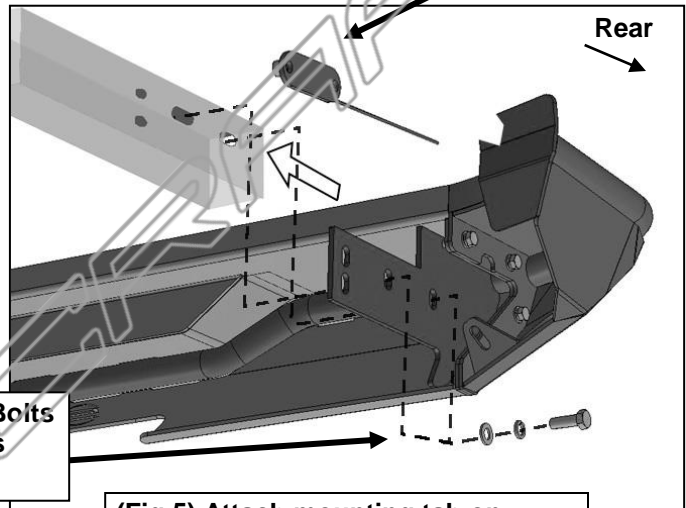

(Fig 4) Attach driver side Wing to center section

(Fig 5) Attach mounting tab on Bumper Center Section to Nut Plate

- (2) 10mm x 35mm Button Head Bolts
- (4) 10mm Flat Washers
- (2) 10mm Lock Washers
- (2) 10mm Hex Nuts

- (2) 12mm x 35mm Hex Bolts
- (2) 12mm Lock Washers
- (2) 12mm Flat Washers

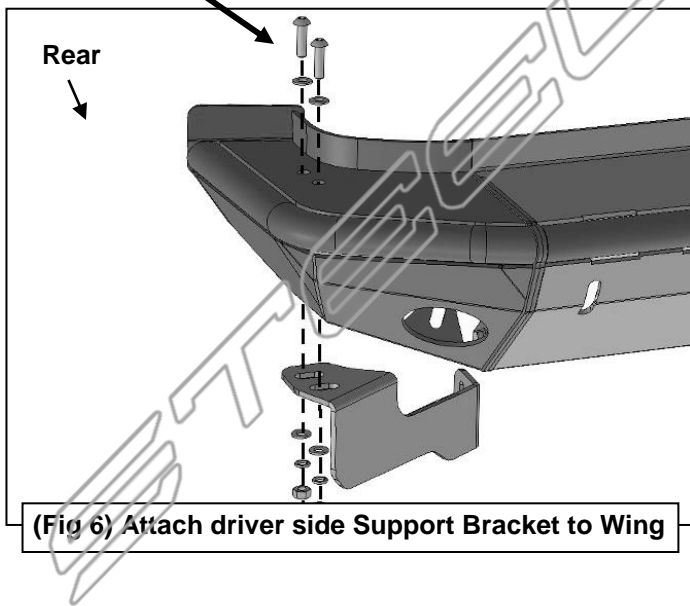

(Fig 6) Attach driver side Support Bracket to Wing

- (2) 10mm x 35mm Hex Bolts
- (2) 10mm Lock Washers
- (2) 10mm Flat Washers

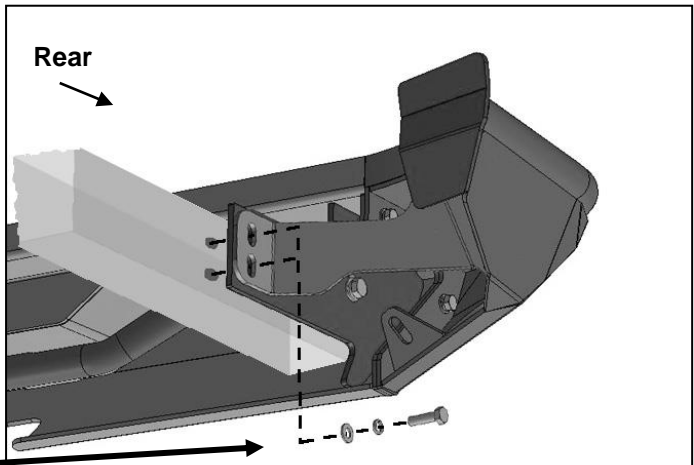

(Fig 7) Attach Support Bracket to side of frame