

INSTALLATION INSTRUCTIONS

**EVO3 RUNNING BOARD
2015 FORD F-150 SUPER CAB**

STEELCRAFT

PARTS LIST:

1	Driver/left Running Board	12	8mm x 24mm x 2mm Flat Washers
1	Passenger/right Running Board	12	8mm Nylon Lock Nuts
		12	8mm Plastic Washers

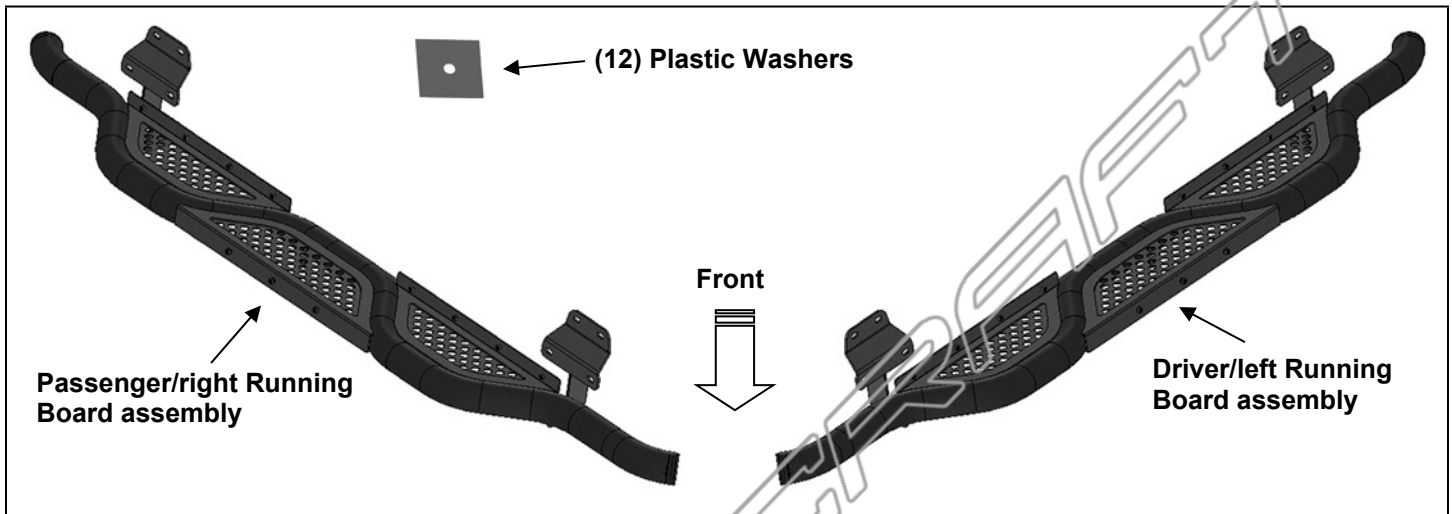

PROCEDURE:

- REMOVE CONTENTS FROM BOX. VERIFY ALL PARTS ARE PRESENT. READ INSTRUCTIONS CAREFULLY BEFORE STARTING INSTALLATION. ASSISTANCE IS RECOMMENDED.**
- Starting on the driver side of the vehicle, locate the front factory running board mounting location along the inner side of the body, **(Figure 1)**.
- Slide (1) Plastic Washer over each factory mounting stud in the body panel, **(Figures 2 & 3)**. **IMPORTANT:** The Plastic Washers are designed to prevent corrosion between the aluminum body panel and the steel mounting brackets. **Do not install the Brackets without the Plastic Washers.**
- Move along the body panel to the rear mounting location toward the back of the cab. Repeat **Step 3** to install the (3) Plastic Retainers.
- Select the driver side Running Board. **NOTE:** The left and right Running Boards look similar. The rear brackets are notched on the back to help identify the front or rear of the Running Board, **(Figure 4)**.
- With assistance, line up the Brackets on the Running Board with the factory mounting studs. Attach the Brackets to the (6) studs with the included (6) 8mm Flat Washers and (6) 8mm Nylon Lock Nuts, **(Figure 5)**.
- Level and adjust the Running Board as desired and tighten all 8mm hardware to 16-18ft-lbs.
- Repeat **Steps 2—7** for the passenger side Running Board installation.
- Do periodic inspections to the installation to make sure that all hardware is secure and tight.

To protect your investment, wax this product after installing. Regular waxing is recommended to add a protective layer over the finish. Do not use any type of polish or wax that may contain abrasives that could damage the finish.

For powder coated finishes: Mild soap may be used to clean the Running Board.

Driver/left Side Installation Pictured

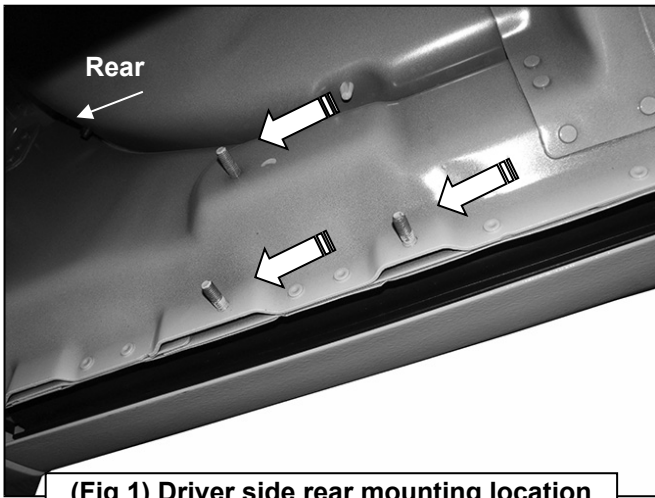

(Fig 1) Driver side rear mounting location

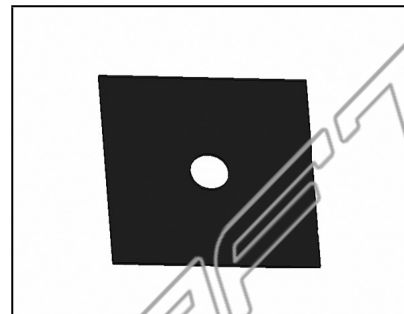

(Fig 2) Plastic Insulation Washer

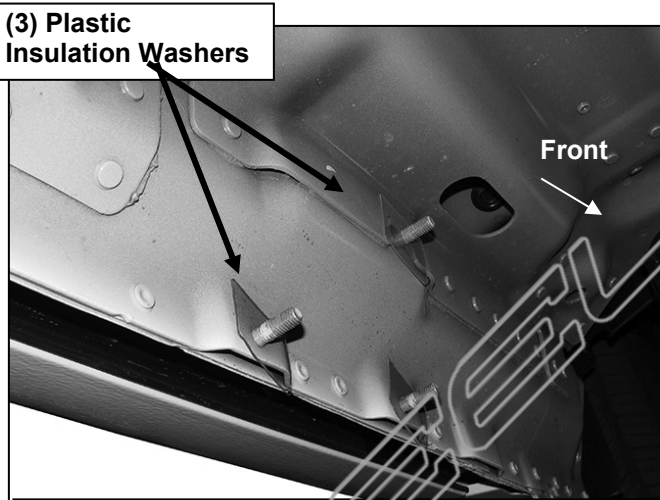

(3) Plastic Insulation Washers

(Fig 3) Thread Plastic Washers onto all mounting studs. Driver side front location pictured

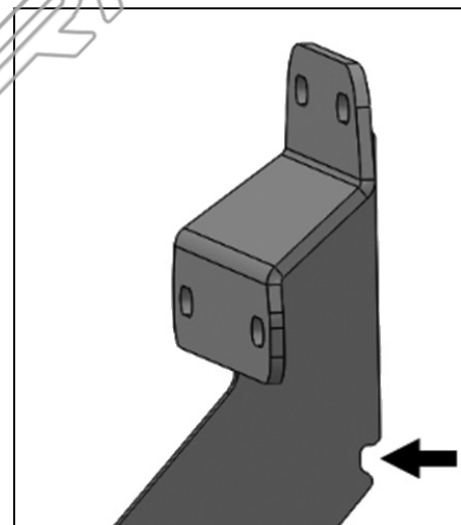

(Fig 4) NOTE: Locate notch in rear brackets to properly determine front and rear of Running Board

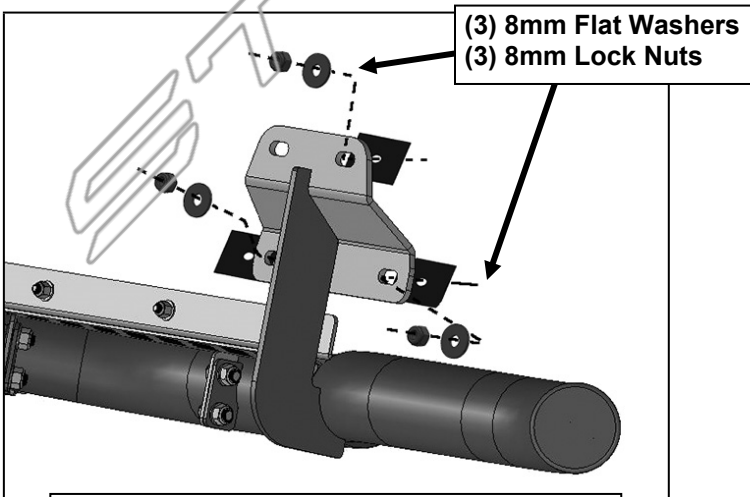

**(3) 8mm Flat Washers
(3) 8mm Lock Nuts**

(Fig 5) Driver side front location illustrated



Complete Installation