

PARTS LIST:

1	Driver/left Running Board Assembly	6	12mm Plastic Retainers
1	Passenger/right Running Board Assembly	6	10-1.5mm x 35mm Hex Bolts
3	Driver/left Support Brackets	6	10mm x 27mm OD x 3mm Flat Washers
3	Passenger/right Support Brackets	6	10mm Lock Washers
6	12mm x 35mm Bolt x 10mm Nut Plates	12	8-1.25mm x 25mm Hex Bolt
6	12mm x 32mm OD x 3mm Flat Washers	24	8mm x 24mm x 2mm flat washer
6	12mm Lock Washers	12	8-1.25mm Hex Nylon Lock Nuts
6	12mm Hex Nuts		

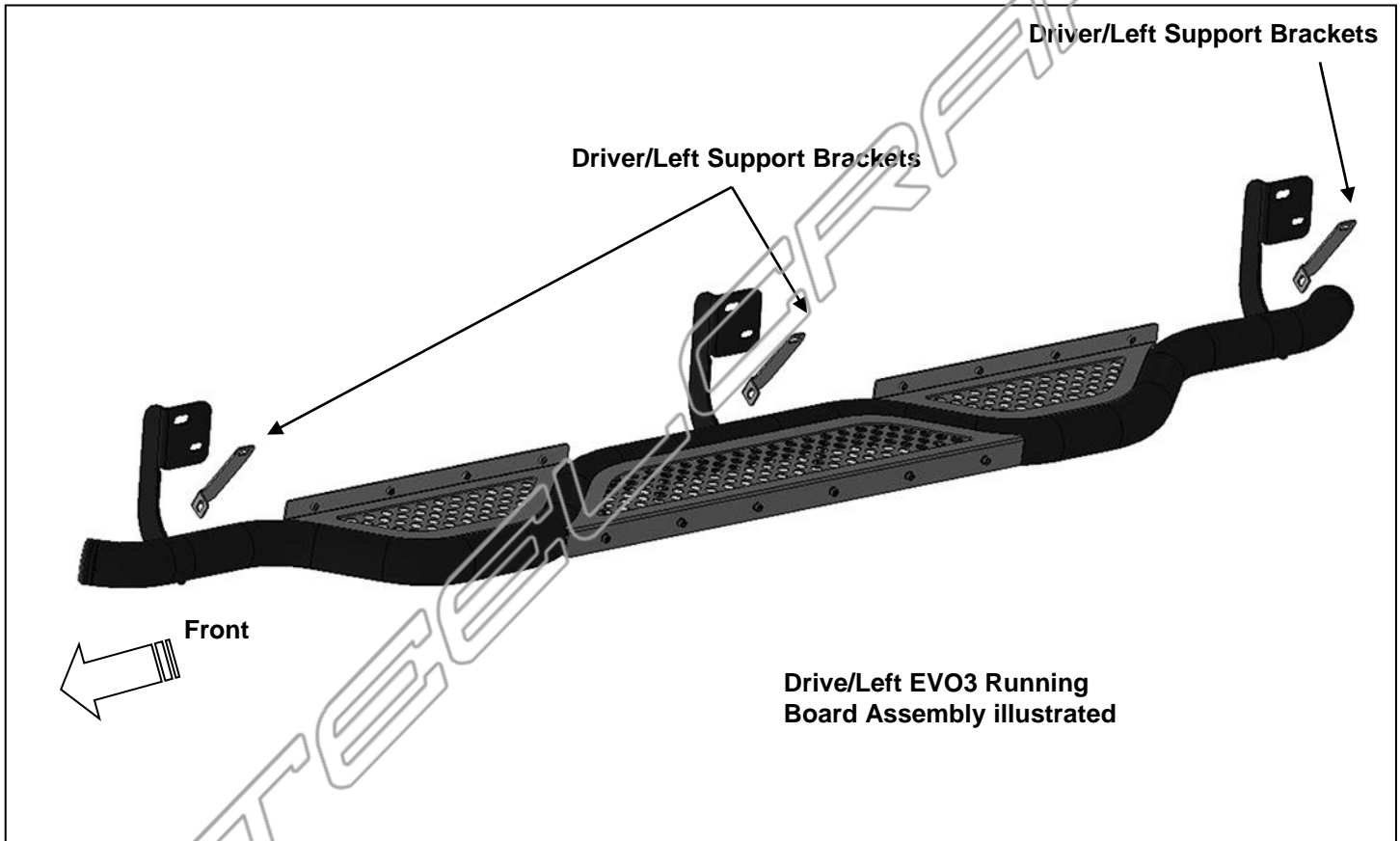

PROCEDURE:

REMOVE CONTENTS FROM BOX. VERIFY ALL PARTS ARE PRESENT. READ INSTRUCTIONS CAREFULLY BEFORE STARTING INSTALLATION. DRILLING IS REQUIRED ON 2009-12 1500, 2010-12 25-3500 MODELS. ASSISTANCE IS RECOMMENDED.

1. Starting at the driver side-front of the vehicle, remove the sealing tape covering the factory holes on the side of the inner panel, **(Figure 1)**. Partially thread (1) 12mm Plastic Retainer onto the threaded end of (1) 12mm Bolt and Nut Plate, **(Figure 2)**. Insert the Bolt and Nut Plate into the factory oval hole. Continue to thread the Plastic Retainer down the Bolt and Nut Plate until it is flush against the sheet metal, **(Figure 3)**. **NOTE:** When properly installed, the Plastic Retainer is designed to prevent the Bolt and Nut Plate from falling into the body panel during Running Board installation.
2. Repeat **Step 1** to install the 12mm Bolt and Nut Plate in the center and rear mounting locations, **(Figures 4 & 5)**.

EVO3 RUNNING BOARD
09-14 DODGE RAM 15-3500 CREW CAB

3. Select the driver/left Running Board. With assistance, hold the Running Board up in position over the (3) Bolt and Nut Plates. Slide the top hole in the Brackets over the Bolt Plate. Attach the Brackets to the Bolt Plates with (3) 12mm Flat Washers, (3) 12mm Lock Washers and (3) 12mm Hex Nuts, **(Figure 6)**. Leave loose at this time.
4. Line up the remaining lower hole in the front Mounting Bracket with the hole in the inner body panel. Rotate the Bolt and Nut Plate until the threaded end (Nut) lines up with the hole in the body and the Mounting Bracket. Secure the Bracket to the nut with (1) 10mm x 35mm Hex Bolt, (1) 10mm Lock Washer and (1) 10mm Flat Washer, **(Figure 6)**. Do not tighten hardware at this time.
5. Repeat **Step 4** to finish attaching the remaining center and rear Brackets.
6. Move to the front Bracket location. Select (1) Driver/left Support Bracket, **(Figure 7)**. Bolt the bent end of the Bracket to the back of the Mounting Bracket with (1) 8mm Hex Bolt, (2) 8mm Flat Washers and (1) 8mm Nylon Lock Nut, **(Figure 8)**. Line up the flat end of the Support Bracket with the back of the pinch weld. Leave hardware loose at this time. Repeat this Step to install the center and rear Support Brackets.
7. Select the appropriate installation for your vehicle.

2009-12 models without holes in pinch weld:

- a) Adjust Mounting Brackets up or down to level the Running Board. Mark the location of the hole in the Support Bracket onto the back of the pinch weld, **(Figure 8)**. **IMPORTANT:** Make sure that you do not mark or drill too close to the edge of the pinch weld.
- b) Repeat as necessary to line up and mark all Support Bracket locations.
- c) Move the (3) Support Brackets out of the way. Use a 5/16" (or 8mm) drill bit to drill through the pinch weld for all (3) Support Brackets. **IMPORTANT:** Do not drill for Support Brackets until after the Running Board has been completely installed and adjusted.

IMPORTANT: Any cutting or drilling tool may break or shatter. Government regulations require safety glasses & equipment at all times when cutting or drilling.

- d) Bolt each Support Bracket to the back of the pinch weld with (1) 8mm Hex Bolt, (2) 8mm Flat Washers and (1) 8mm Nylon Lock Nut, **(Figure 9)**. Skip to **Step 8**.

2013-14 models with factory holes through pinch weld:

- a) Line up the slot in the Support Bracket with the factory hole in the pinch weld.
- b) Bolt each Support Bracket to the back of the pinch weld with (1) 8mm Hex Bolt, (2) 8mm Flat Washers and (1) 8mm Nylon Lock Nut, **(Figure 9)**. Do not tighten hardware at this time.

8. Level and adjust the Running Board and fully tighten all hardware. Tighten 12mm hardware to 35-40ft-lbs, 10mm hardware to 27-30ft-lbs and 8mm hardware to 16-18ft-lbs.
9. Repeat **Steps 2—8** for passenger Running Board installation.
10. Do periodic inspections to the installation to make sure that all hardware is secure and tight.

To protect your investment, wax this product after installing. Regular waxing is recommended to add a protective layer over the finish. Do not use any type of polish or wax that may contain abrasives that could damage the finish.

For gloss black finishes: Mild soap may be used to clean the Running Board.

Driver Side Installation Pictured

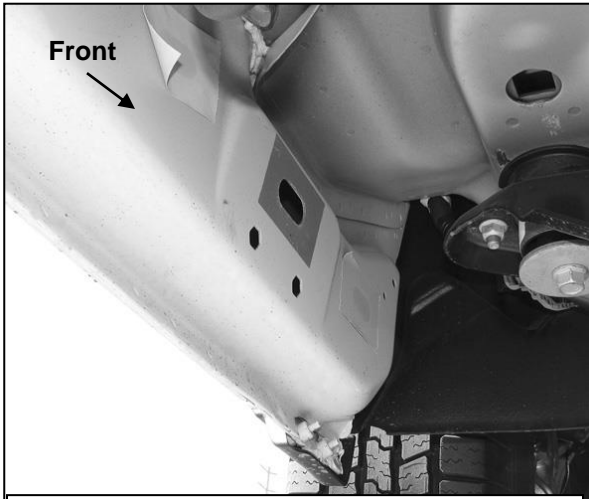

(Fig 1) Driver/Left front mounting location

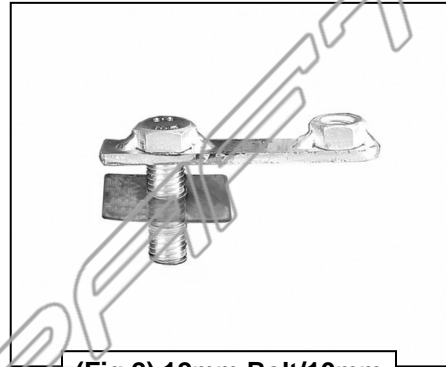

(Fig 2) 12mm Bolt/10mm
Nut Plate w-retainer

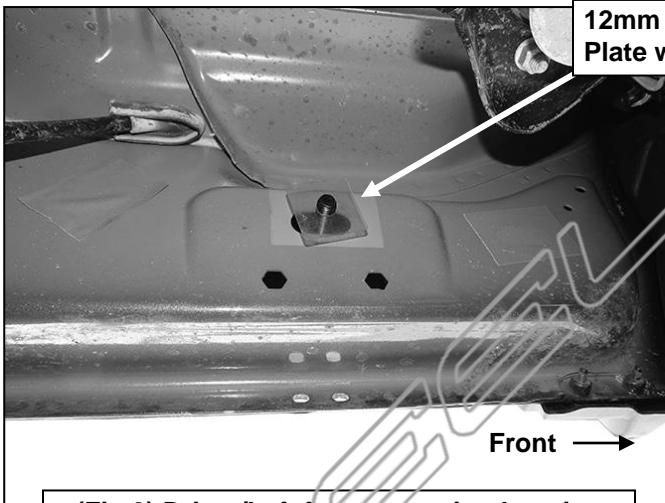

(Fig 3) Driver/Left front mounting location

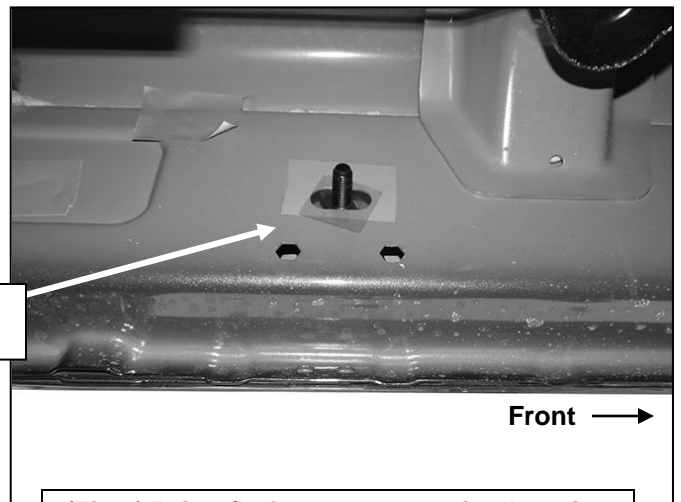

(Fig 4) Driver/Left center mounting location

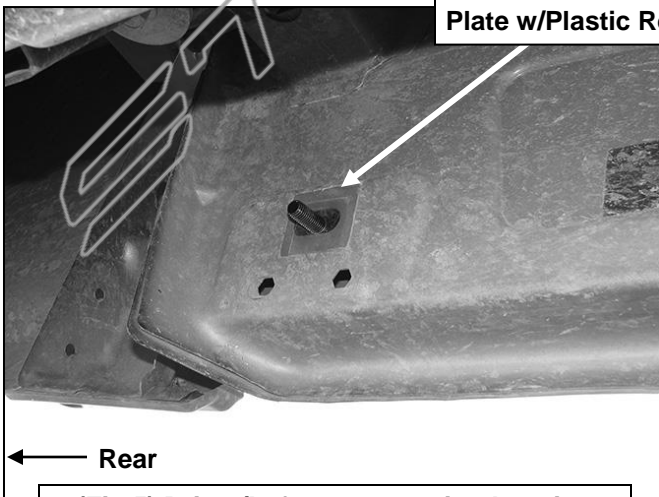

(Fig 5) Driver/Left rear mounting location

Driver Side Installation Pictured

10mm Hex Bolt
10mm Lock Washer
10mm Flat Washer

12mm Flat Washer
12mm Lock Washer
12mm Hex Nut

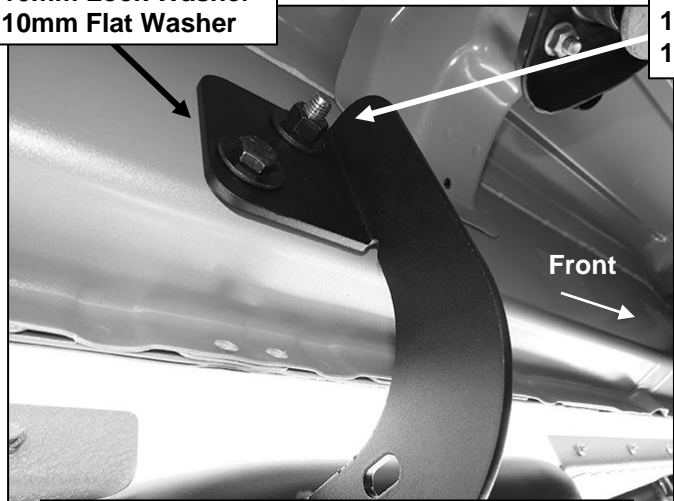

(Fig 6) Driver/Left center Mounting Bracket

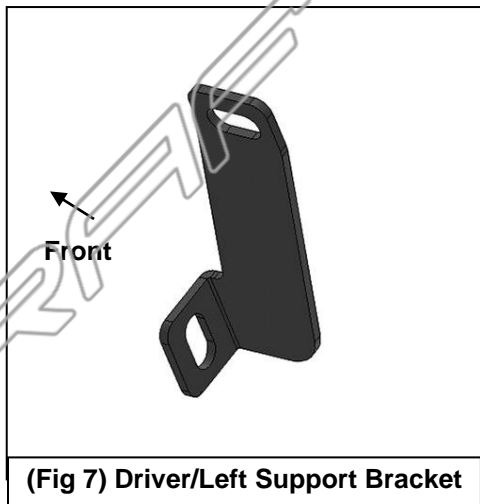

(Fig 7) Driver/Left Support Bracket

Models without factory holes, mark
Support Bracket location onto back of
pinch weld and drill with 5/16" drill bit

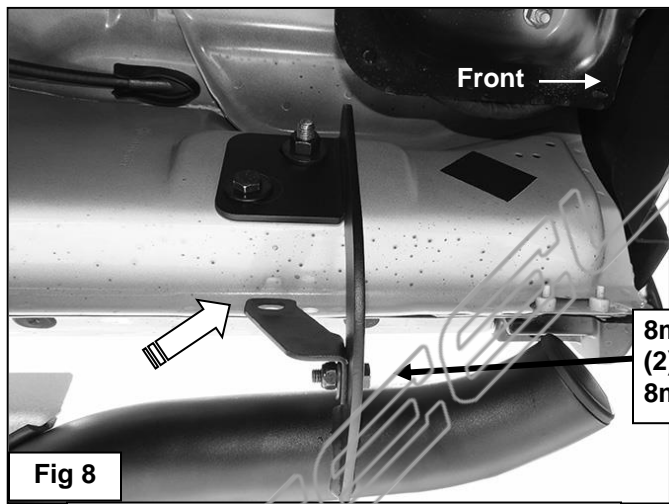

Fig 8

Push Support Bracket up to bend in body panel (arrow). Do not mark or drill close to the bottom edge of the pinch weld

8mm x 25mm Hex Bolt
(2) 8mm Flat Washers
8mm Nylon Lock Nut

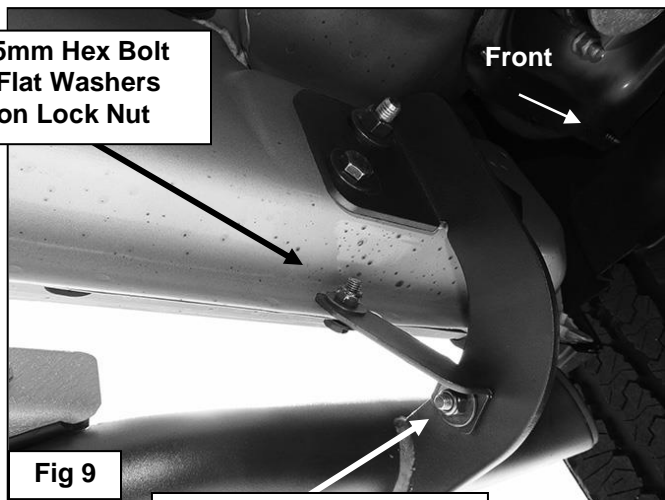

Fig 9

8mm x 25mm Hex Bolt
(2) 8mm Flat Washers
8mm Nylon Lock Nut



Installation Complete