

**VIEWPOINT RUNNING BOARDS
2007-13 FORD EDGE
EXCLUDES ALL MODELS WITH EXTENDED ROCKER PANEL COVERS INCLUDING ECOBOOST,
SPORT AND SL**

PARTS LIST:

1	Driver/Left Running Board	4	10-1.50mm x 30mm Flat Bolt Plate
1	Passenger/Right Running Board	2	8-1.25mm x 35mm Bolt Plate
1	Driver/Left Front Mounting Bracket	2	8mm Plastic Retainers
1	Passenger/Right Front Mounting Bracket	2	8mm Threaded Inserts
2	Front Support Brackets	1	8mm Insert Tool
1	Driver/Left Center Mounting Bracket	10	10mm x 27mm OD x 3mm Large Flat Washers
1	Passenger/Right Center Mounting Bracket	10	10mm Nylon Lock Nuts
1	Driver/Left Center Support Bracket	11	8-1.25mm x 30mm Hex Bolts
1	Passenger/Right Center Support Bracket	18	8mm x 24mm OD x 2mm Flat washers
1	Driver/Left Rear Mounting Bracket	10	8mm Lock Washers
1	Passenger/Right Rear Mounting Bracket	10	8mm Hex Nuts
1	Driver/Left Rear Support Bracket	12	6-1.0mm x 20mm T-Bolts
1	Passenger/Right Rear Support Bracket	12	6mm x 22mm OD x 2mm Flat Washers
2	10-1.50mm x 35mm Long Double Bent Bolt Plate	12	6mm Lock Washers
2	10-1.50mm x 25mm Short Double Bent Bolt Plate	12	6mm Hex Nuts
2	10-1.50mm x 35mm Bent Bolt Plate		

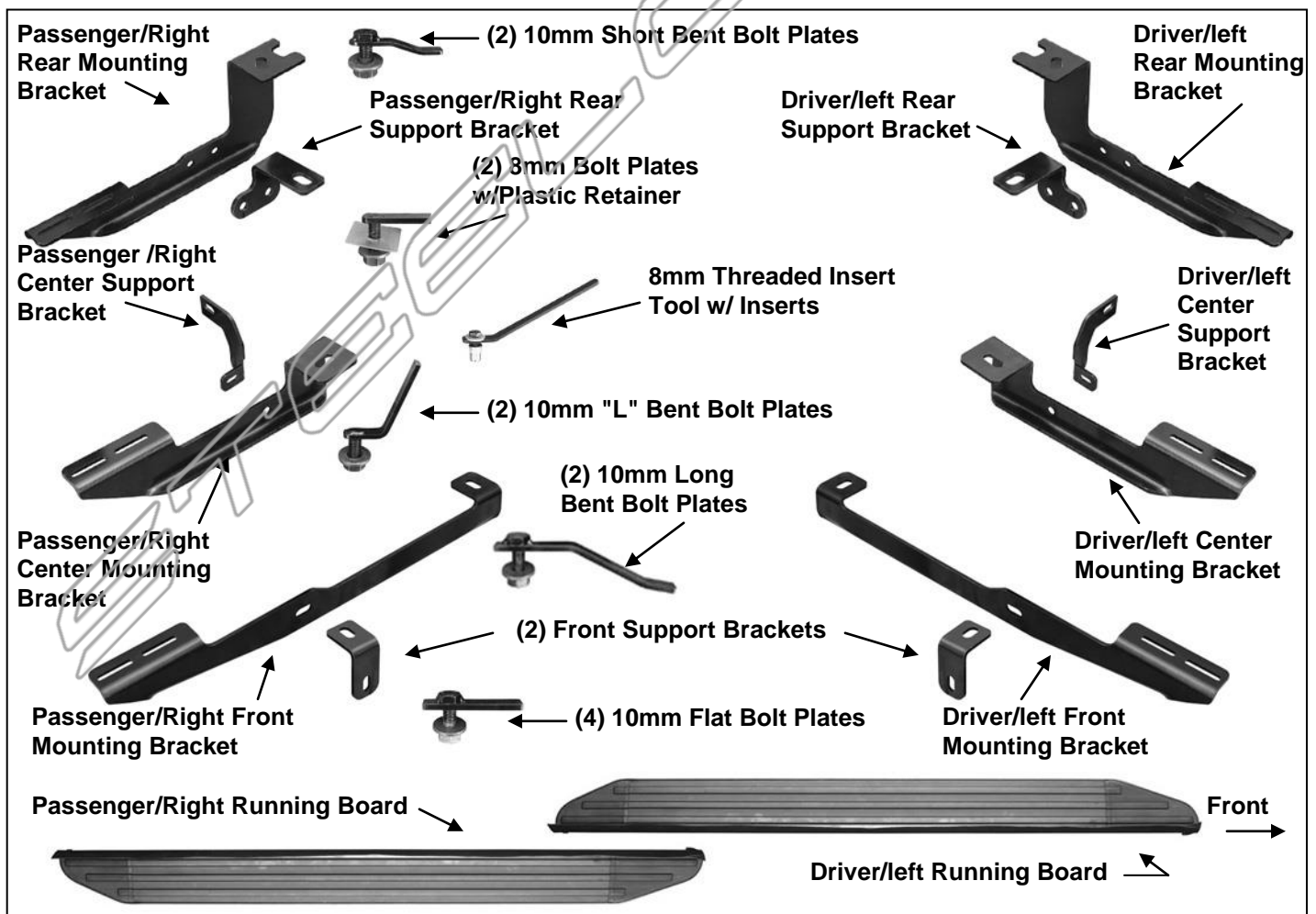

PROCEDURE:

1. REMOVE CONTENTS FROM BOX. VERIFY ALL PARTS ARE PRESENT. READ INSTRUCTIONS CAREFULLY BEFORE STARTING INSTALLATION. CUTTING AND/OR DRILLING MAY BE REQUIRED. ASSISTANCE IS RECOMMENDED.
2. Start installation under the driver side of the vehicle. Locate the oval hole toward the front wheel opening next to the pinch weld. Insert (1) 10mm x 30mm Flat Bolt Plate into the factory hole, (**Figures 1A & 1B**). Select the driver side front Support Bracket, (**Figure 2A**). Attach the Bracket to the Bolt Plate with (1) 10mm Flat Washer and (1) 10mm Nylon Lock Nut, (**Figure 2B**). Do not tighten hardware.
3. Temporarily remove the plastic cover if equipped. Locate the oval and square holes in the bottom of the inner frame channel, (**Figure 3B**). Select (1) 10mm Long Double Bent Bolt Plate, (**Figure 3A**). Insert the Bolt Plate into the oval hole and out the square hole in the inner frame channel, (**Figure 3B**).
4. Move along the side of the vehicle to the center body reinforcement. Select (1) 10mm "L" Bent Bolt Plate, (**Figure 4A**). Insert the Bolt Plate into the vertical slot in the back of the reinforcement and down through the hole in the bottom, (**Figure 4B**). Attach the driver side Center Bracket to the Bolt Plate with (1) 10mm Flat Washer and (1) 10mm Nylon Lock Nut, (**Figure 5**). Snug but do not fully tighten hardware at this time.
5. Determine the correct Center Support Bracket procedure for your vehicle.

2007-11 Models:

- a. Select the driver side Center Support Bracket. Bolt the Support Bracket to the back of the Center Bracket with (1) 8mm Hex Bolt, (2) 8mm Flat Washers, (1) 8mm Lock Washer and (1) 8mm Hex Nut, (**Figure 5**). Snug but do not fully tighten hardware at this time.
- b. Make sure the Center Bracket is in the proper position, straight and level. Tighten the 10mm Bolt Plate hardware first. Firmly hold the Support Bracket up in place against the back of the body panel and tighten the 8mm hardware.
- c. Mark the mounting hole location onto the back of the body panel, (**Figure 5**). Remove both Center Brackets.
- d. Drill a 7/16" hole through the center of the marked location. **IMPORTANT!** Any cutting or drilling tool may break or shatter. Government regulations require safety glasses & equipment at all times when cutting or drilling.
- e. Assemble the Insert tool as pictured in **Figure 6**. Firmly hold handle on the tool and push the Insert into the drilled hole. **NOTE:** If the insert is too tight to install, (push into hole), by hand, lightly tap into position with small hammer. Do not damage the Insert.
- f. Once inserted into drilled hole, hold the Insert in place with the handle and tighten the 8mm Hex Bolt with a wrench to compress/expand the Insert in the body panel, (**Figure 7A**). Once the Insert is fully compressed, remove the bolt and tool from the Insert. **WARNING:** Do not overtighten hex bolt or insert may be damaged.
- g. Reinstall the Center Mounting Bracket and Support Bracket, (**Figure 7B**). Bolt the tab on the Support Bracket to the Insert with (1) 8mm Hex Bolt, (1) 8mm Lock Washer and (1) 8mm Flat Washer, (**Figure 8**). Leave hardware loose at this time.

2012-13 Models:

- a. Select (1) 8mm Low Profile Bolt Plate and (1) 8mm Plastic Retainer, (**Figure 9A**). Partially thread the Retainer onto the Bolt Plate. **IMPORTANT:** The Plastic Retainer is designed to prevent the Bolt Plate from falling into the body panel and to aid in installing the Bracket.
- b. Insert the Bolt Plate into the hole in the back of the body panel with Retainer on outside, (**Figure 9B**). Hold the threaded end of the Bolt Plate and thread the Retainer down tight against the panel.
- c. Select the driver side Center Support Bracket. Secure the Support Bracket to the Bolt Plate with (1) 8mm Flat Washer, (1) 8mm Lock Washer and (1) 8mm Hex Nut, (**Figure 10**).
- d. Bolt the Support Bracket to the back of the Center Bracket with (1) 8mm Hex Bolt, (2) 8mm Flat Washers, (1) 8mm Lock Washer and (1) 8mm Hex Nut. Snug hardware.

EXCLUDES ALL MODELS WITH EXTENDED ROCKER PANEL COVERS INCLUDING ECOBOOST, SPORT AND SL

6. Hold the plastic cover up in the approximate position, **(Figure 11)**. Mark the location of the Center Brackets onto the cover. Cut the cover to first clear the Center Brackets.
7. Hold the front of the plastic cover up in position and trace the location of the inner front Bolt Plate, **(see Step 3)**, onto the inside of the cover. Cut a hole in the center of the marked section to clear the Bolt Plate. Hold the Cover up in place over the Bolt Plate to check location, **(Figure 12)**.
8. Attach the driver side Front Mounting Bracket to the back of the Support Bracket with (1) 8mm Hex Bolt, (2) 8mm Flat Washers, (1) 8mm Lock Washer and (1) 8mm Hex Nut, **(Figure 12)**. Hold the inner end of the Mounting Bracket up against the plastic cover and over the Bolt Plate. Trace the outline of the Bracket onto the cover, **(Figure 13A)**.
Remove the Mounting Bracket and cover. Cut out the traced area to clear the inner end of the front Bracket, **(Figure 13B)**. **IMPORTANT:** Do not cut off the mounting area for the clip. Only remove material required to clear the Bracket. Check the fit often. Reinstall the plastic cover over the Bolt Plate but leave loose at this time. Do not fully reattach the cover until Brackets are fully tightened, **(Step 16)**.
9. Reinstall the Front Bracket as described in **Step 3**. Attach the inner end of the front Mounting Bracket to the 10mm Bolt Plate with (1) 10mm Flat Washer and (1) 10mm Nylon Lock Nut, **(Figure 14)**. Trim the plastic cover to clear the Bracket as necessary. Do not fully tighten hardware at this time.
10. Move toward the rear mounting location on the vehicle. Locate the (2) holes in the inner floor panel, **(Figure 15)**. Insert (1) 10mm x 25mm Short Bent Bolt Plate into the large hole and out the smaller, outer hole, **(Figures 16A & 16B)**. **NOTE:** Hold the driver side Rear Mounting Bracket in position to determine the correct mounting holes to use.
11. Next, locate the oval hole next to the pinch weld, **(Figure 15)**. Insert (1) 10mm x 30mm Flat Bolt Plate into the factory hole in the outer frame channel as described in **Step 1**, **(Figures 17A & 17B)**. Select the driver side rear Support Bracket. Attach the Support Bracket to the outer Bolt Plate with (1) 10mm Flat Washer and (1) 10mm Nylon Lock Nut, **(Figure 18)**. Snug but do not fully tighten hardware.
12. Select the driver side Rear Mounting Bracket. Attach the Bracket to the Short Bent Bolt Plate with (1) 10mm Flat Washer and (1) 10mm Nylon Lock Nut, **(Figure 18)**. Do not tighten hardware at this time.
13. Bolt the Mounting Bracket to the back of the Support Bracket with (2) 8mm Hex Bolts, (4) 8mm Flat Washers, (2) 8mm Lock Washers and (2) 8mm Hex Nuts. Snug all hardware but do not fully tighten.
14. Carefully un-wrap the driver side Running Board. Insert (6) 6mm T-Bolts into the slots in the end of the channels, (3 T-Bolts per channel), on the bottom of the Running Board, **(Fig. 19)**. Hold the Running Board up in approximate position and slide the T-Bolts down to line up with the (3) Mounting Brackets. Tilt the Board up at a slight angle and push back against the vehicle until the T-Bolts fit into the slots in the Brackets. **NOTE:** It may be necessary to loosen and drop down the Brackets to install the Running Board.
15. Secure the Running Board to the Brackets with (6) 6mm Flat Washers, (6) 6mm Lock Washers and (6) 6mm Hex Nuts, **(Figures 20 & 21)**. Do not tighten hardware at this time.
16. Level and adjust the Running Board and tighten all hardware. Reinstall the plastic cover with the factory hardware.
17. Repeat **Steps 1 - 16** for passenger/right Running Board installation. **NOTE:** On some model/years, passenger side may not be equipped with plastic cover.
18. Do periodic inspections to the installation to make sure that all hardware is secure and tight.

To protect your investment, wax this product after installing. Regular waxing is recommended to add a protective layer over the finish. Do not use any type of polish or wax that may contain abrasives that could damage the finish.

For stainless steel: Aluminum polish may be used to polish small scratches and scuffs on the finish. Mild soap may be used also to clean the Running Board.

**VIEWPOINT RUNNING BOARDS
2007-13 FORD EDGE
EXCLUDES ALL MODELS WITH EXTENDED ROCKER PANEL COVERS INCLUDING ECOBOOST,
SPORT AND SL**

**EXCLUDES ALL MODELS WITH EXTENDED ROCKER PANEL COVERS INCLUDING ECOBOOST,
SPORT AND SL**

Driver Side Installation Pictured

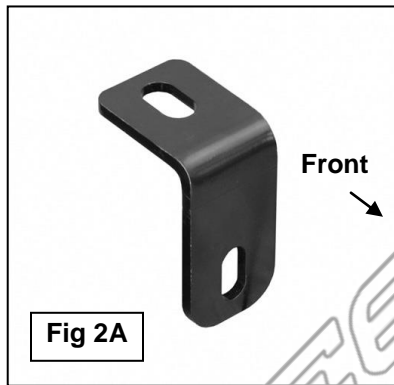
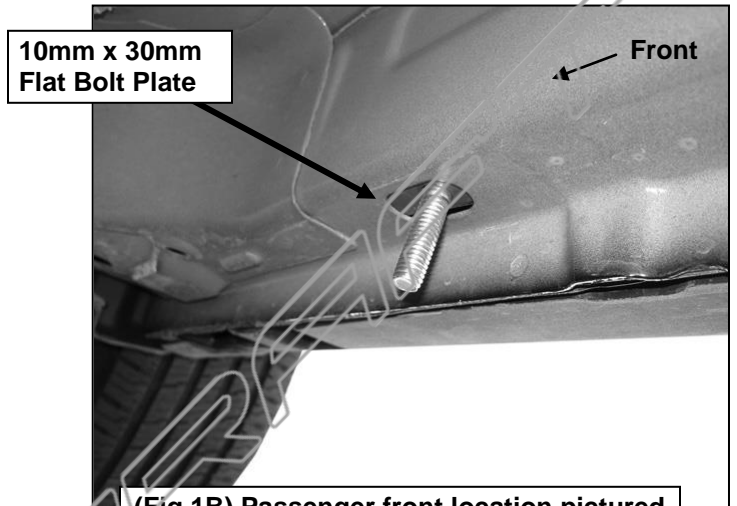
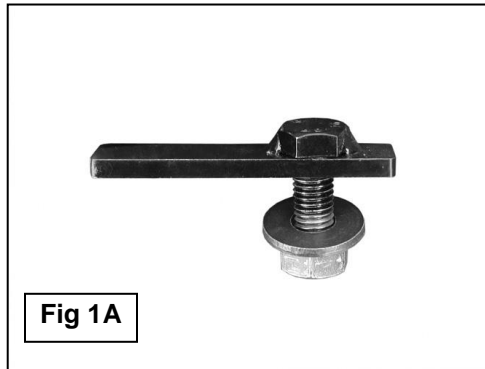

- (1) 10mm Flat Washer**
- (1) 10mm Nylon Lock Nut**

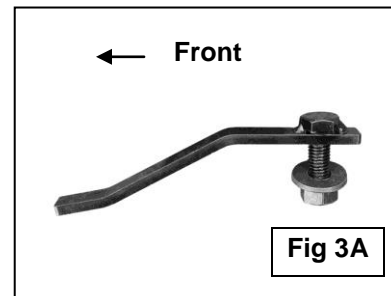
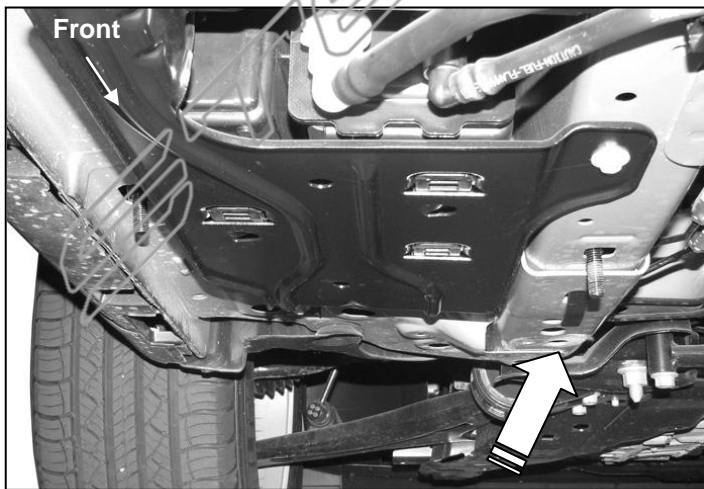
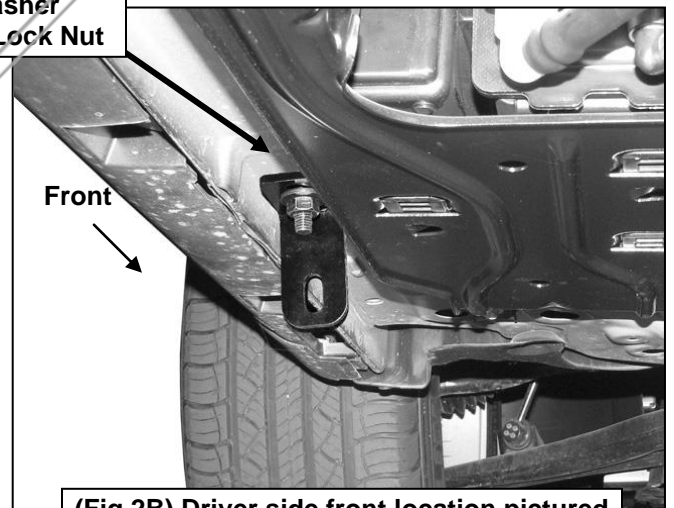

EXCLUDES ALL MODELS WITH EXTENDED ROCKER PANEL COVERS INCLUDING ECOBOOST,
SPORT AND SL

Driver Side Installation Pictured

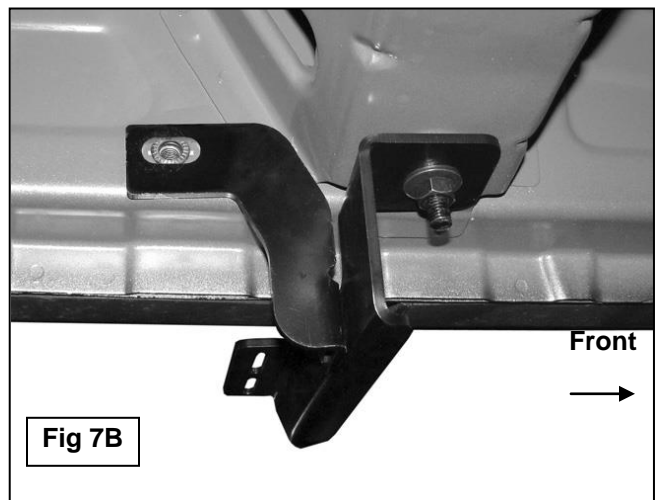
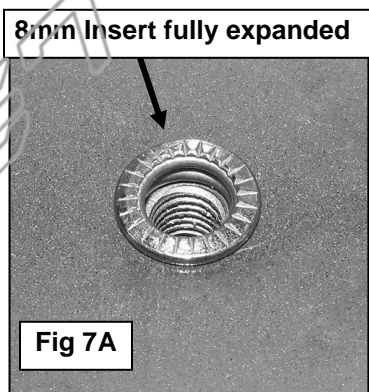
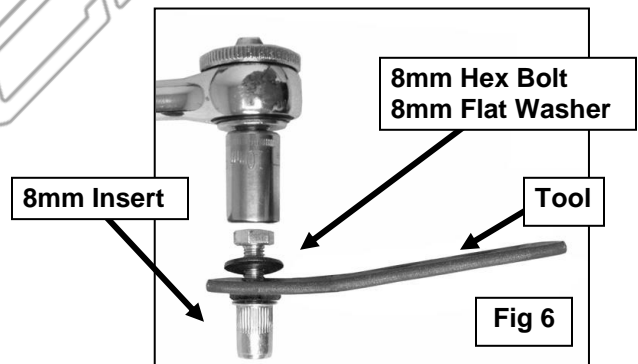
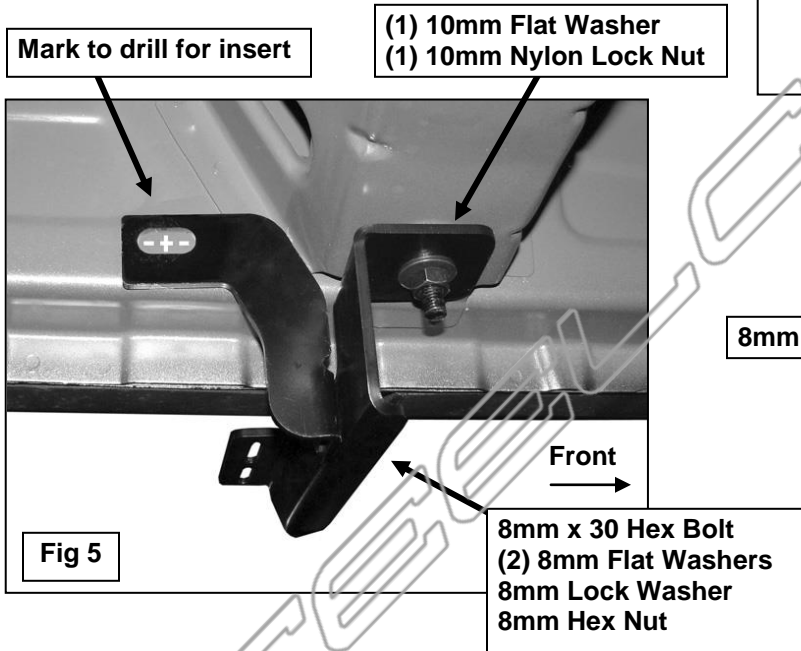
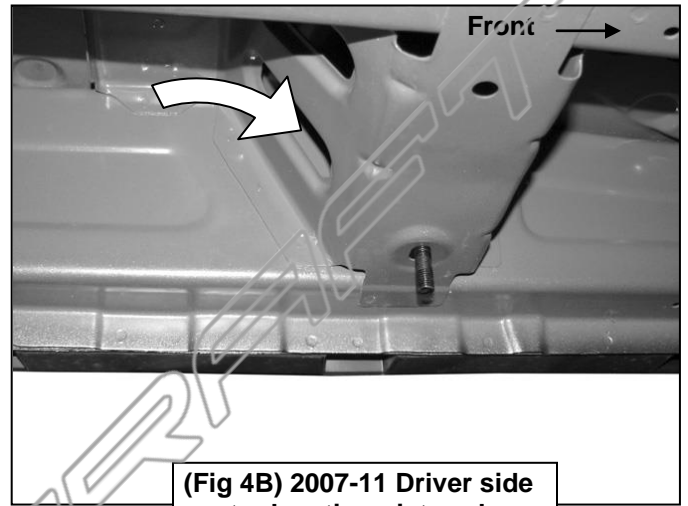

EXCLUDES ALL MODELS WITH EXTENDED ROCKER PANEL COVERS INCLUDING ECOBOOST,
SPORT AND SL

Driver Side Installation Pictured

8mm x 30 Hex Bolt
8mm Lock Washer
8mm Flat Washer

10mm Flat Washer
10mm Nylon Lock Nut

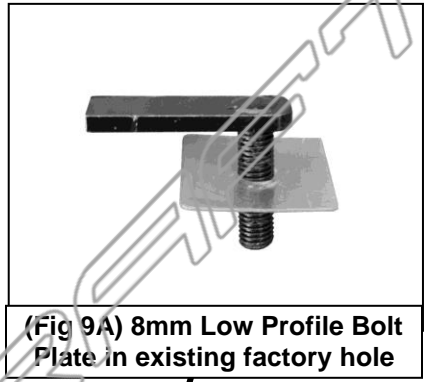
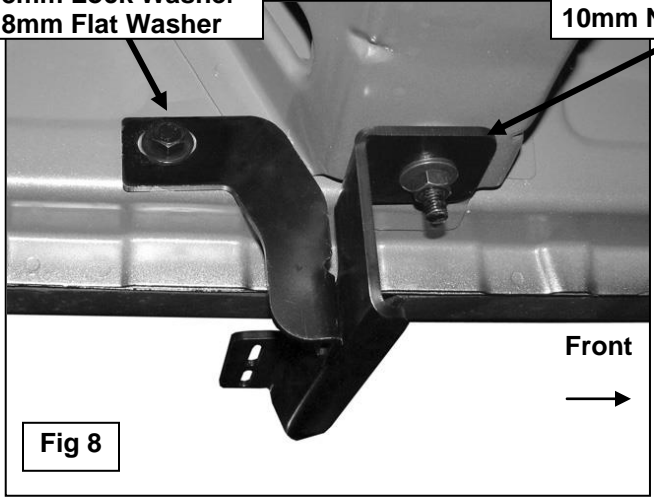

8mm Flat Washer
8mm Lock Washer
8mm Hex Nut

10mm Flat Washer
10mm Nylon Lock Nut

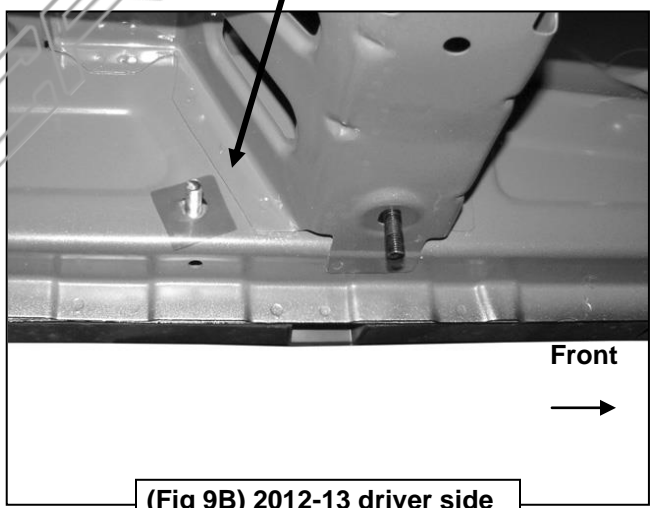
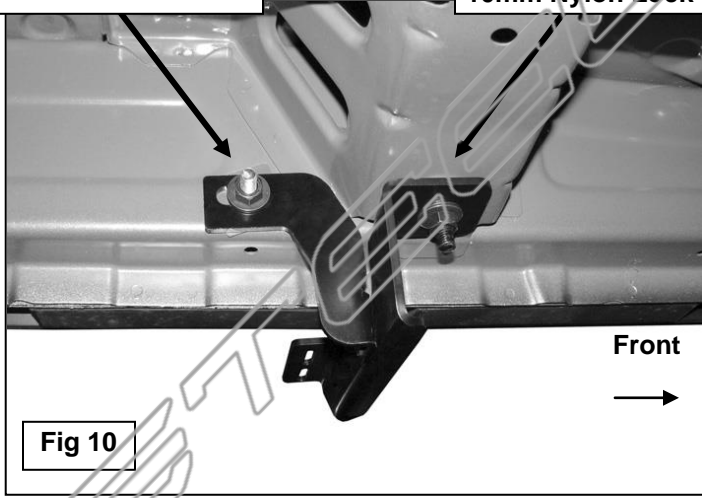

Once center Brackets have been installed,
hold plastic cover up in position and mark
location of Brackets onto cover. Carefully cut
out location with knife or hacksaw blade

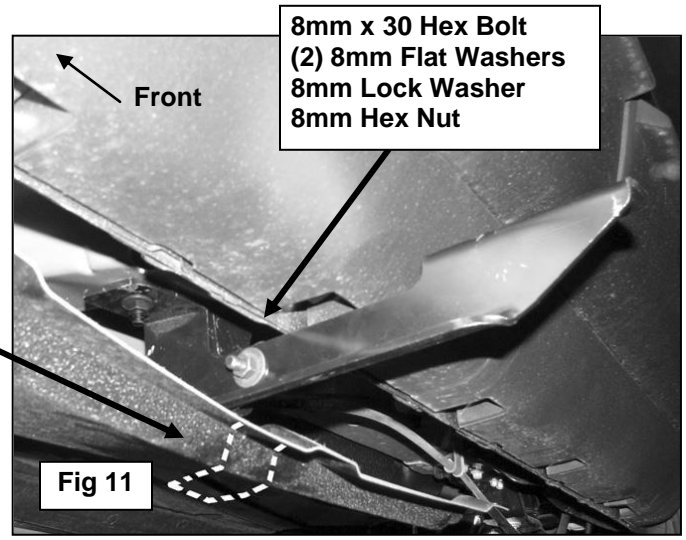

**VIEWPOINT RUNNING BOARDS
2007-13 FORD EDGE
EXCLUDES ALL MODELS WITH EXTENDED ROCKER PANEL COVERS INCLUDING ECOBOOST,
SPORT AND SL**

Driver Side Installation Pictured

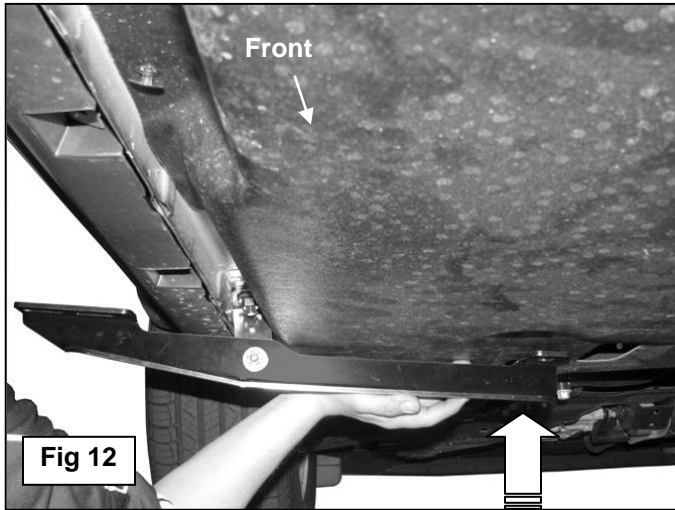

Hold front Bracket up to bottom of plastic cover. Trace outline of Bracket onto cover. Remove Bracket and cover. Carefully cut out location with knife or hacksaw blade

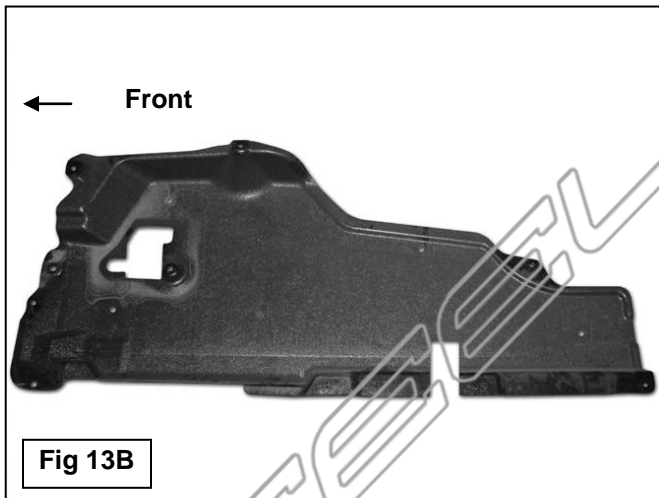
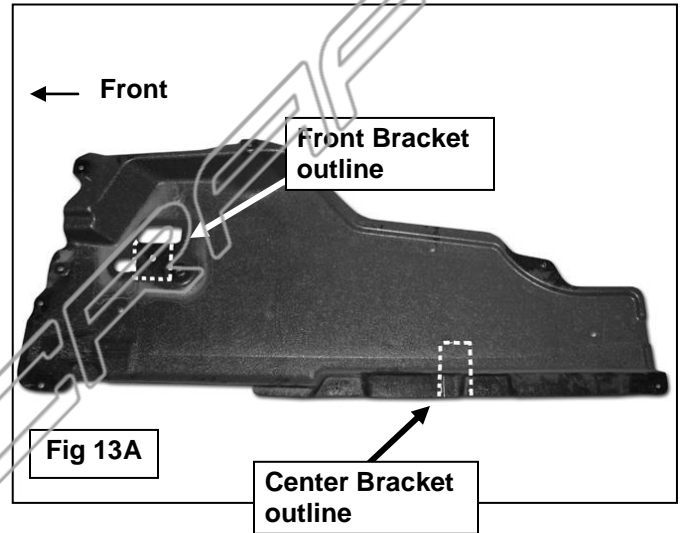

8mm x 30 Hex Bolt
(2) 8mm Flat Washers
8mm Lock Washer
8mm Hex Nut

10mm Flat Washer
10mm Nylon Lock Nut

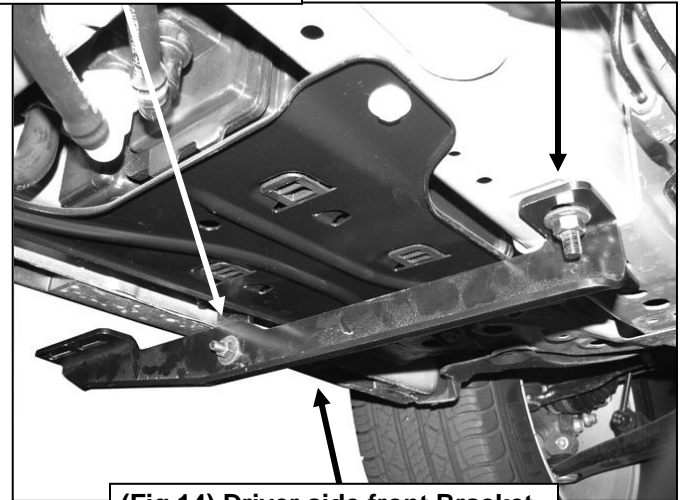

(Fig 14) Driver side front Bracket pictured installed without cover for instructions purposes only

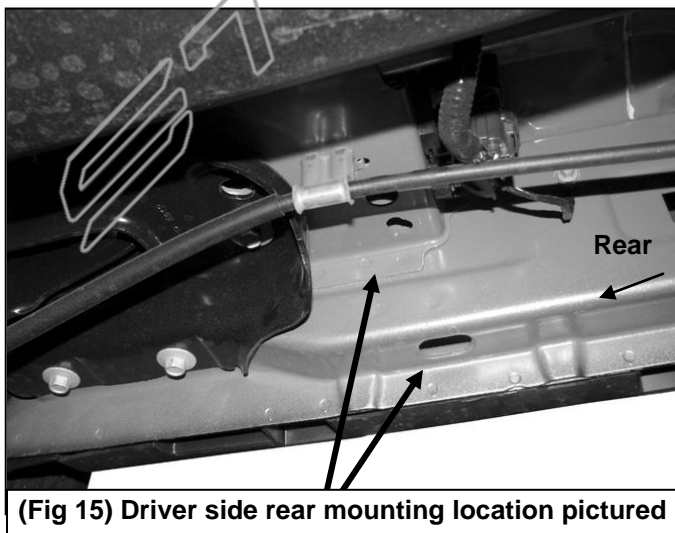

(Fig 15) Driver side rear mounting location pictured

**VIEWPOINT RUNNING BOARDS
2007-13 FORD EDGE
EXCLUDES ALL MODELS WITH EXTENDED ROCKER PANEL COVERS INCLUDING ECOBOOST,
SPORT AND SL**

**EXCLUDES ALL MODELS WITH EXTENDED ROCKER PANEL COVERS INCLUDING ECOBOOST,
SPORT AND SL**



(Fig 16A) 10mm Short Bent Bolt Plate

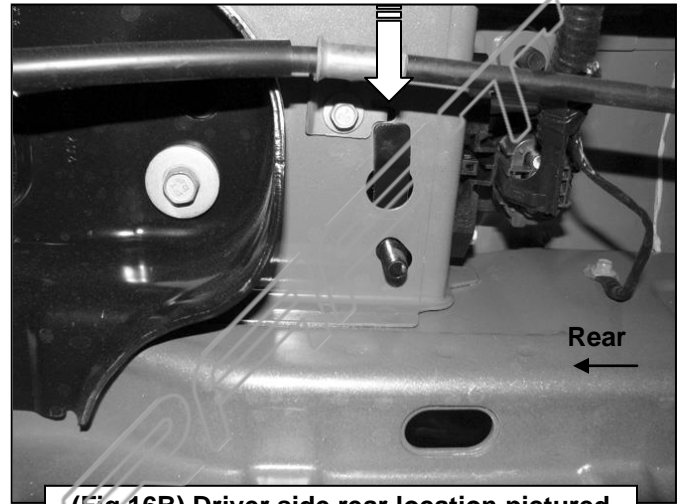

(Fig 16B) Driver side rear location pictured

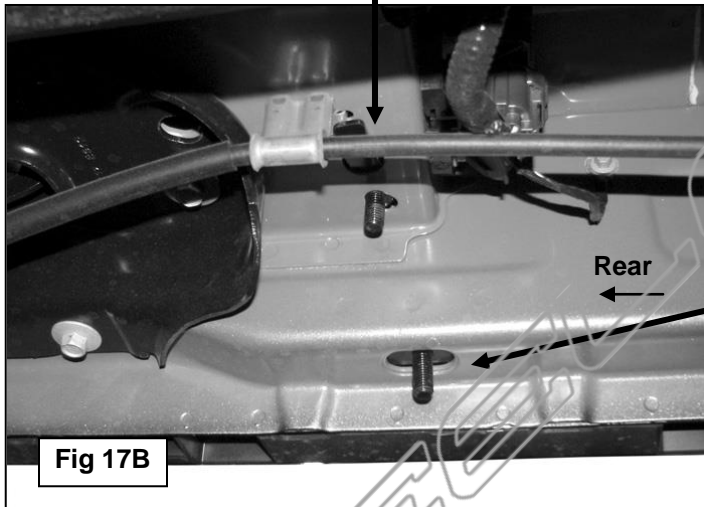
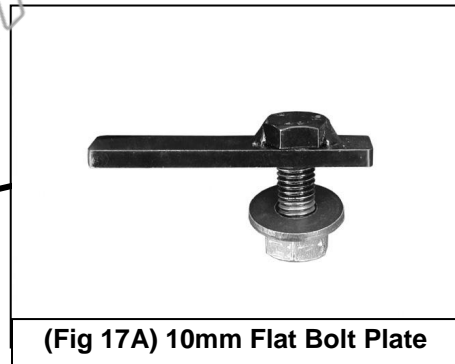

Fig 17B



(Fig 17A) 10mm Flat Bolt Plate

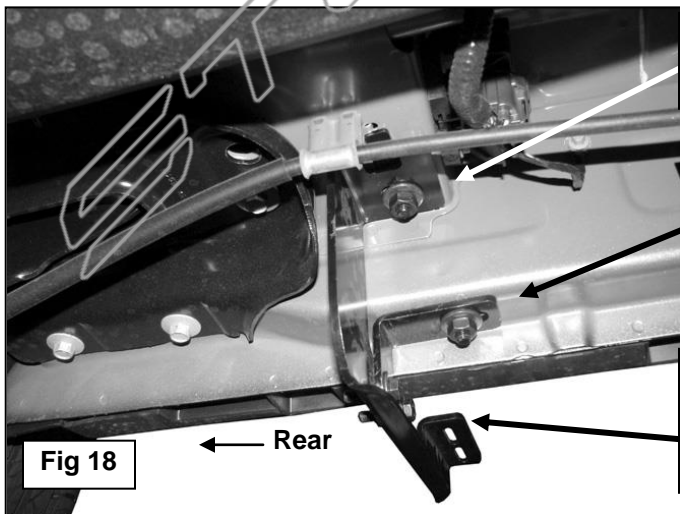

Fig 18

**10mm Flat Washer
10mm Nylon Lock Nut**

**Driver side rear Support Bracket
10mm Flat Washer
10mm Nylon Lock Nut**

**(2) 8mm x 30 Hex Bolts
(4) 8mm Flat Washers
(2) 8mm Lock Washers
(2) 8mm Hex Nuts**

EXCLUDES ALL MODELS WITH EXTENDED ROCKER PANEL COVERS INCLUDING ECOBOOST,
SPORT AND SL

Driver Side Installation Pictured

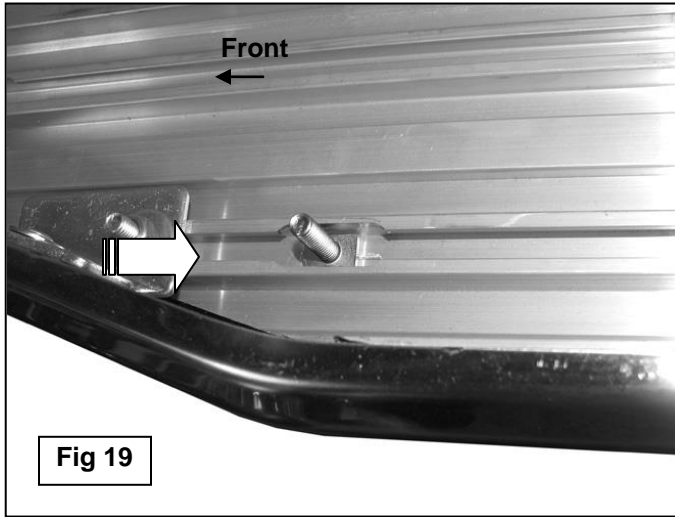

- (2) 6mm Flat Washers
- (2) 6mm Lock Washers
- (2) 6mm Hex Nuts

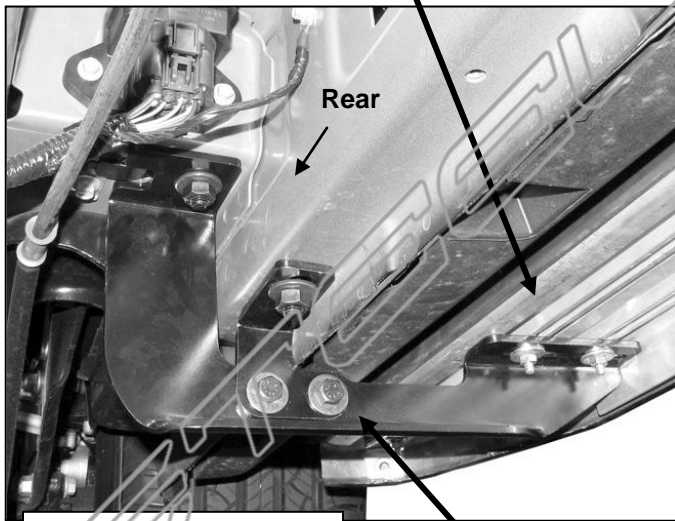
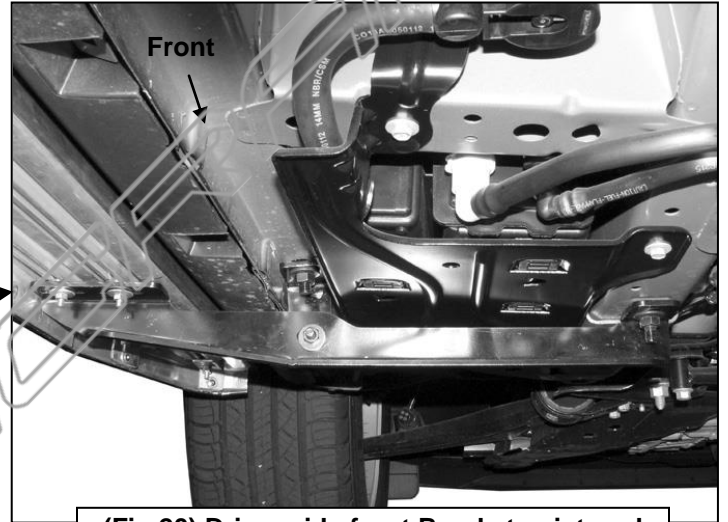

- (2) 8mm x 30 Hex Bolts
- (4) 8mm Flat Washers
- (2) 8mm Lock Washers
- (2) 8mm Hex Nuts

