

STX300 RUNNING BOARD BRACKET KIT
02-08 DODGE RAM 1500 QUAD CAB
03-09 RAM 2500-3500 QUAD CAB

PARTS LIST:

2	Driver/left Front/Rear Mounting Brackets	6	10mm Lock Washer
2	Passenger/right Front/Rear Mounting Brackets	6	10mm Hex Nuts
1	Driver/left Center Mounting Bracket	12	8-1.25mm x 25mm Hex Bolts
1	Passenger/right Center Mounting Bracket	12	8mm x 22mm x 2mm Washers
3	Driver/left Support Brackets	12	8mm x 16mm x 1.6mm Washers
3	Passenger/right Support Brackets	12	8-1.25mm Nylon Lock Nuts
6	10mm x 35mm Bolt Plates	12	6mm T-Bolts
6	10mm Plastic Retainers	12	6mm x 22mm OD x 2mm Flat Washers
6	10mm x 34mm x 3mm Flat Washers	12	6mm Lock Washers
		12	6mm Hex Nuts

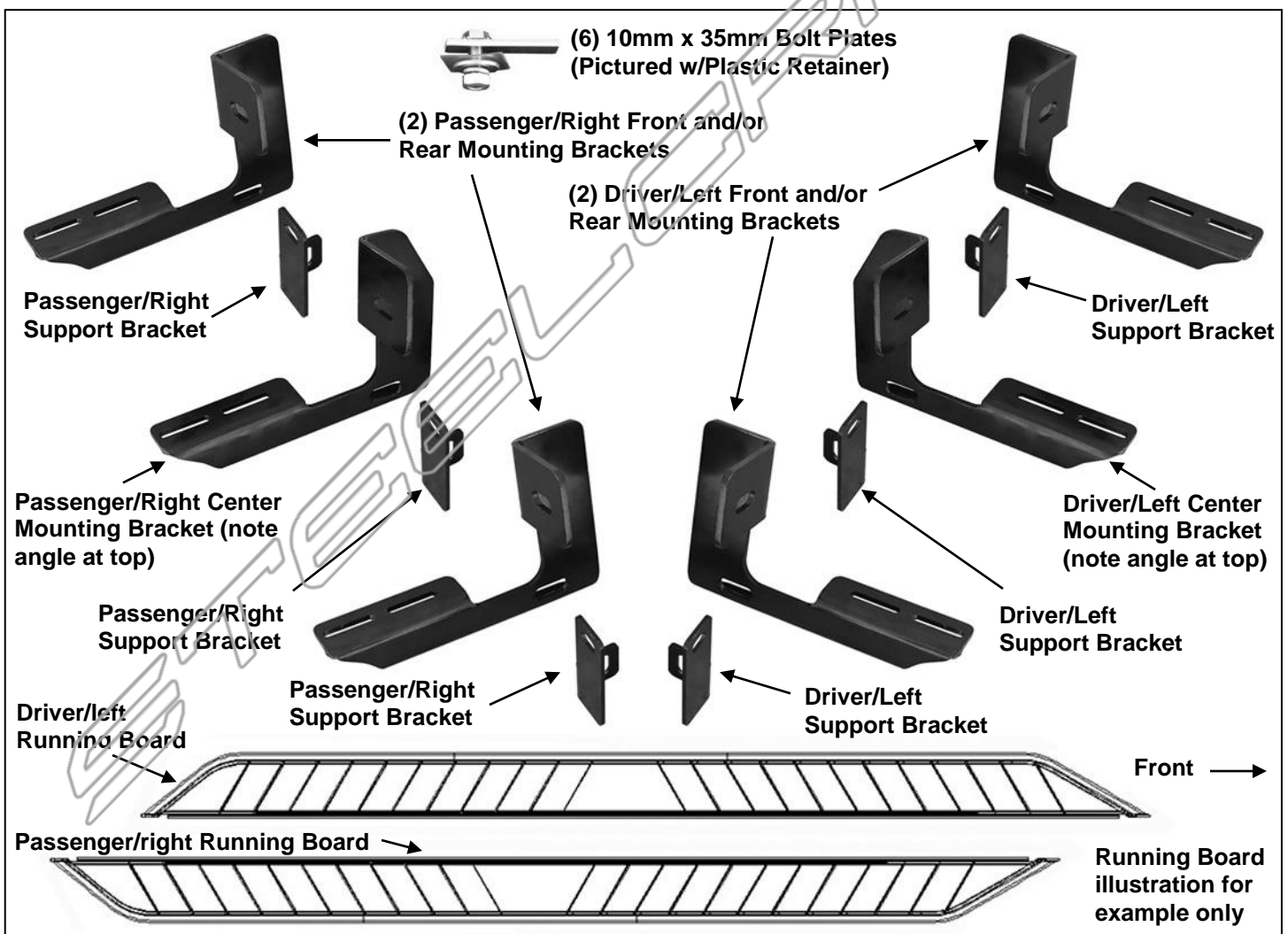

PROCEDURE:

- REMOVE CONTENTS FROM BOX. VERIFY ALL PARTS ARE PRESENT. READ INSTRUCTIONS CAREFULLY BEFORE STARTING INSTALLATION. DRILLING IS REQUIRED.**
- Starting toward the front of the driver side, locate the (2) oval holes in the inner body panel. Remove the tape covering the second factory hole, **(Figure 1)**. Thread (1) Plastic Retainer part way onto (1) 10mm x 35mm Bolt Plate, **(Figure 2)**. Insert the Bolt Plate into the factory hole on the rocker panel.

STX300 RUNNING BOARD BRACKET KIT
02-08 DODGE RAM 1500 QUAD CAB
03-09 RAM 2500-3500 QUAD CAB

Hold the Bolt Plate in place with one hand and continue to thread the Plastic Retainer down against the sheet metal until it holds the Bolt Plate in place, **(Figures 3 & 12)**. **IMPORTANT:** The Plastic Retainer is designed to prevent the Bolt Plate from falling into the body panel and to aid Bracket installation.

3. Select the driver side front Mounting Bracket, **(Figure 4A & 4B)**. **IMPORTANT:** The (3) driver side Brackets look similar but only the front and rear are the same and the center Bracket is unique. Use the illustration on **Page 1** and **Figure 4A** to properly identify the Brackets.
4. Attach the Bracket to the Bolt Plate with (1) 10mm Flat Washer, (1) 10mm Lock Washer and (1) 10mm Hex Nut, **(Figure 5)**. Do not fully tighten hardware at this time.
5. Next, select (1) driver side Support Bracket, **(Figure 6)**. Bolt the 90-degree bent end of the Support Bracket to the front of the Mounting Bracket with (1) 8mm x 25mm Hex Bolt (2) 8mm x 22mm STD Flat Washers and (1) 8mm Nylon Lock Nut, **(Figure 7)**. Do not fully tighten hardware at this time. **NOTE:** Place the flat end of the Support Bracket up against the pinch weld at the bottom of the body panel.
6. Move along the body toward the middle of the cab slightly ahead of where the front and rear doors meet. Locate the factory oval hole as described in **Step 2, (Figure 8)**. Select the driver side Center Bracket, **(Figure 9)**, and (1) driver side Support Bracket. Repeat **Steps 2—4** to install the driver side Center Brackets, **(Figure 10)**.
7. Next, move to the rear Mounting Bracket location toward the back of the cab. Remove the tape covering the second oval hole from the end of the cab, **(Figure 11)**. Repeat **Steps 2—4** to install the driver side rear Mounting Bracket, **(Figures 12 & 13)**.
8. Once all (3) Brackets and Support Brackets have been fully installed, select the driver side Running Board. **NOTE:** Angled end of Running Board is the front, **(see Page 1)**. Locate the two channels in the bottom of the Running Board. (3) 6mm T-Bolts are required for each channel. Slide T-Bolts into each channel, **(Figure 14)**.
9. Hold the Running Board up in approximate position and slide the T-Bolts along the channel to line up with the (3) Mounting Brackets. Tilt the Board up at a slight angle and push back against the vehicle until the T-Bolts fit into the slots in the Brackets.
10. Secure the Running Board to the Brackets with (6) 6mm Flat Washers, (6) 6mm Lock Washers and (6) 6mm Hex Nuts, **(Figures 17 & 19)**. Do not fully tighten hardware at this time. **NOTE:** The Running Board is designed to fit close to the vehicle. It may be necessary to loosen the Bracket hardware and tilt the Brackets downward to insert the Running Board between the Brackets and the body.
11. Level and adjust the Running Board and tighten all 10mm Mounting Bracket hardware.
12. Move to the front Bracket location. Move the Support Bracket up against the underside of the body and flat against the back of the pinch weld. Mark the location of the center of the slot onto the pinch weld, **(Figure 15)**. **IMPORTANT:** Make sure that you do not drill too close to the edge of the pinch weld. Adjust Mounting Brackets up or down to level the Running Board and line up the Support Brackets above the bottom edge of the pinch weld. Repeat as necessary to line up and mark all (3) Support Bracket locations, **(Figure 16)**.
13. Use a 5/16" (or 8mm) drill bit to drill through the pinch weld for all (3) Support Brackets. Bolt each Support Bracket to the back of the pinch weld with (1) 8mm Hex Bolt, (2) 8mm x 16mm Small Flat Washers and (1) 8mm Nylon Lock Nut, **(Figures 17—19)**.
14. Level and adjust the Running Board and fully tighten all hardware.
15. Repeat **Steps 2—14** for the passenger/right side Running Board installation.
16. Do periodic inspections to the installation to make sure that all hardware is secure and tight.

To protect your investment, wax this product after installing. Regular waxing is recommended to add a protective layer over the finish. Do not use any type of polish or wax that may contain abrasives that could damage the finish.

For stainless steel and aluminum: Aluminum polish may be used to polish small scratches and scuffs on the finish. Mild soap may be used also to clean the Running Board.

STX300 RUNNING BOARD BRACKET KIT
02-08 DODGE RAM 1500 QUAD CAB
03-09 RAM 2500-3500 QUAD CAB

Driver Side Installation Pictured

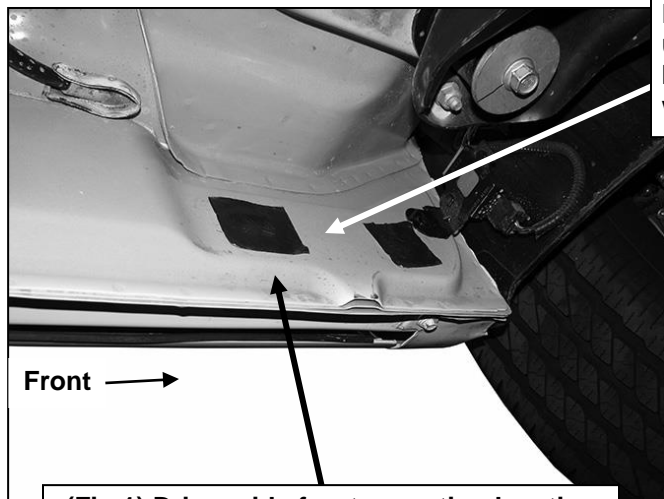

(Fig 1) Driver side front mounting location

Remove sealing tape to uncover mounting hole.
Insert 10mm Bolt Plate with 10mm Plastic Retainer

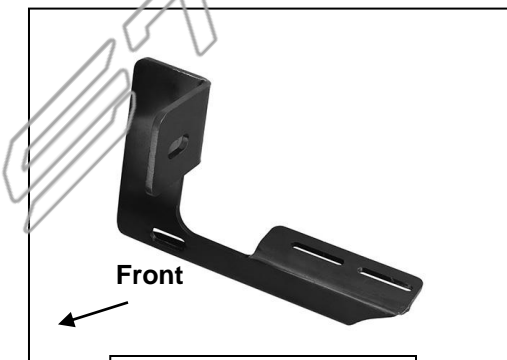
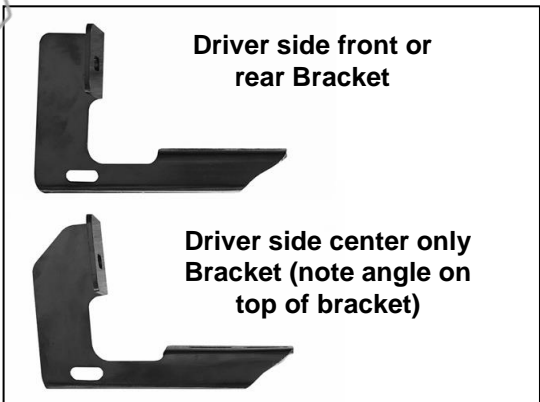
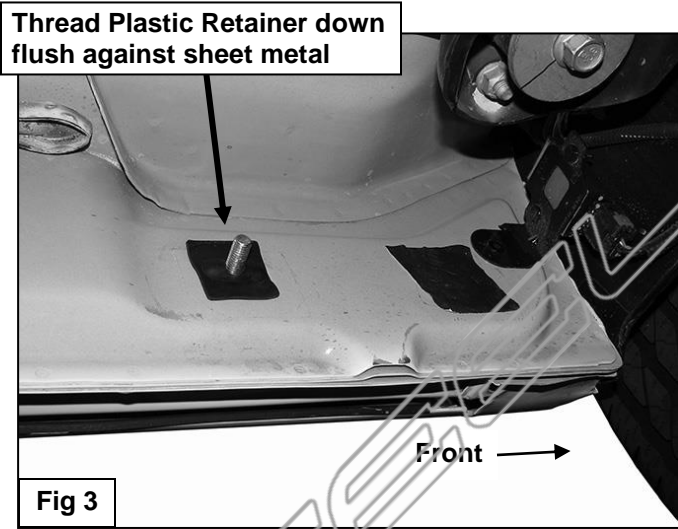
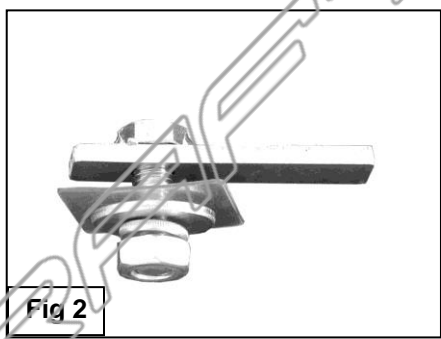

10mm Flat Washer
10mm Lock Washer
10mm Hex Nut

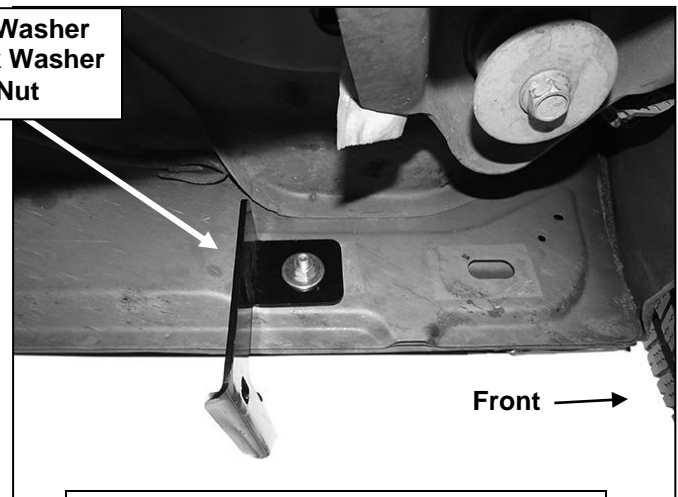

**STX300 RUNNING BOARD BRACKET KIT
02-08 DODGE RAM 1500 QUAD CAB
03-09 RAM 2500-3500 QUAD CAB**

Driver Side Installation Pictured



**(Fig 6) Driver side Support Bracket
(1 of 3)**

8mm x 25mm Hex Bolt
(2) 8mm x 22mm STD
Flat Washers
8mm Nylon Lock Nut

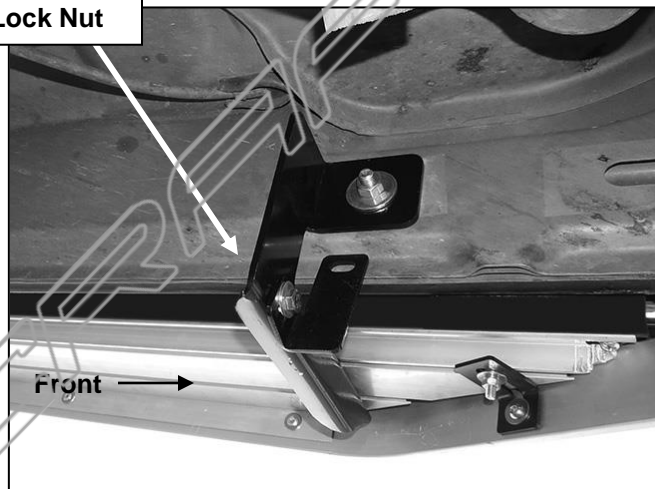

**(Fig 7) Driver side front Support Bracket installed-
Running Board pictured for reference only**

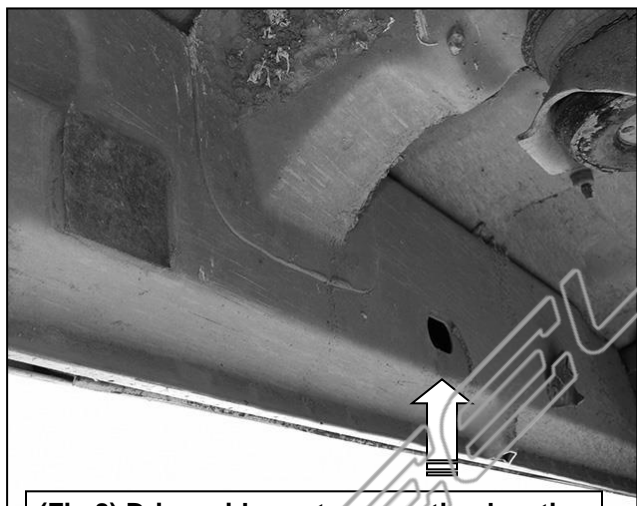

(Fig 8) Driver side center mounting location

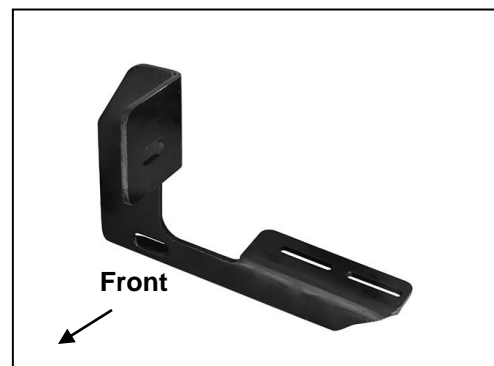

(Fig 9) Driver side center only Bracket

10mm Flat Washer
10mm Lock Washer
10mm Hex Nut

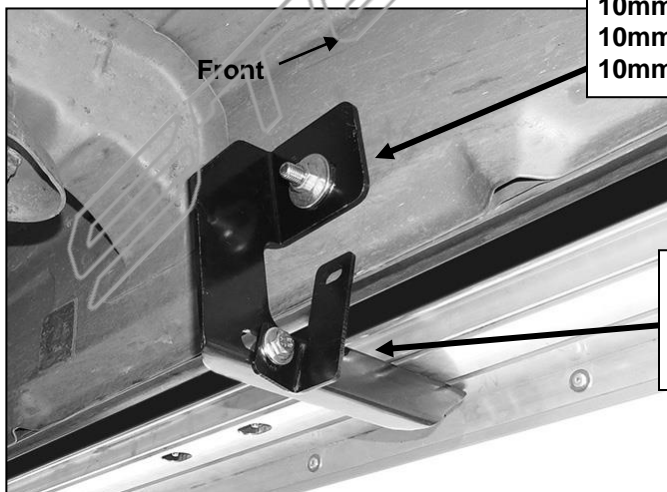

8mm x 25mm Hex Bolt
(2) 8mm x 22mm STD
Flat Washers
8mm Nylon Lock Nut

**(Fig 10) Driver side center Support Bracket
installed-Running Board pictured for reference only**

**STX300 RUNNING BOARD BRACKET KIT
02-08 DODGE RAM 1500 QUAD CAB
03-09 RAM 2500-3500 QUAD CAB**

Driver Side Installation Pictured

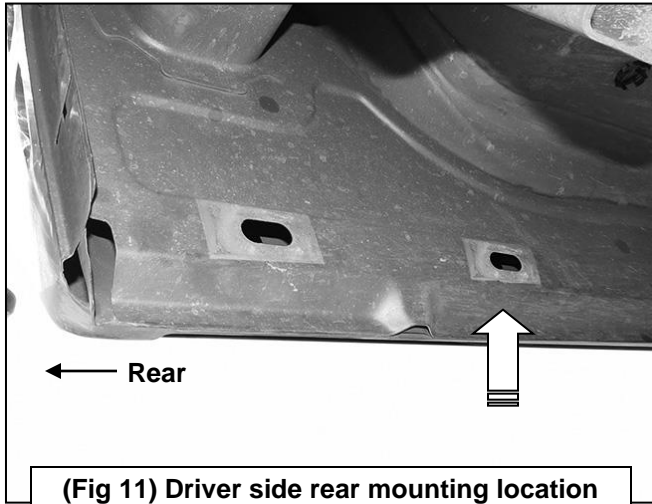

(Fig 11) Driver side rear mounting location

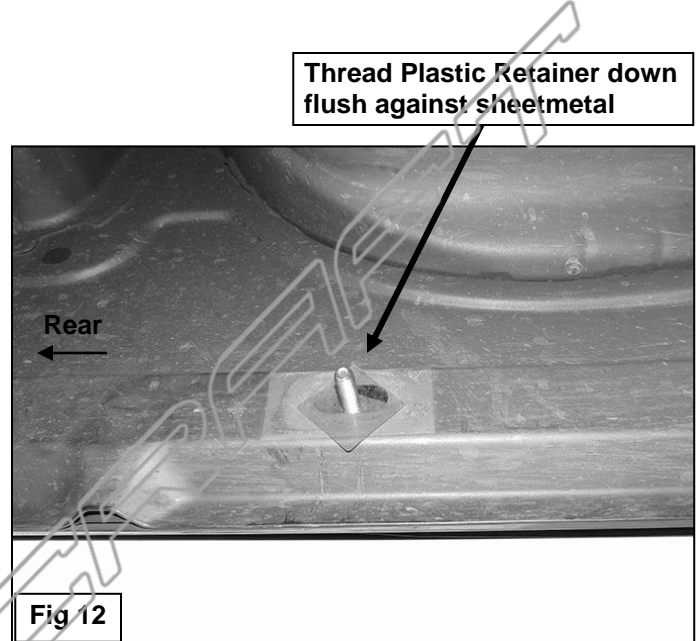

Thread Plastic Retainer down flush against sheetmetal

Fig 12

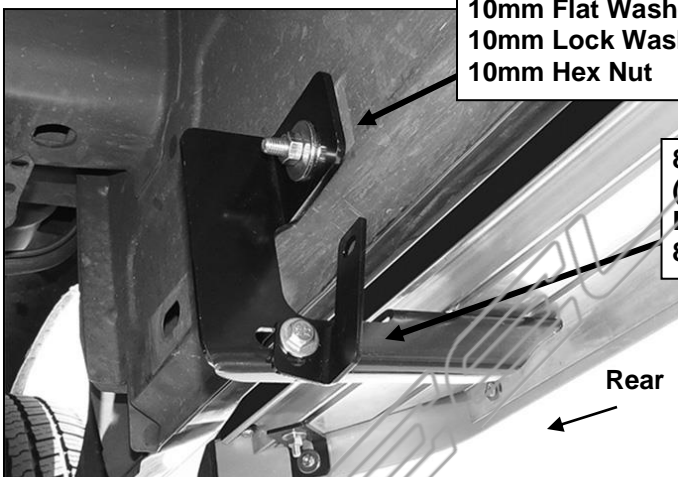

**10mm Flat Washer
10mm Lock Washer
10mm Hex Nut**

**8mm x 25mm Hex Bolt
(2) 8mm x 22mm STD Flat Washers
8mm Nylon Lock Nut**

(Fig 13) Driver side rear Support Bracket installed-Running Board pictured for reference only

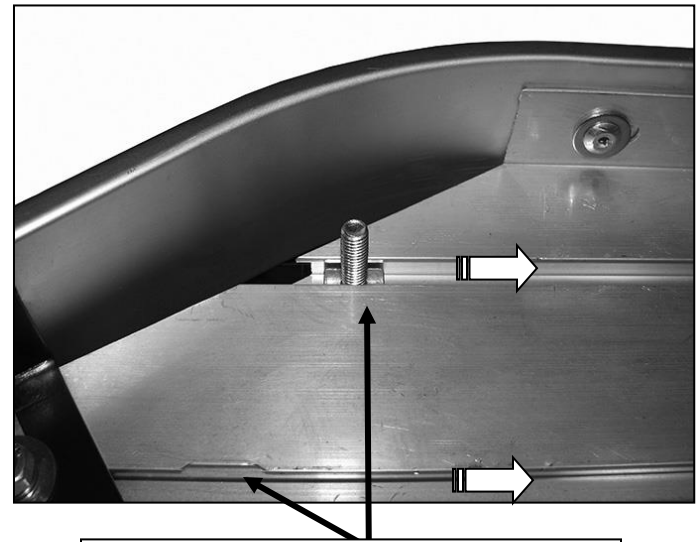

(Fig 14) Slide 6mm T-Bolts into channels

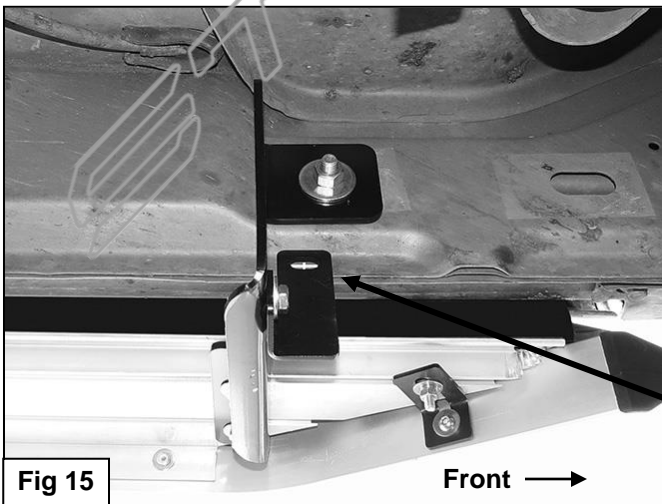

Fig 15

Front →

Mark and drill through pinch weld for all 3 driver side support Brackets after aligning-adjusting Running Board to vehicle

STX300 RUNNING BOARD BRACKET KIT
02-08 DODGE RAM 1500 QUAD CAB
03-09 RAM 2500-3500 QUAD CAB

Driver Side Installation Pictured

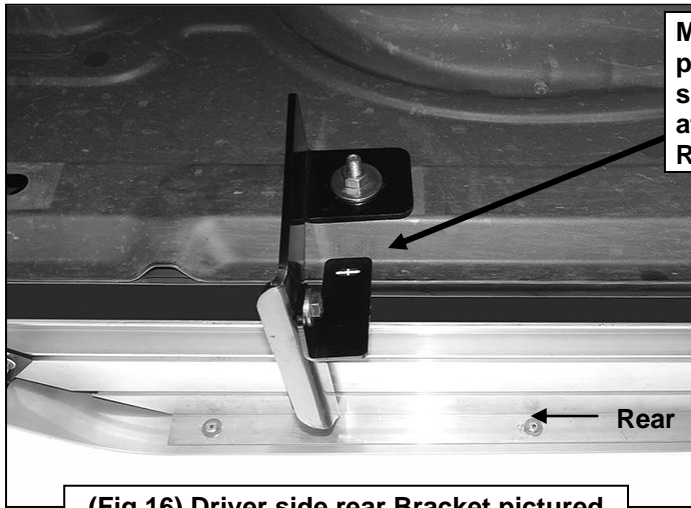

(Fig 16) Driver side rear Bracket pictured

Mark and drill through pinch weld for all 3 driver side support Brackets after aligning-adjusting Running Board to vehicle

8mm x 25mm Hex Bolt
(2) 8mm x 16mm Small Flat Washers
8mm Nylon Lock Nut

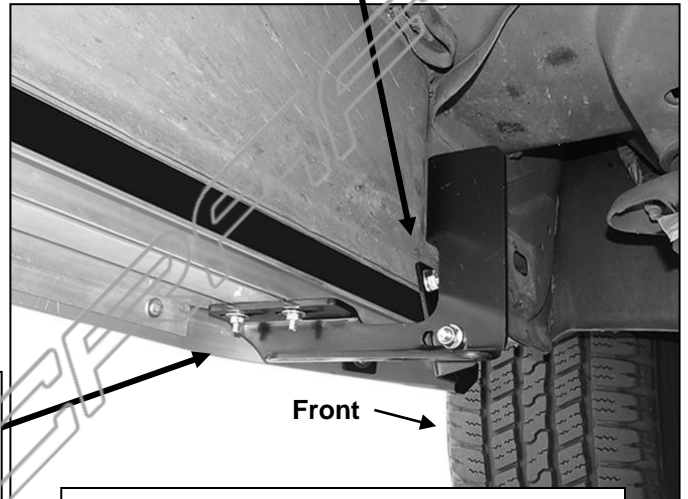

(Fig 17) Driver side front Bracket pictured

(2) 6mm T-Bolts
(2) 6mm Flat Washers
(2) 6mm Lock Washers
(2) 6mm Hex Nuts

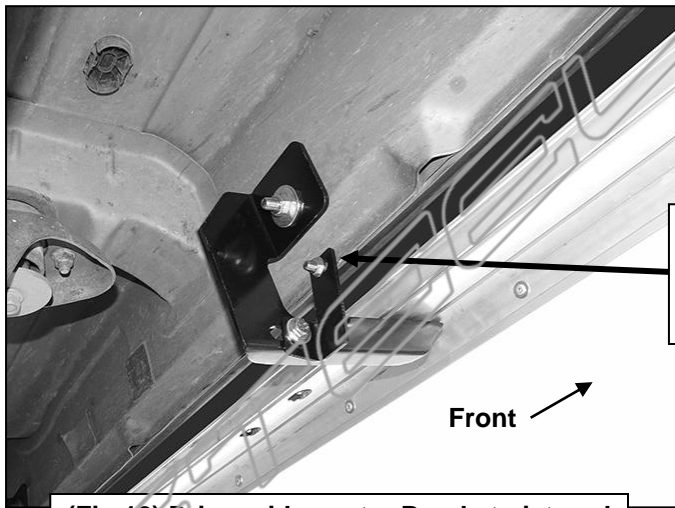

(Fig 18) Driver side center Bracket pictured

8mm x 25mm Hex Bolt
(2) 8mm x 16mm Small Flat Washers
8mm Nylon Lock Nut

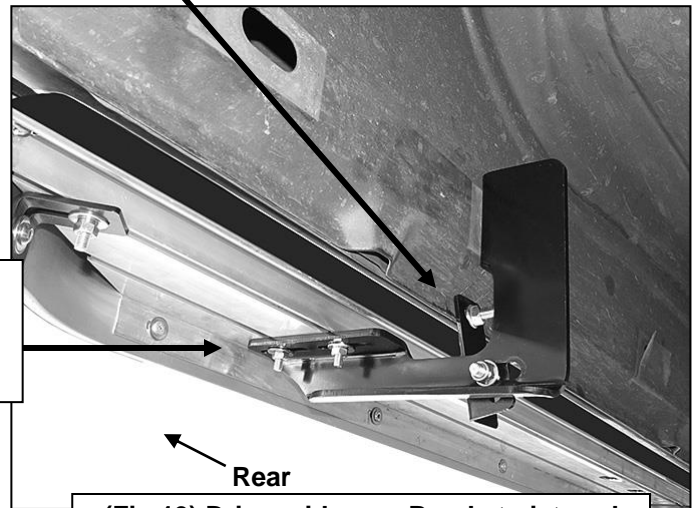

(Fig 19) Driver side rear Bracket pictured

(2) 6mm T-Bolts
(2) 6mm Flat Washers
(2) 6mm Lock Washers
(2) 6mm Hex Nuts