

INSTALLATION INSTRUCTIONS

**PIONEER RUNNING BOARD BRACKET KIT
09-15 DODGE RAM 1500 QUAD & CREW CABS
10-15 25-3500 QUAD, CREW & MEGA CABS**

STEELCRAFT

PARTS LIST:

1	Driver/Left Front Mounting Bracket	5	12mm Hex Nuts
1	Driver/Left Center Mounting Brackets	6	10-1.5mm x 35mm Hex Bolts
2	Driver/Left Front and Center Support Brackets	6	10mm x 27mm OD x 3mm Flat Washers
1	Driver/Left Rear Mounting Bracket	6	10mm Lock Washers
1	Driver/Left Rear Support Bracket (long)	6	8-1.25mm x 30mm Hex Bolts
2	Passenger/Right Front and Center Mounting Brackets	12	8-1.25mm x 25mm Hex Bolt
2	Passenger/Right Front and Center Support Brackets	30	8mm x 24mm x 2mm Flat Washer
1	Passenger/Right Rear Mounting Bracket	6	8mm Lock Washers
1	Passenger/Right Rear Support Bracket (long)	12	8-1.25mm Nylon Lock Nuts
6	12mm x 35mm Bolt x 10mm Nut Plates	12	6mm T-Bolts
6	12mm Plastic Retainers	12	6mm x 22mm OD x 2mm Flat Washers
5	12mm x 32mm OD x 3mm Flat Washers	12	6mm Lock Washers
5	12mm Lock Washers	12	6mm Hex Nuts

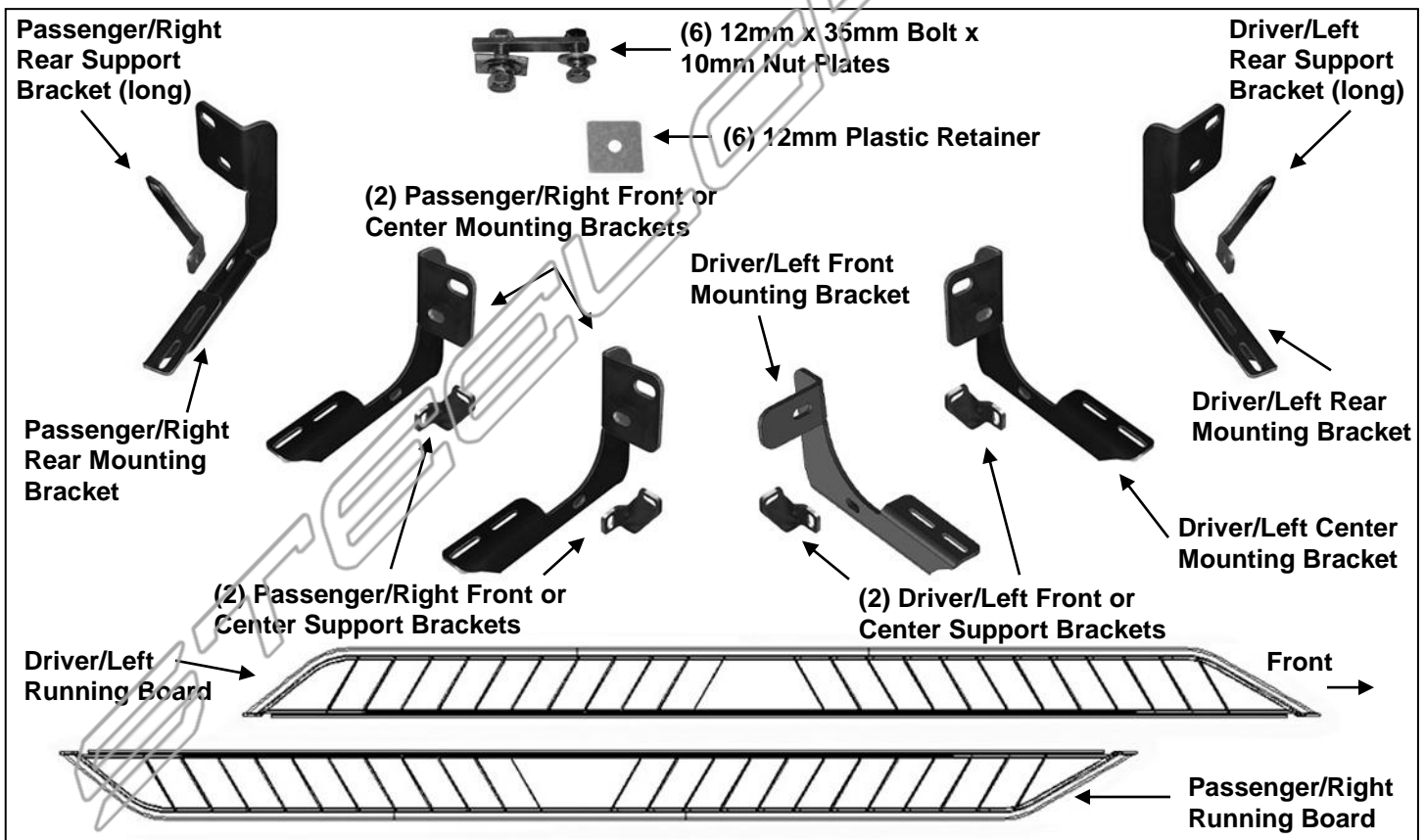

PROCEDURE:

REMOVE CONTENTS FROM BOX. VERIFY ALL PARTS ARE PRESENT. READ INSTRUCTIONS CAREFULLY BEFORE STARTING INSTALLATION. DRILLING IS REQUIRED ON 2009-12 1500, 2010-12 25-3500 MODELS.

1. Starting at the driver side-front of the vehicle, remove the sealing tape covering the factory holes on the side of the inner panel, **(Figure 1)**.
2. Determine the correct procedure to attach the driver side front Bracket for your model/year:
Models without factory threaded inserts in body panel (Figures 1 & 3):

- a. Partially thread a 12mm Plastic Retainer onto the threaded end of a 12mm Bolt and Nut Plate, **(Figure 2)**. Insert the Bolt and Nut Plate into the oval hole and tighten the Plastic Retainer, **(Figure 3)**. **NOTE:** The Plastic Retainer is designed to keep the Bolt/Nut Plate from falling into the body panel and to aid in Bracket installation.
- b. Select the driver side front Mounting Bracket, **(Figure 5)**. Rotate the 12mm Bolt and Nut plate until the threaded nut lines up with the hole in the Mounting Bracket and body, **(Figure 3)**. Attach the Bracket to the threaded Nut Plate with (1) 10mm x 35mm Hex Bolt, (1) 10mm Lock Washer and (1) 10mm Flat Washer, **(Figures 5 & 7)**. Do not fully tighten hardware at this time.

Models with factory threaded inserts:

- a. Attach the driver side Front Bracket to the threaded insert with (1) 8mm x 30mm Hex Bolt, (1) 8mm Lock Washer and (1) 8mm Flat Washer, **(Figures 4, 5 & 7)**. Leave hardware loose.
3. Next, select the driver side front Support Bracket, **(Figure 6)**. Attach the Bracket to the front of the front Bracket with (1) 8mm x 25mm Hex Bolt, (2) 8mm Flat Washers and (1) 8mm Nylon Lock Nut, **(Figures 5 & 7)**. Rotate the Support Bracket to the back of the pinch weld. Line up the slot in the top of the Support Bracket with the factory holes in the pinch weld. Attach the Bracket to the pinch weld with (1) 8mm x 25mm Hex Bolt, (2) 8mm Flat Washers and (1) 8mm Nylon Lock Nut, **(Figures 6 & 7)**. Do not fully tighten hardware at this time. **IMPORTANT:** 2009-12 models are not equipped with factory holes and will require drilling through the pinch weld to attach the Support Bracket, **(Figure 7)**. Do not drill through pinch weld at this time, **(see Step 10)**.
4. Move along the side of the body panel to the center mounting location, **(Figure 9)**. Select (1) 12mm Bolt/Nut Plate. Repeat **Step 2** to install the Bolt/Nut Plate. Select the driver side center Bracket **(Figure 10)**. Attach the Bracket to the Bolt/Nut Plate with (1) 12mm Flat Washer, (1) 12mm Lock Washer and (1) 12mm Hex Nut, **(Figure 14)**. Line up the remaining hole in the Bracket with the hole in the inner body panel. Rotate the Bolt and Nut Plate until the threaded end (Nut) lines up with the hole in the Bracket. Secure with (1) 10mm x 35mm Hex Bolt, (1) 10mm Lock Washer and (1) 10mm Flat Washer, **(Figure 9)**. Do not fully tighten hardware at this time.
 - a. **IMPORTANT NOTE:** Models with threaded insert, attach the Bracket to the threaded insert with (1) 8mm x 30mm Hex Bolt, (1) 8mm Lock Washer and (1) 8mm Flat Washer. The 10mm hardware will not be required **(Step 2)**. Snug but do not tighten hardware.
5. Repeat **Step 3** to install the center Support Bracket, **(Figures 6 & 14)**.
6. Move to the rear location, **(Figure 11)**. Repeat **Steps 4 & 5** to install the rear Mounting Bracket and Support Bracket, **(Figure 12)**. **VERY IMPORTANT:** The rear Brackets, **(Figure 10)**, are unique from the front and center brackets, (see illustration above-note bolt pattern on mounting plate).
7. Once all (3) Brackets have been installed, select the driver side Running Board. **NOTE:** Angled end of Running Board is the front, **(see Page 1)**. Locate the two channels in the bottom of the Running Board. (3) 6mm T-Bolts are required for each channel. Slide (3) T-Bolts into each channel, **(Figure 13)**.
8. Hold the Running Board up in approximate position and slide the T-Bolts along the channel to line up with the (3) Mounting Brackets. Tilt the Board up at a slight angle and push back against the vehicle until the T-Bolts fit into the slots in the Brackets.
9. Secure the Running Board to the Brackets with (6) 6mm Flat Washers, (6) 6mm Lock Washers and (6) 6mm Hex Nuts, **(Figures 14, 15 & 17)**. Leave hardware loose at this time. **NOTE:** The Running Board is designed to fit close to the vehicle. It may be necessary to loosen the Bracket hardware and tilt the Brackets downward to insert the Running Board between the Brackets and the body. Do not fully tighten hardware at this time.
10. Properly level and adjust the Running Board and fully tighten all hardware.

2009-12 models requiring drilling for Support Brackets:

 - a. Make sure the Running Board is level to the vehicle. Line up the slot on the Support Bracket with the back of the pinch weld. Mark the location of the slot onto the pinch weld, **(Figure 7)**.
 - b. Drill a 5/16" hole through the pinch weld. **IMPORTANT:** Do not drill too close to the bottom edge of the pinch weld. Drill the hole toward the center of the marked slot.
 - c. Attach each Support Bracket to the back of the pinch weld with (1) 8mm Hex Bolt, (2) 8mm Flat Washers and (1) 8mm Nylon Lock Nut, **(Figures 14—16)**. Repeat for all Support Brackets. Check for level then fully tighten all hardware.

11. Move to the passenger side of the vehicle. Remove tape covering front, center and rear locations. Repeat **Steps 4—10** for passenger side installation, (**Figures 16 & 17**). **NOTE:** Refer to **Figure 16** to identify the correct Mounting Bracket for each of the remaining locations. **IMPORTANT:** Passenger side front and center Brackets are identical. Fully tighten all hardware once installation is complete.
12. Do periodic inspections to the installation to make sure that all hardware is secure and tight.

To protect your investment, wax this product after installing. Regular waxing is recommended to add a protective layer over the finish. Do not use any type of polish or wax that may contain abrasives that could damage the finish. **For stainless steel and aluminum:** Aluminum polish may be used to polish small scratches and scuffs on the finish. Mild soap may be used also to clean the Running Board. Mild soap may be used to clean the Running Board.

Driver Side Installation Pictured

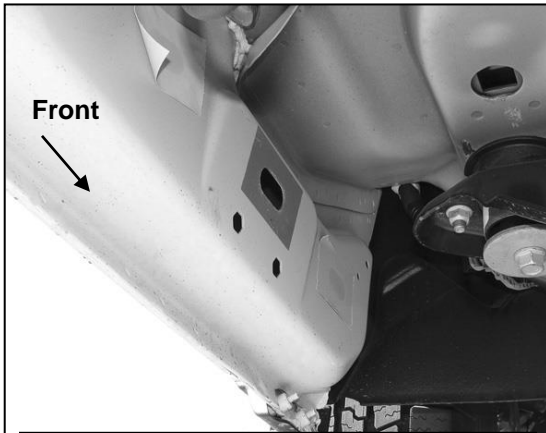

(Fig 1) Example of 2009-12 Driver/Left front mounting location

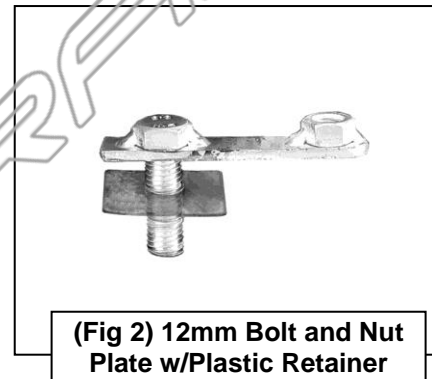

(Fig 2) 12mm Bolt and Nut Plate w/Plastic Retainer

Rotate Bolt/Nut Plate to line up correct threaded hole with body panel and hole in Mounting Bracket (see arrow)

12mm x 35mm Bolt/10mm Nut Plate
12mm Plastic Retainer

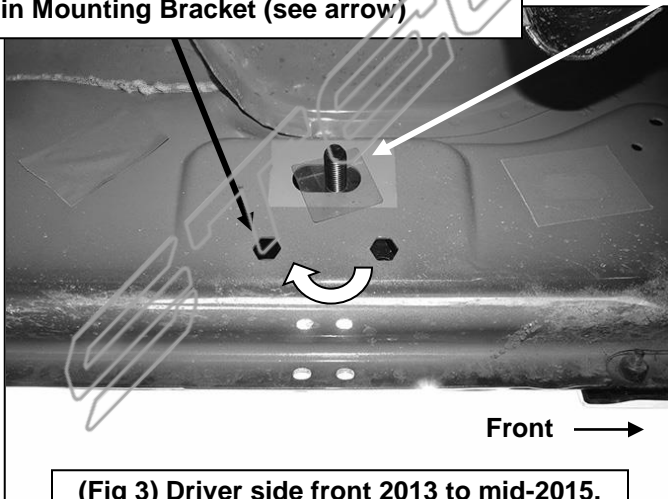

(Fig 3) Driver side front 2013 to mid-2015. **NOTE** no threaded insert in body panel

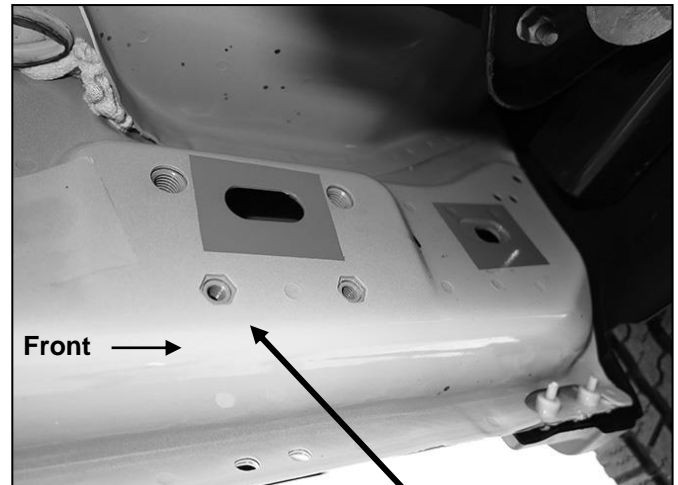

(Fig 4) Driver side front mid 2015-on example of all models with factory installed threaded inserts

Driver Side Installation Pictured

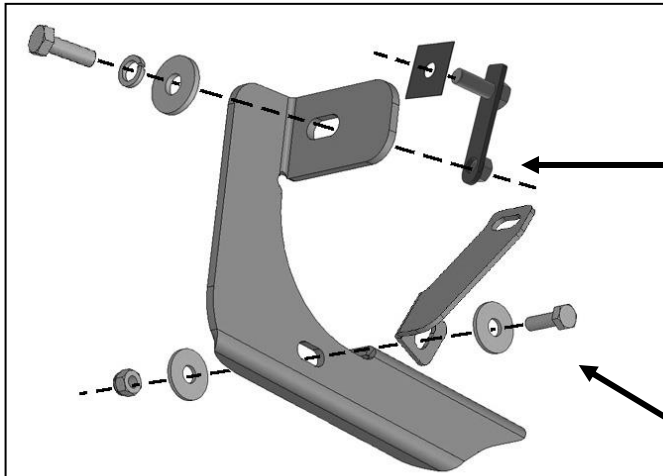

Models without threaded insert using Bolt/Nut Plate, use:
 10mm x 35mm Hex Bolt
 10mm Lock Washer
 10mm Flat Washer

Models with threaded insert use:
 8mm x 30mm Hex Bolt
 8mm Lock Washer
 8mm Flat Washer

8mm x 25mm Hex Bolt
 (2) 8mm Flat Washers
 8mm Nylon Lock Nut

(Fig 5) Driver/Left front Mounting Bracket assembly

2009-12 models: Mark the Support Bracket location onto back of pinch weld. Drill 5/16" hole through pinch weld.

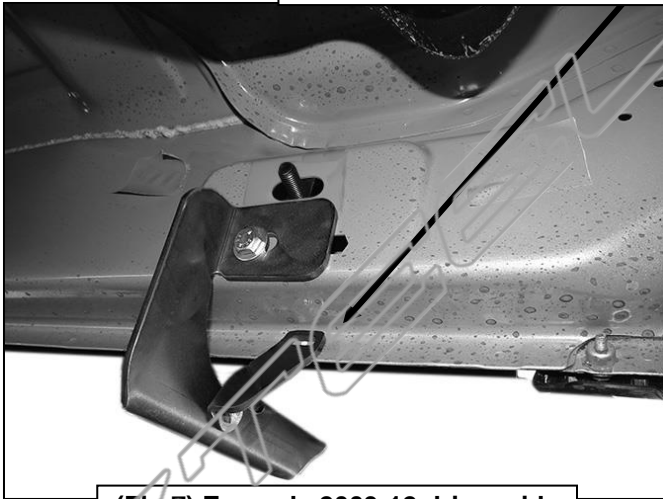

(Fig 7) Example 2009-12 driver side front without holes in pinch weld

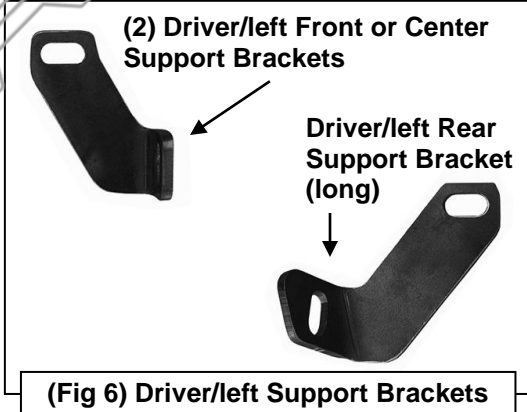

(Fig 6) Driver/left Support Brackets

8mm x 25mm Hex Bolts
 8mm Flat Washers
 8mm Lock Washers

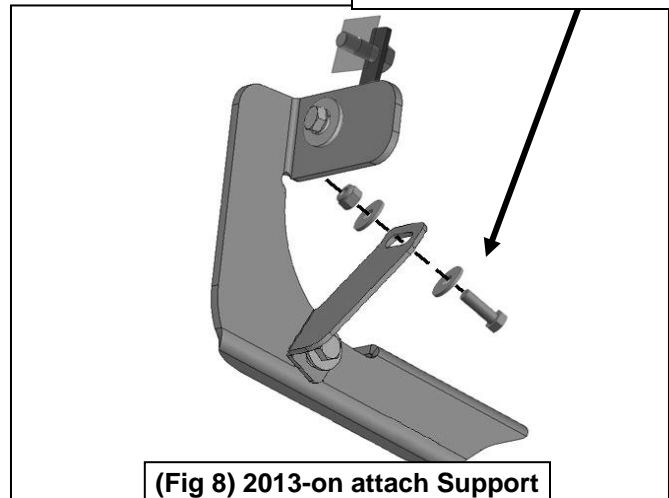

(Fig 8) 2013-on attach Support Bracket to back of pinch weld

2009-12 models only: Do not mark or drill holes for Support Brackets until after Running Board has been installed, properly adjusted and Mounting Bracket to Bolt Plate hardware fully tightened.

Driver Side Installation Pictured

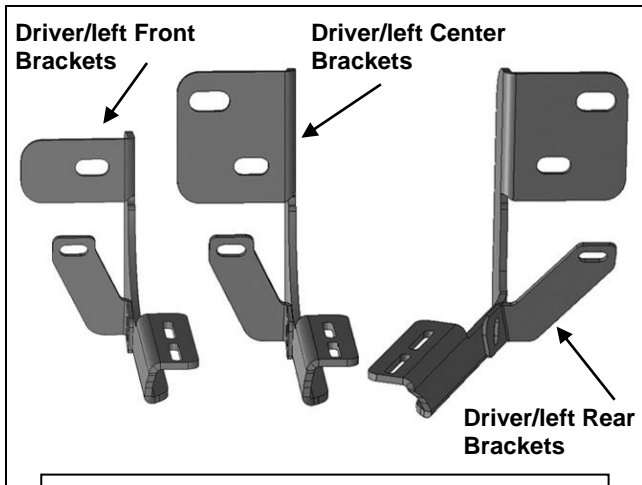

(Fig 9) Driver/left center and rear brackets

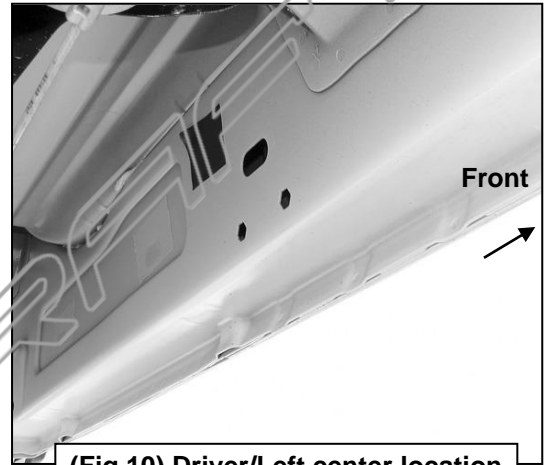

(Fig 10) Driver/Left center location



(Fig 11) Driver/Left rear location

Models without threaded insert using Bolt/Nut Plate, use:
 10mm x 35mm Hex Bolt
 10mm Lock Washer
 10mm Flat Washer

Models with threaded insert use:
 8mm x 30mm Hex Bolt
 8mm Lock Washer
 8mm Flat Washer

12mm Flat Washer
 12mm Lock Washer
 12mm Hex Nut

8mm x 25mm Hex Bolt
 (2) 8mm Flat Washers
 8mm Nylon Lock Nut

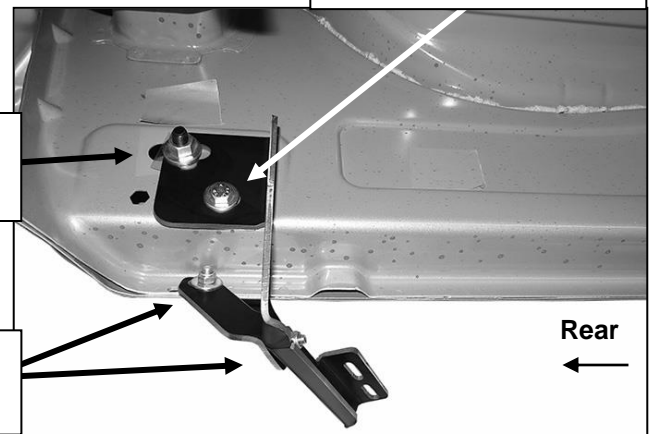

(Fig 12) Driver/Left rear bracket installation 2013-on

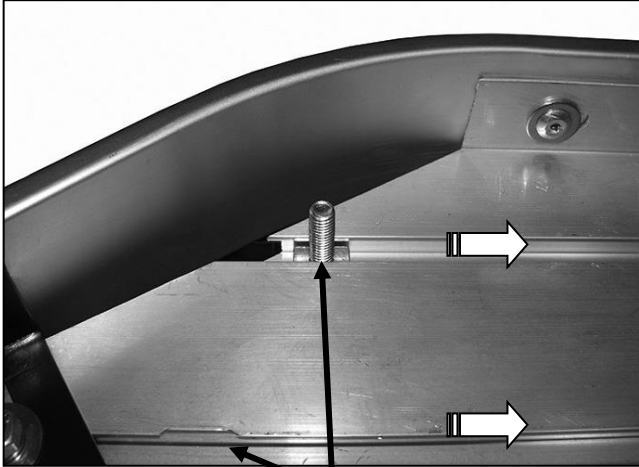

(Fig 13) Slide 6mm T-Bolts into channels

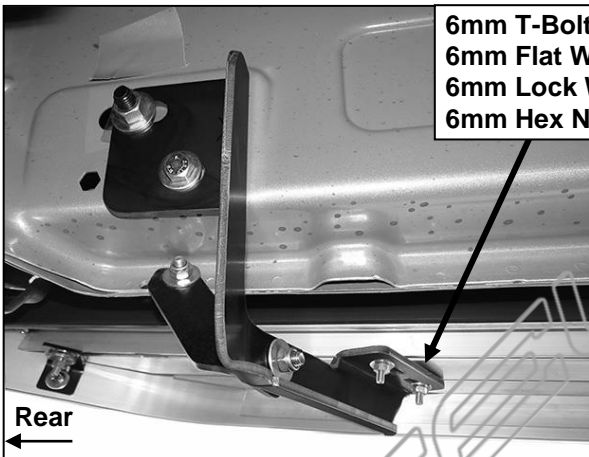

6mm T-Bolts
 6mm Flat Washers
 6mm Lock Washers
 6mm Hex Nuts

(Fig 15) Driver/left rear complete installation

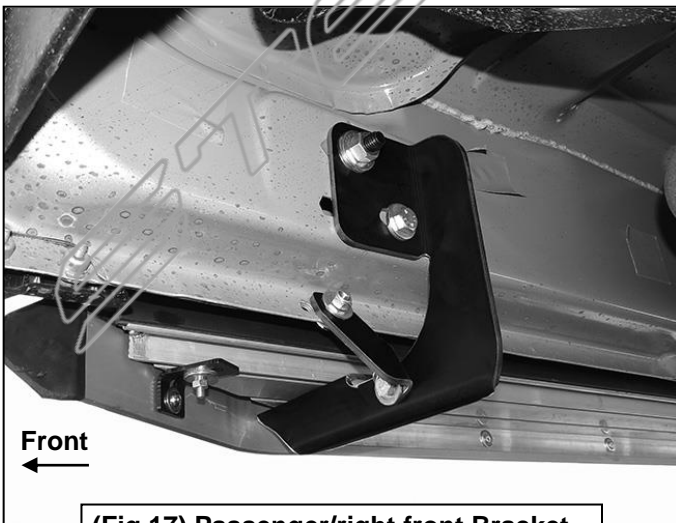

(Fig 17) Passenger/right front Bracket

2009-12 models: Mark the Support Bracket location onto back of pinch weld, (Figure 7). Drill 5/16" hole through pinch weld for all Support Brackets.



(Fig 14) Driver/left center and rear installation

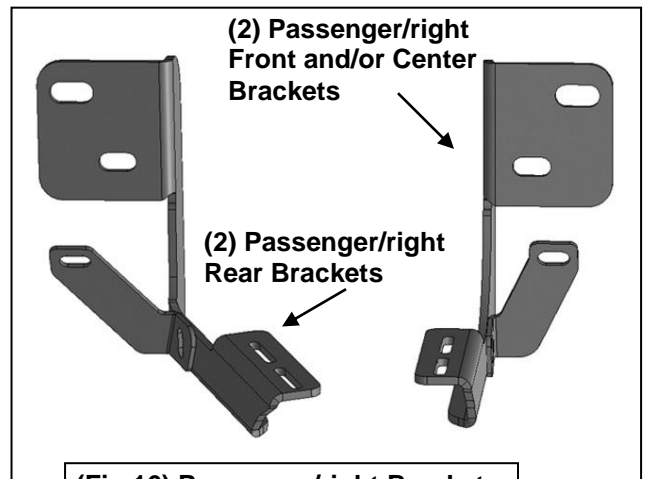

(Fig 16) Passenger/right Brackets

2009-12 models only: Do not mark or drill holes for Support Brackets until after Running Board has been installed, properly adjusted and Mounting Bracket to Bolt Plate hardware fully tightened.