

**STEELCRAFT FRONT RUNNER GRILLE GUARD
2020-24 TRANSIT VAN (FULL SIZE-2WD)**

PARTS LIST:

1	Front Runner Grille Guard Center	6	12mm Hex Nuts
1	Driver/Left Modular Wing	2	8-1.25mm x 40mm Hex Bolts
1	Passenger/Right Modular Wing	8	8-1.25mm x 30mm Hex Bolts
1	Driver/Left Frame Mounting Bracket	18	8mm x 24mm OD x 2mm Flat Washers
1	Passenger/Right Frame Mounting Bracket	2	8mm Lock Washers
1	Support Bracket	8	8-1.25mm Nylon Lock Nuts
2	Tube Spacers	2	6-1.0mm x 20mm Button Head Bolts
6	12-1.75mm x 35mm Hex Bolts	2	6mm x 18mm OD x 1.6mm Flat Washers
2	12mm x 32mm OD x 3mm Large Flat Washers	2	6mm Lock Washers
12	12mm x 24mm OD x 2.5mm STD Flat Washers	3	ST6x20mm Phillips Head Screws
6	12mm Lock Washers	1	4mm Wrench

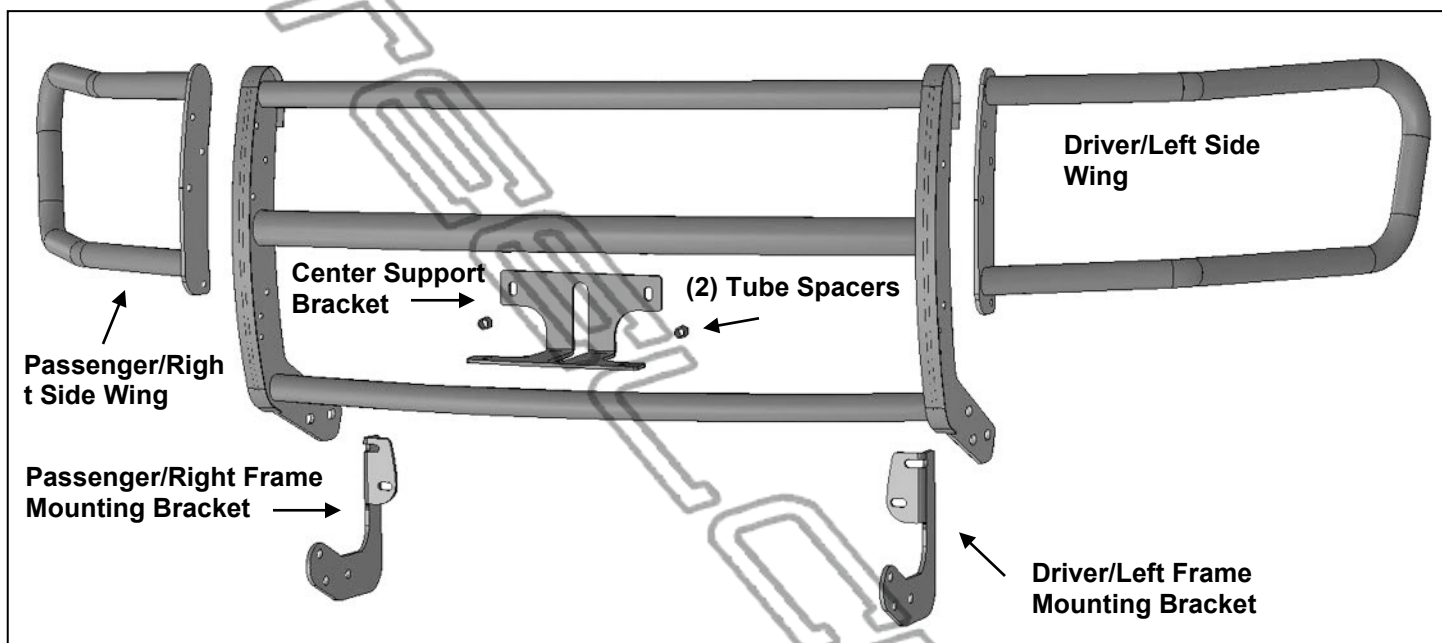

PROCEDURE:

REMOVE CONTENTS FROM BOX. VERIFY ALL PARTS ARE PRESENT. READ INSTRUCTIONS CAREFULLY BEFORE STARTING INSTALLATION. ASSISTANCE IS RECOMMENDED. CUTTING IS REQUIRED.

1. Start installation under the front bumper. Remove all of the factory hardware attaching the plastic splash guard to the bottom of the bumper, **(Figure 1)**. **NOTE:** Pay close attention to type of fasteners and location for easier reinstallation. Move splash guard to a clean stable surface.
2. From under the front of the vehicle, remove the (2) inner factory hex bolts attaching the driver/left side bumper bracket to the end of the frame, **(Figure 2)**. Select the driver/left Frame Mounting Bracket, **(Figure 3)**. Reuse (1) factory hex bolt to attach the Mounting Bracket to the top hole in the back of the bumper bracket. Leave loose at this time. Select (1) 12mm x 32mm Large Flat Washer, **(Figures 3 & 4)**. Use the Washer as a spacer on the bottom mounting hole, between the Mounting Bracket and the bumper bracket. Insert the factory hex bolt through the Mounting Bracket, Flat Washer and into the bumper bracket. Do not fully tighten hardware at this time.
3. Repeat **Step 2** to install the passenger/right Frame Mounting Bracket.
4. Next, remove the front license plate and license plate bracket if equipped, **(Figure 5)**. **IMPORTANT:** License plate bracket may be attached with rivets. Carefully drill out the center of the rivet. Do not enlarge the holes in the bumper.
5. Remove the (2) plastic plugs and hex bolts from the center of the bumper, **(Figure 6)**. Select the (2) Tube Spacers, **(Figure 7)**. Insert the Spacers into the recess in the bumper, **(Figure 8)**.

STEELCRAFT FRONT RUNNER GRILLE GUARD 2020-24 TRANSIT VAN (FULL SIZE-2WD)

6. Select the Front Support Bracket, **(Figure 9)**. Hold the Bracket in position over the Tube Spacers. Insert (2) 8mm x 40mm Hex Bolts, (2) 8mm Lock Washers and (2) 8mm Flat Washers through the Bracket, Tube Spacers and into the bumper, **(Figures 10 & 11)**. Leave loose at this time.
7. With assistance, place the Grille Guard up to the outside of the Frame Brackets. Attach the Grille Guard to the Brackets with (6) 12mm x 35mm Hex Bolts, (12) 12mm x 24mm STD Flat Washers, (6) 12mm Lock Washers and (6) 12mm Hex Nuts, **(Figures 12 & 13)**. Do not tighten hardware at this time.
8. Line up the bottom of the Support Bracket with the threaded inserts in the bottom of the crossbar. Attach the Bracket to the crossbar with (2) 6mm x 20mm Button Head Bolts, (2) 6mm Lock Washers and (2) 6mm Flat Washers, **(Figures 14 & 15)**. Snug but do not fully tighten hardware at this time.
9. Next, select the driver/left outer Wing. Attach the Wing to the center Grille Guard with (4) 8mm x 30mm Hex Bolts, (8) 8mm Flat washers and (4) 8mm Nylon Lock Nuts, **(Figure 16)**. Tighten wing hardware at this time. Repeat to attach the passenger side wing to the grille guard.
10. Align and adjust the Grille Guard and fully tighten all hardware at this time.
11. Hold the plastic splash guard up to the bottom of the Mounting Brackets, **(Figure 17)**. Trace the location of the Brackets onto the inside of the plastic cover. Use a sharp knife or hacksaw blade to cut out the sections from the cover. Reinstall the splash guard using the factory hardware.
12. Reinstall the license plate bracket over the Support Bracket. On models with bracket held on with rivets, use the included (3) ST6x20mm Screws to reattach the license plate bracket.
13. Do periodic inspections to the installation to make sure that all hardware is secure and tight.

To protect your investment, wax this product after installing. Regular waxing is recommended to add a protective layer over the finish. Do not use any type of polish or wax that may contain abrasives that could damage the finish.

For stainless steel: Aluminum polish may be used to polish small scratches and scuffs on the finish. Mild soap may be used also to clean the Grille Guard.

For gloss black finishes: Mild soap may be used to clean the Grille Guard.



(Fig 1) Remove plastic splash guard (arrow)

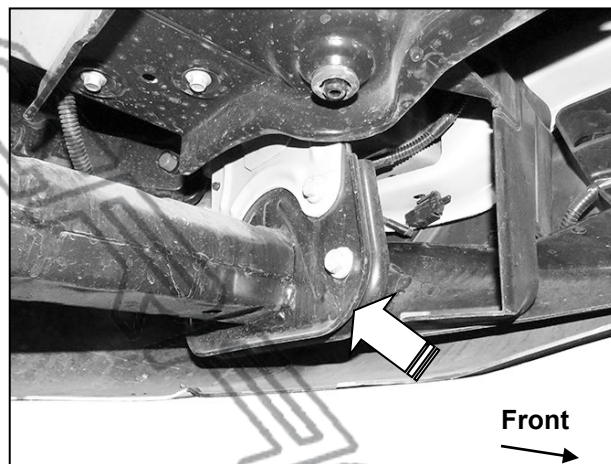

(Fig 2) Locate bumper bracket (driver/left side pictured from below and behind bumper). Remove (2) inner bumper bracket bolts (arrow)

**STEELCRAFT FRONT RUNNER GRILLE GUARD
2020-24 TRANSIT VAN (FULL SIZE-2WD)**

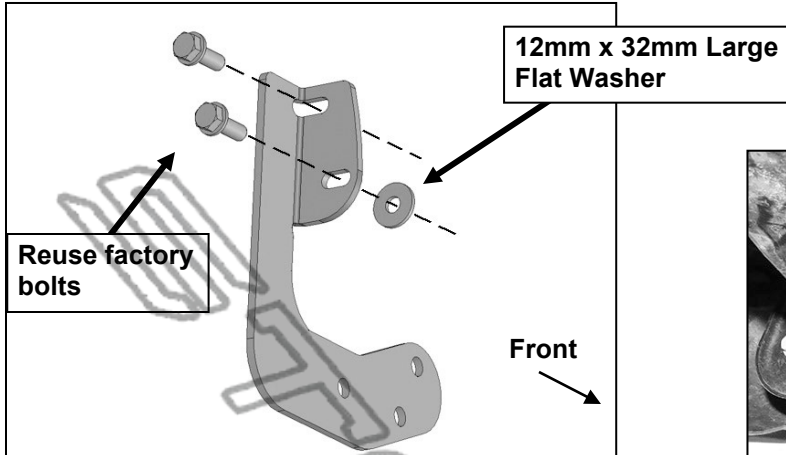

(Fig 3) Reuse factory hex bolts to attach driver/left Bracket to back of bumper bracket. Insert (1) 12mm x 32mm Large Flat Washer between Mounting Bracket and bumper bracket

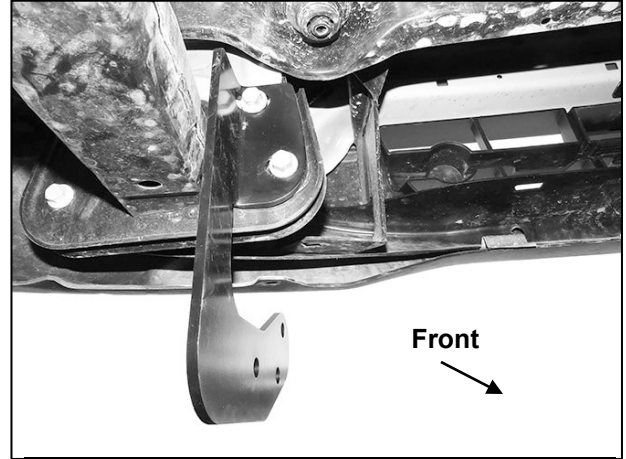

(Fig 4) Driver/left Mounting Bracket installed



(Fig 5) Remove license plate and bracket

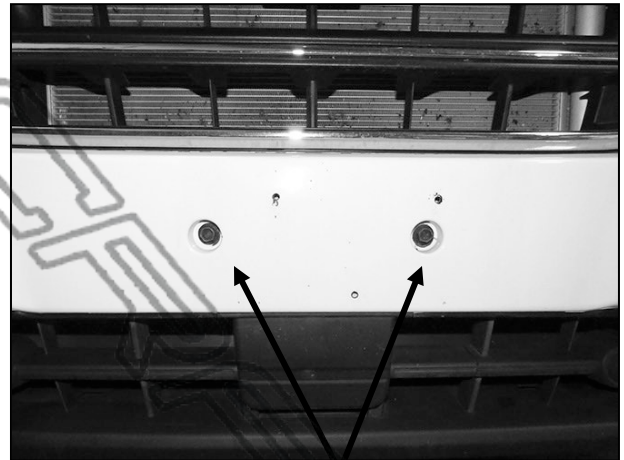

(Fig 6) Remove (2) plastic plugs and hex bolts



**STEELCRAFT FRONT RUNNER GRILLE GUARD
2020-24 TRANSIT VAN (FULL SIZE-2WD)**

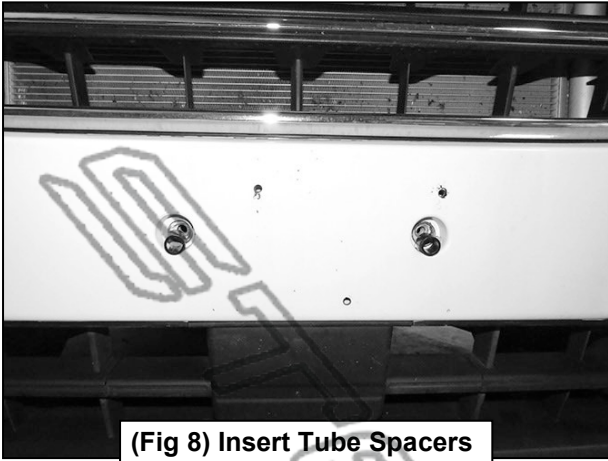

(Fig 8) Insert Tube Spacers into recesses in bumper

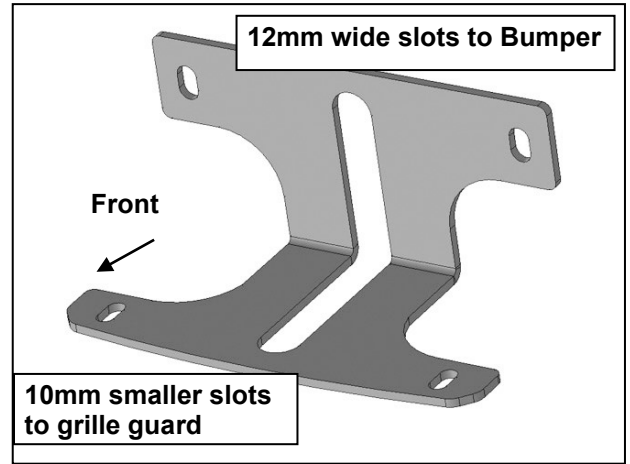

(Fig 9) Support Bracket

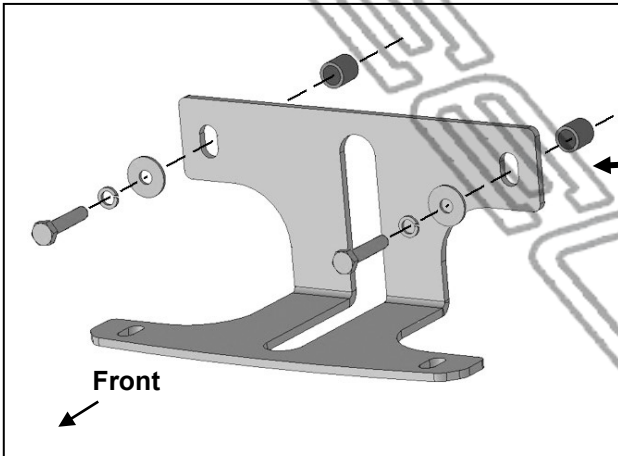

- (2) 8mm x 40mm Hex Bolts
 - (2) 8mm Lock Washers
 - (2) 8mm Flat Washers
- Insert Bolts through Bracket, Tube Spacers then into bumper

(Fig 10) Attach Support Bracket to front of bumper

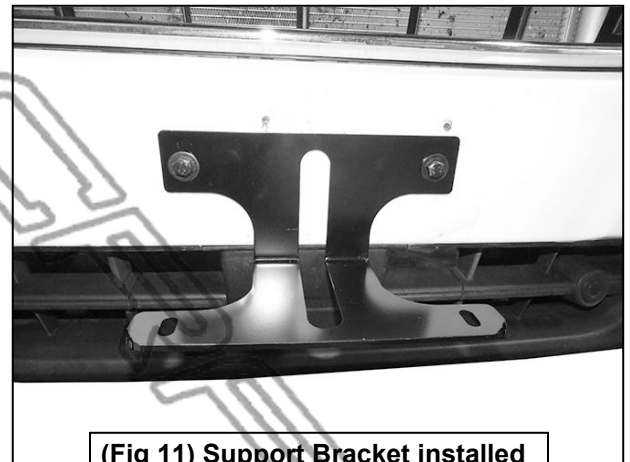

(Fig 11) Support Bracket installed

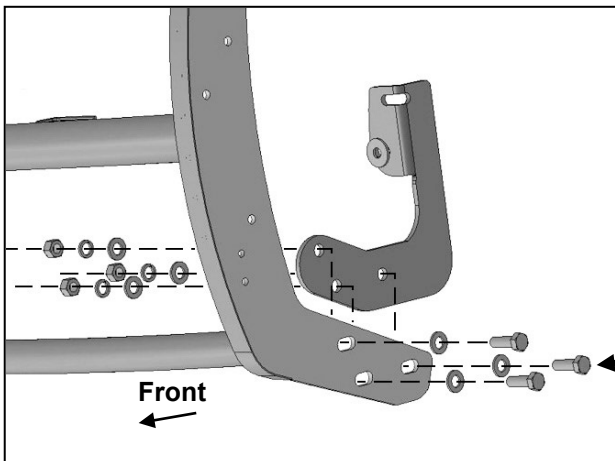

- (3) 12mm x 35mm Hex Bolts
- (6) 12mm x 24mm STD Flat Washers
- (3) 12mm Lock Washers
- (3) 12mm Hex Nuts

(Fig 12) Attach Grille Guard to outside of Brackets

**STEELCRAFT FRONT RUNNER GRILLE GUARD
2020-24 TRANSIT VAN (FULL SIZE-2WD)**

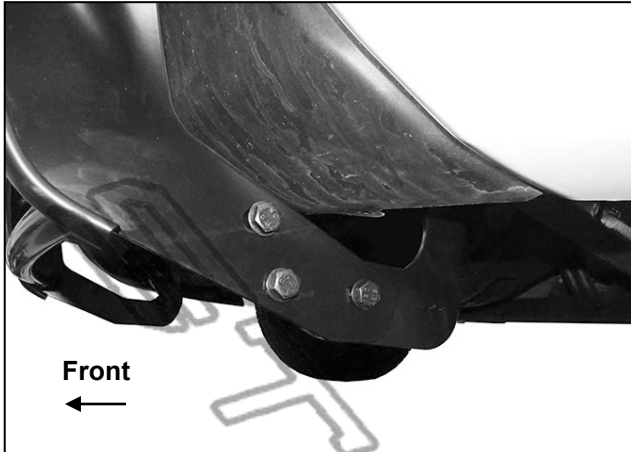

(Fig 13) Driver/left side of Grille Guard attached

- (2) 6mm x 20mm Button Head Bolts
- (2) 6mm Lock Washers
- (2) 6mm Flat Washers

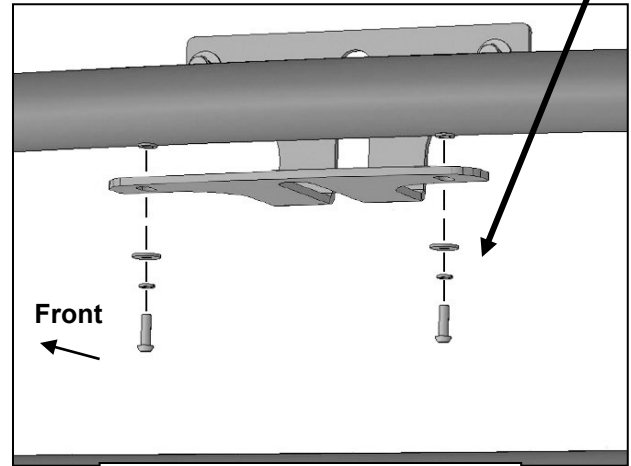

(Fig 14) Attach Support Bracket to bottom of Grille Guard

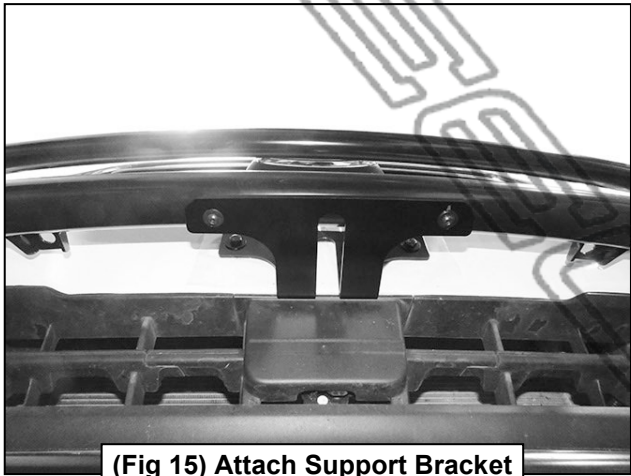

(Fig 15) Attach Support Bracket to bottom of Grille Guard

- (4) 8mm x 30mm Hex Bolts
- (8) 8mm Flat Washers
- (4) 8mm Nylon Lock Nuts

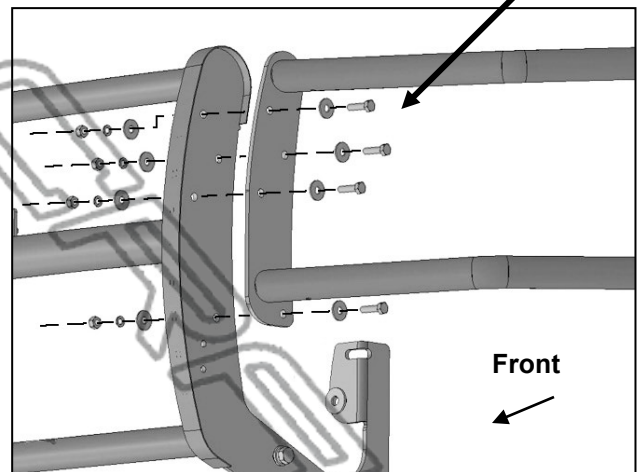

(Fig 16) Attach driver/left outer Wing to Grille Guard

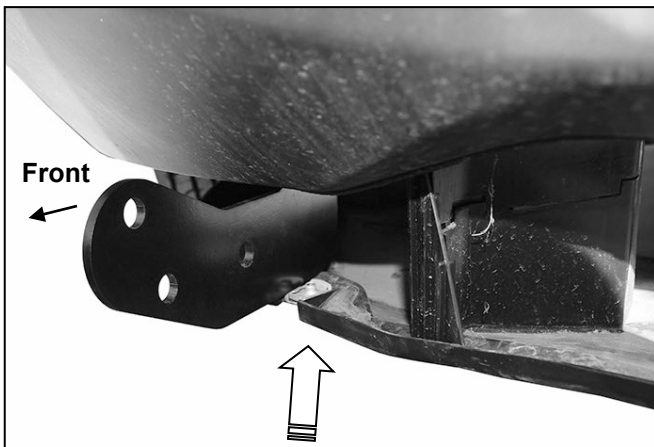

Fig 17) Hold the splash guard up to the bottom of the Brackets. Trace location of Brackets onto back of the plastic cover and cut to clear brackets