

INSTALLATION INSTRUCTIONS

GRILLE GUARD

84-01 JEEP CHEROKEE 2W / 4W

PART # 52050

PARTS LIST:

1	Grille Guard	4	10-1.50mm x 40mm Hex Head Bolts
2	Frame Brackets	4	10mm ID x 26mm OD x 3mm Flat Washers
4	12-1.75mm x 30mm Hex Head Bolts	2	Rivets
4	12mm Nylock Nuts		
8	12mm ID x 29mm OD x 3mm Flat Washers		

NOTE: On 85-96 models it may not be necessary to remove the bumper skin to gain access to the bumper bolts. The following procedure apply to all models, however there are differences in the bumpers so on early models the front bar will fit without cutting the bumper skin.

PROCEDURE:

- 1. REMOVE CONTENTS FROM BOX. VERIFY ALL PARTS ARE PRESENT. READ INSTRUCTIONS CAREFULLY BEFORE STARTING INSTALLATION.**
- 2. Bumper Removal procedure.** Remove the three bolts securing it to the frame and the two securing it to the side fender. Disconnect any wiring or hoses from the bumper and remove completely.
- 3. NOTE:** The front bar mounts between the frame and the bumper brackets, hence then bumper brackets need to slide outboard. To move the bumper bracket, the bumper skin has to be removed to gain access to the top bumper bolt. Figure 2 illustrates the bumper skin attachment and the bumper bolts. Notice there is a rivet joining the center section to the outer ones; this does not need to be removed.
4. Remove the bottom bolts shown in Figure 2 and the clip shown on top. This will expose the top bumper bolt. Loosen the bottom and top bumper bolts on both side of the frame. Re-install the bumper by inserting the mounting brackets between the frame and the bumper brackets, as shown in Figure 3.
5. To re-install the bumper with the mounting brackets, use two of the supplied bolts on each side of the front holes and the factory bolt in the rear hole. Push the bracket all the way up and tighten.
6. Once the brackets have been mounted, fasten the bumper bolts and re-install the bumper skin.
7. In order for the Grille Guard to fit properly the bumper skin needs to be trimmed. Figure 4 shows how to trim the bumper skin. Measure $1\frac{3}{4}$ " from the bottom of the hole and make a $\frac{1}{2}$ " slot.
8. Position the Grille Guard to the brackets as shown in Figure 3 and fasten using the included 12mm hardware.
9. Do periodic inspections to the installation to make sure that all hardware is secure and tight.

Remove the factory bolts in order to remove the bumper. Notice there are 5 bolts to remove.

Bumper Bracket

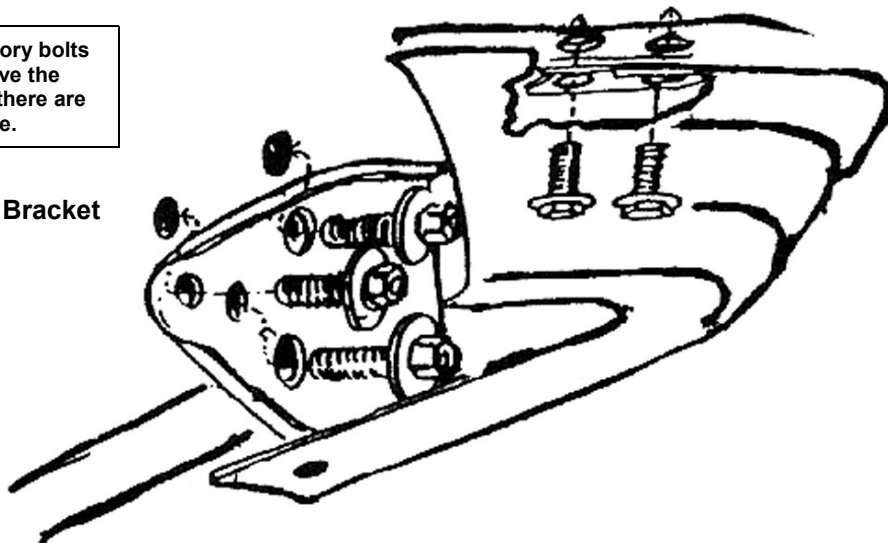

Passenger Side

Figure 1

Loosen the bumper bracket bolts and move the bumper brackets outboard

Once the bottom bolts are removed, pull the bumper skin outboard to un-hook the clip.

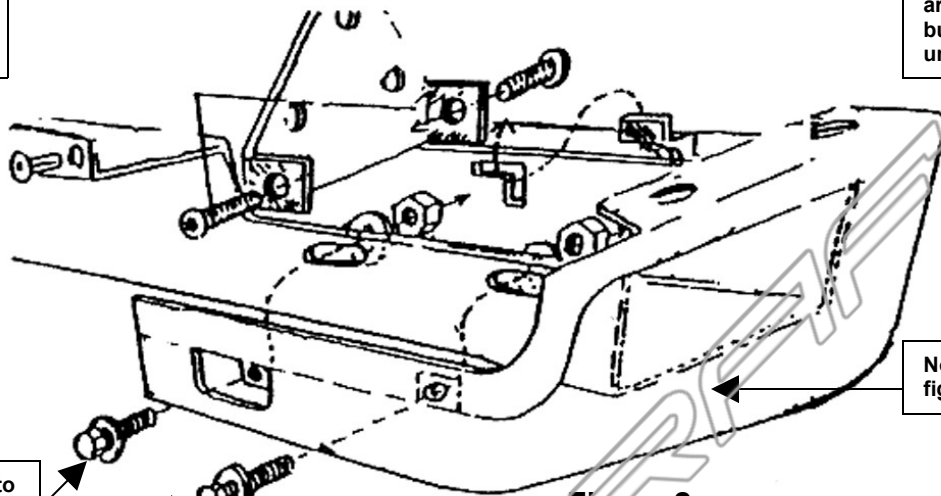

Note the bumper in this figure is faced down.

Remove these bolts to remove bumper skin.

Figure 2

Passenger Side

Mount the mounting bracket between the frame and the bumper bracket

Bumper Bracket

Factory Bolt

Frame

10mm x 40mm Hex Bolt
10mm Flat Washers

Notice the angle of the brackets faces outboard

Mounting Bracket

Grille Guard

12mm x 30mm Hex Bolts
12mm Nylock Nuts
12mm Flat Washers

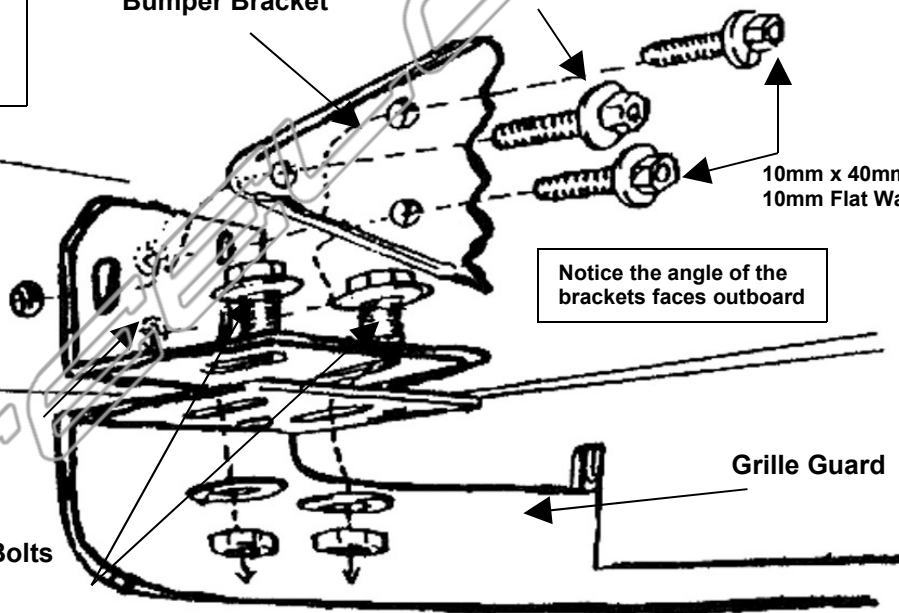

Figure 3

Passenger Side

Cut a 1/2" slot from the bottom of the hole down to 1 3/4"

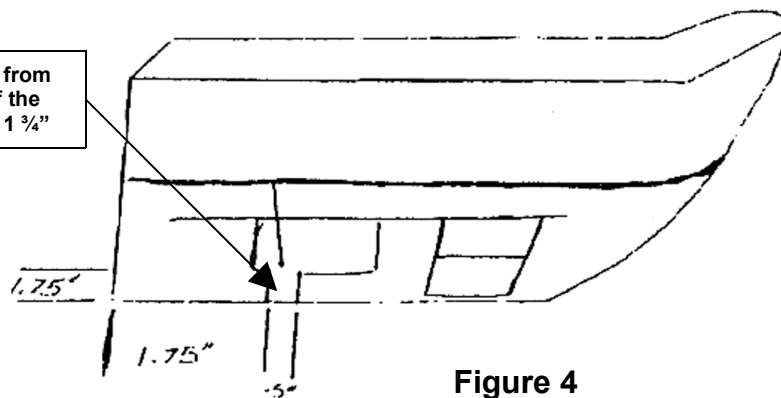

Figure 4

Passenger Side