

**HD BULL NOSE FRONT BUMPER  
2011-16 FORD SUPERDUTY F250-350**

**PARTS LIST:**

1	HD Bull Nose Front Bumper Assembly	1	Bumper Cover
1	Winch Tray Bracket Assembly	5	6mm Combo Button Head Bolts (cover)
2	3-hole Bracket Spacer Plates	1	Wrench (6mm Button Head)
2	Plastic Plugs for license plate mount	4	5mm x 20mm Button Head Bolts
18	12-1.75mm x 50mm Hex Bolts	8	5mm x 10mm x 1mm Flat Washers
36	12mm x 32mm x 3mm Flat Washers	4	5mm Nylon Lock Nuts
18	12mm Lock Washers	1	Wrench (5mm Button Head)
18	12-1.75mm Hex Nuts		

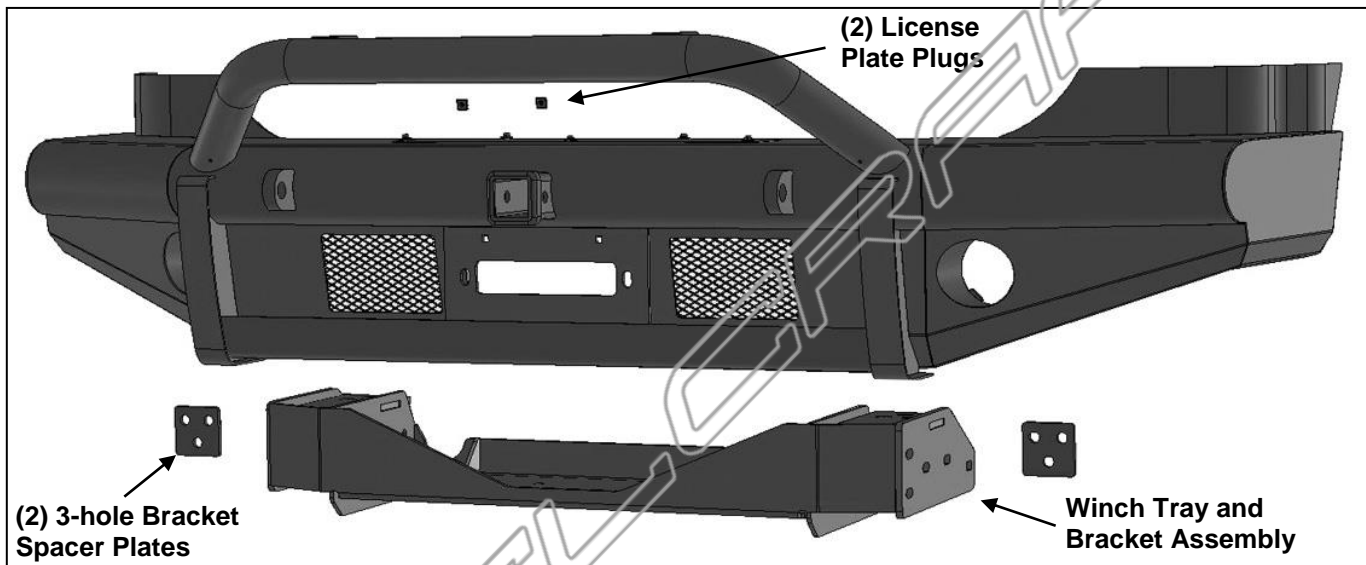

**PROCEDURE:**

**REMOVE CONTENTS FROM BOX. VERIFY ALL PARTS ARE PRESENT. READ INSTRUCTIONS CAREFULLY BEFORE STARTING INSTALLATION. BUMPER IS HEAVY, ASSISTANCE IS HIGHLY RECOMMENDED TO AVOID POSSIBLE INJURY OR DAMAGE TO THE VEHICLE.**

1. Remove the license plate and bracket. On models with factory fog lights, unplug lights. Release wiring harness from clips attached to the bumper, **(Figures 1 & 2)**. Move harness away from bumper.
2. Release the rubber air deflector from the back of the bumper. Next, remove the hardware at each end of the bumper, attaching the outer bumper supports to each side of the frame, **(Figure 2)**.
3. Place blocks or jack stands under the front bumper to support it during mounting bolt removal. Once the bumper has been safely supported, remove the (4) factory bumper bolts, **(Figure 3)**.  
**WARNING!** Assistance is required to hold the bumper in place during bolt removal to prevent the bumper from falling. Carefully slide the bumper off over the tow hooks.
4. Remove the driver side tow hook from the end of the frame, **(Figure 4)**. Next, remove the (4) factory hex nuts, lower frame extension and double bolt plates from the end of the frame, **(Figures 1, 4 & 5)**. Repeat this Step to remove the passenger side tow hook and lower frame extension.
5. Next, select the Winch Tray Bracket Assembly. Slide the assembly over the ends of the frame and line up the slots in the assembly with the holes in the inner and outer sides of the frame. Attach the assembly to both ends of the frame with the included (6) 12mm x 50mm Hex Bolts, (12) 12mm Flat Washers, (6) 12mm Lock Washers and (6) 12mm Hex Nuts, **(Figures 6—8)**. Leave hardware loose.
6. Line up the (3) holes in the top of the driver side of the assembly with the top of the frame, **(Figure 9)**. Select (1) 3-hole Spacer Plate. Attach the Spacer Plate to the top of the assembly and frame with (3) 12mm Hex Bolts, (6) 12mm Flat Washers, (3) 12mm Lock Washers and (3) 12mm Hex Nuts, **(Figures 10 & 11)**. Leave hardware loose. Repeat to attach the Spacer Plate to the top of the passenger side.
7. If installing winch, attach winch to Winch Tray at this time. Winch must be installed before Bumper is placed in position against Brackets. Next, attach winch cable guide to Bumper assembly. Follow manufacturer's instructions to properly wire the winch to the electrical system.

## HD BULL NOSE FRONT BUMPER 2011-16 FORD SUPERDUTY F250-350

8. With assistance, carefully position the Bumper Assembly up to the ends of the Winch Tray. Temporarily support the weight of the Bumper. **WARNING:** To avoid possible injury or damage to the vehicle, do not proceed until the bumper is fully and safely supported. Models with winch, check for clearance before fully installing Bumper assembly.
9. Line up the (3) holes in the driver side of the Bumper with the (3) holes in the Winch Tray. Attach the Bumper to the Winch Tray with the included (3) 12mm Hex Bolts, (6) 12mm Flat Washers, (3) 12mm Lock Washers and (3) 12mm Hex Nuts, **(Figures 12 & 13)**. Do not fully tighten hardware at this time. Repeat to attach the passenger side of the Bumper to the Winch Tray.
10. Level and adjust the bumper and fully tighten all 12mm hardware to 65-70ft-lbs.
11. **Models with factory fog lights:**
  - a. Use a flat blade screwdriver or pliers to pop off the round outer metal clip over each of the hex nuts attaching the plastic light bracket to the back of the factory bumper. **(Figure 14)**. Remove the hex nuts and the light assembly, **(Figure 15)**.
  - b. Next, use a flat blade screwdriver to pop up the center pin on the (2) fasteners attaching the top of the light to the bracket, **(Figure 15)**.
  - c. Remove the adjustment screw, spring and plastic nut from the bottom of the light.
  - d. Slide the light into place between the mounting tabs on the HD Bumper. Use the included (2) 5mm Button Head Screws, (4) 5mm Flat Washers and (2) 5mm Nylon Lock Nuts to attach the top of the light to the mounting tabs, **(Figure 16)**. Attach the plastic nut to the lower bent tab on the Bumper. Insert the screw through the tab on the light, the spring (between light and tab on bumper), and into the plastic nut. Adjust the light as needed.
  - e. Repeat to install the remaining fog light.
  - f. Reattach the factory wiring harness to both lights.
12. Use the included (2) push-in plastic nuts to attach the front license plate, (if required), to the (2) holes in the front bumper, **(Figure 17)**. Remove winch access cover if desired, **(Figure 18)**.
13. Do periodic inspections to the installation to make sure that all hardware is secure and tight.

**To protect your investment**, wax this product after installing. Regular waxing is recommended to add a protective layer over the finish. Do not use any type of polish or wax that may contain abrasives that could damage the finish. Mild soap may be used to clean the HD Front Bumper assembly.

### Driver Side Installation Pictured



**(Fig 1) Driver side lower frame extension and fog light wire harness pictured from behind bumper**

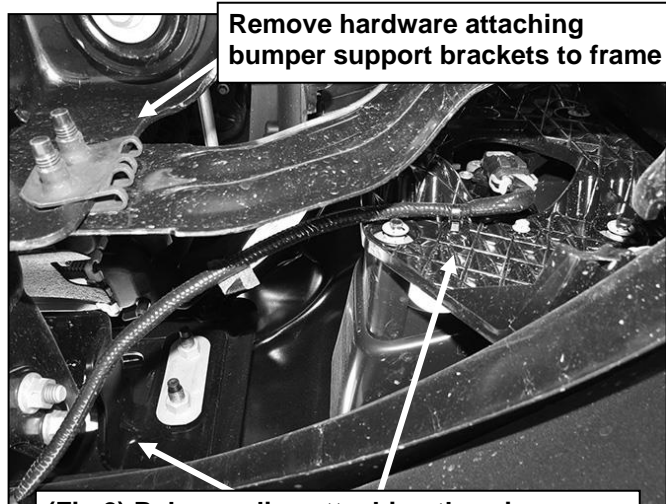

**(Fig 2) Release clips attaching the wire harness for fog lights if equipped. Passenger side pictured from behind bumper**

Driver Side Installation Pictured

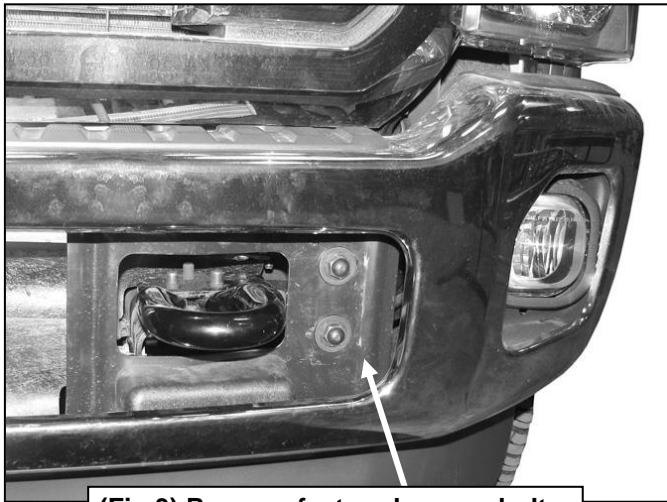

(Fig 3) Remove factory bumper bolts

**WARNING!** Do not remove bumper bolts unless the bumper is properly supported on blocks or stands or the bumper may fall.

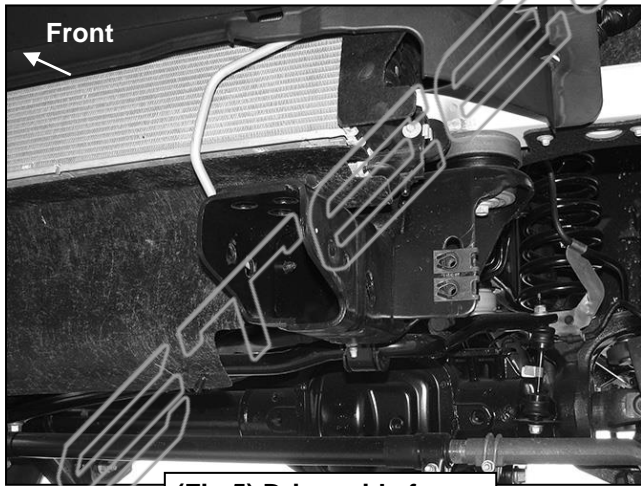
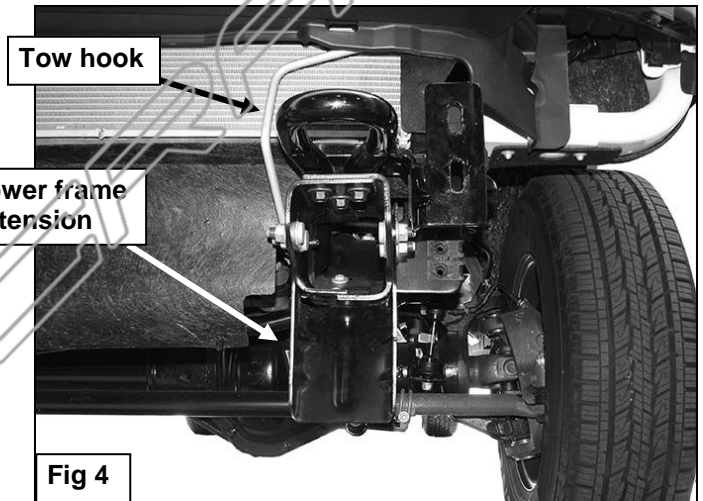

(Fig 5) Driver side frame

- (3) 12mm x 50mm Hex Bolts
- (6) 12mm Flat Washers
- (3) 12mm Lock Washers
- (3) 12mm Hex Nuts

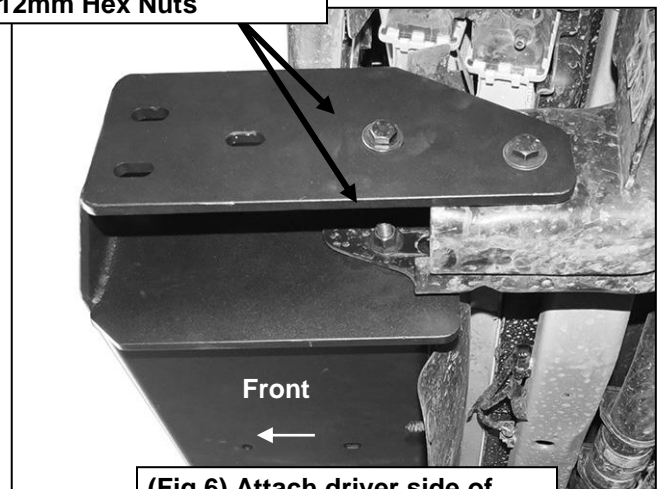

(Fig 6) Attach driver side of Winch Tray assembly to frame

**HD BULL NOSE FRONT BUMPER  
2011-16 FORD SUPERDUTY F250-350**

**Driver Side Installation Pictured**

**WARNING!** Do not crawl under bumper unless the bumper is properly supported on blocks or stands or the bumper may fall.

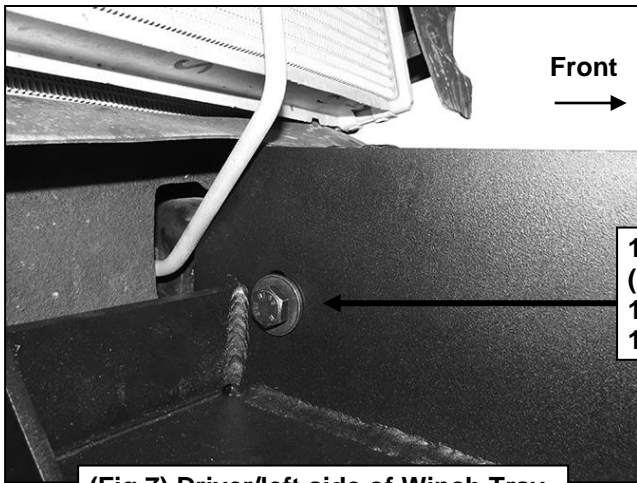

(Fig 7) Driver/left side of Winch Tray

- 12mm x 50mm Hex Bolt
- (2) 12mm Flat Washers
- 12mm Lock Washer
- 12mm Hex Nut

- 12mm x 50mm Hex Bolt
- (2) 12mm Flat Washers
- 12mm Lock Washer
- 12mm Hex Nut

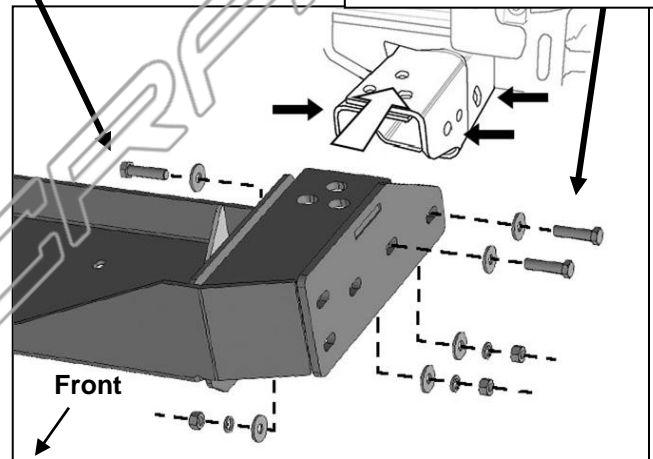

(Fig 8) Attach driver side of Winch Tray to frame

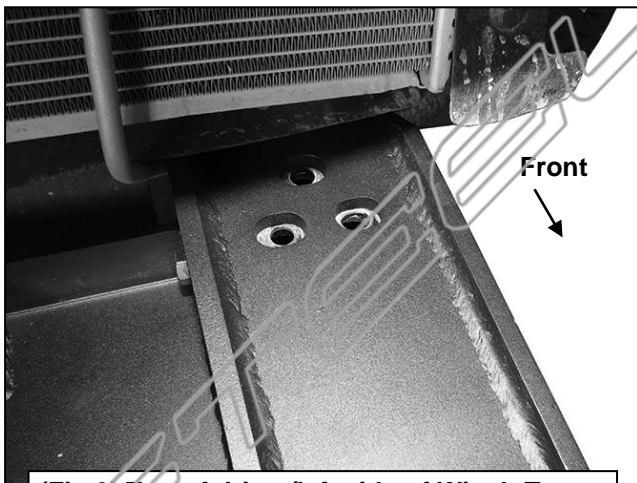

(Fig 9) Top of driver/left side of Winch Tray

- (3) 12mm x 50mm Hex Bolts
- (6) 12mm Flat Washers
- (3) 12mm Lock Washers
- (3) 12mm Hex Nuts

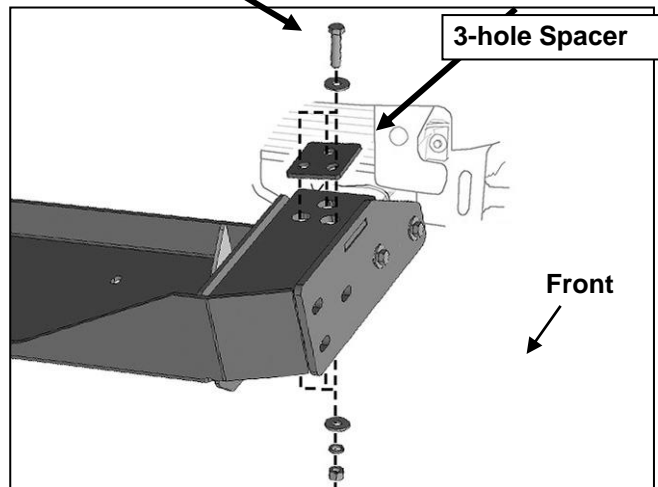

(Fig 10) Attach 3-hole Spacer to top of Hitch Tray

Driver Side Installation Pictured

- (3) 12mm x 50mm Hex Bolts
- (6) 12mm Flat Washers
- (3) 12mm Lock Washers
- (3) 12mm Hex Nuts

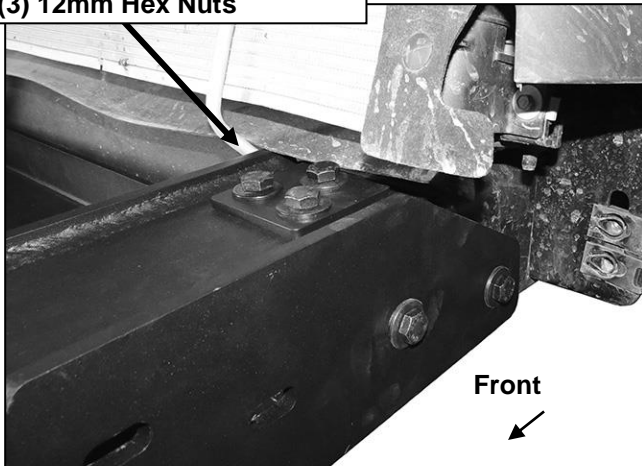

(Fig 11) Attach 3-hole Spacer to top of Hitch Tray

**WARNING!** Do not crawl under bumper unless the bumper is properly supported on blocks or stands or the bumper may fall.

- (3) 12mm x 50mm Hex Bolts
- (6) 12mm Flat Washers
- (3) 12mm Lock Washers
- (3) 12mm Hex Nuts

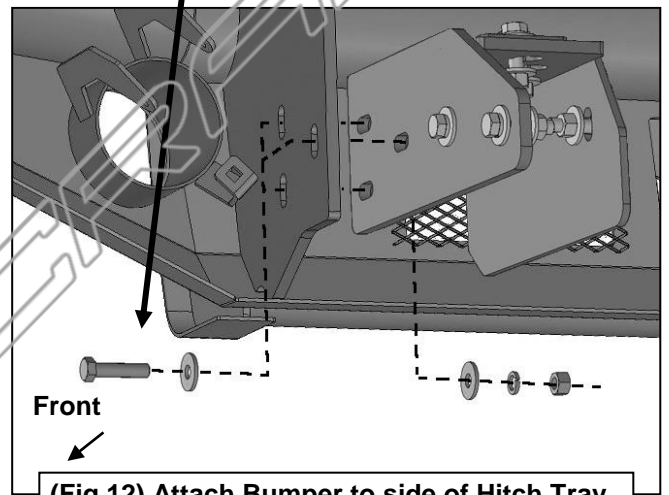

(Fig 12) Attach Bumper to side of Hitch Tray

- (3) 12mm x 50mm Hex Bolts
- (6) 12mm Flat Washers
- (3) 12mm Lock Washers
- (3) 12mm Hex Nuts



(Fig 13) Attach Bumper to side of Hitch Tray

Pry off tin clips covering hex nuts

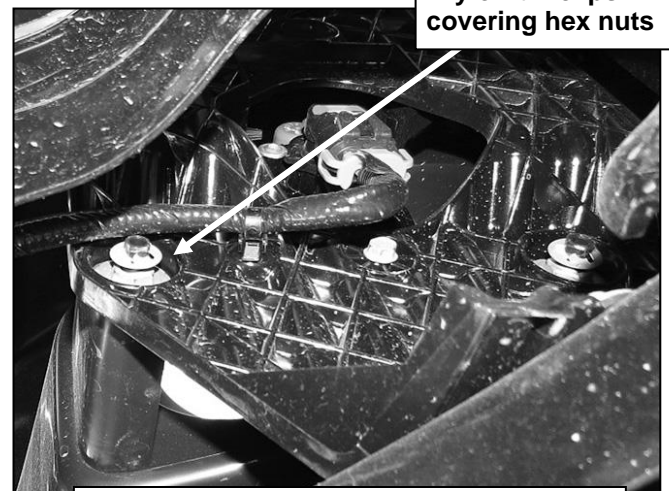

(Fig 14) Remove hex nuts to remove complete fog light assembly with bracket

**HD BULL NOSE FRONT BUMPER  
2011-16 FORD SUPERDUTY F250-350**

Carefully pry up center pin to release clip

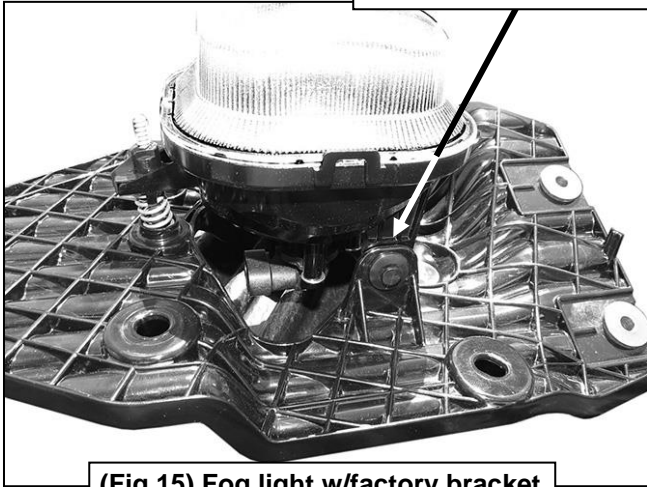

**(Fig 15) Fog light w/factory bracket**

- (2) 5mm Screws
- (4) 5mm Flat Washers
- (2) 5mm Nylon Lock Nuts

Reuse  
Factory screw  
Spring  
Plastic nut

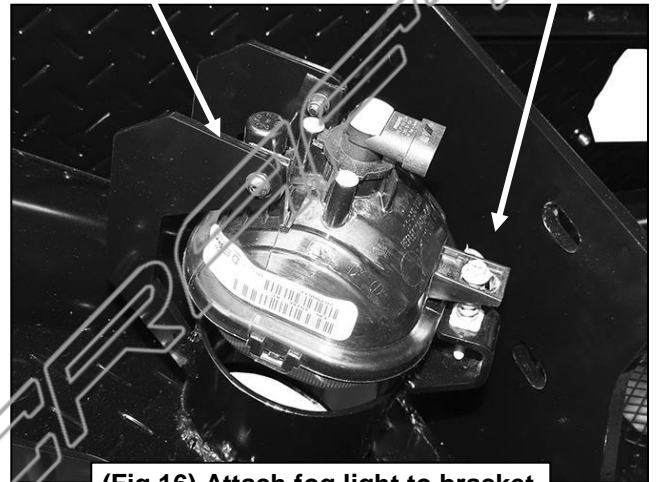

**(Fig 16) Attach fog light to bracket**

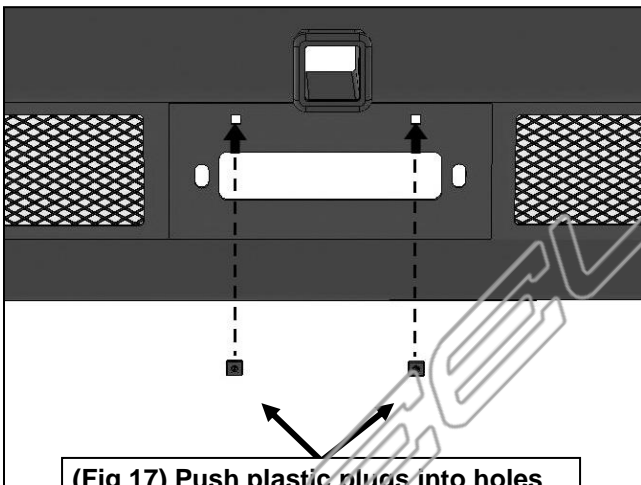

**(Fig 17) Push plastic plugs into holes in Bumper for license plate if required**

Remove cover over winch if desired

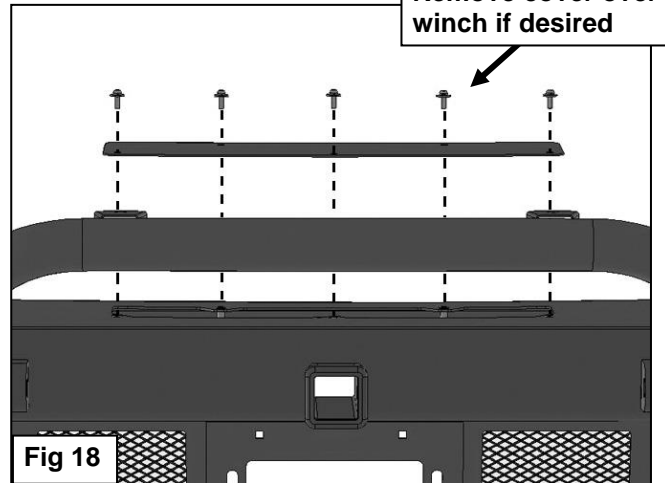

**Fig 18**

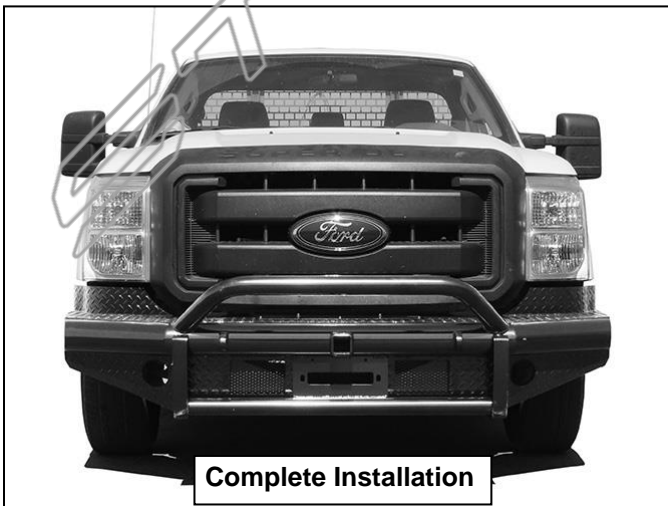

**Complete Installation**