

**STEELCRAFT ELEVATION FRONT BUMPER  
1999-2007 FORD SUPERDUTY**

**PARTS LIST:**

1	Elevation Front Bumper	32	12mm x 32mm x 3mm Flat Washers
1	Driver/left Side Frame Bracket	4	12mm x 24mm x 2.5mm Flat Washers
1	Passenger/right Side Frame Bracket	22	12mm Lock Washers
1	Driver/left Side Support Bracket	22	12mm Hex Nuts
1	Passenger/right Side Support Bracket	2	12mm Plastic Retainers
1	Driver/left Side Fill Panel ( <b>ONLY</b> for <b>05-07</b> models)	2	12mm x 50mm Double Bolt Plates
1	Passenger/right Side Fill Panel ( <b>ONLY</b> for <b>05-07</b> models)	4	12mm x 50mm Single Bolt Plates
2	License Plate Plugs	14	12mm x 50mm Hex Bolts
1	Driver/left Side Inner Fog Light Bracket	8	6mm x 20mm Hex Bolts
1	Passenger/right Side Inner Fog Light Bracket	16	6mm x 12mm x 1.6mm Flat Washers
1	Driver/left Side Outer Fog Light Bracket	8	6mm Nylon Lock Nuts
1	Passenger/right Side Outer Fog Light Bracket	4	5mm x 20mm Button Head Bolts
2	8mm x 25mm Hex Bolts	8	5mm x 10mm x 1mm Flat Washers
4	8mm x 24mm x 2mm Flat Washers	4	5mm Nylon Lock Nuts
2	8mm Lock Washers	1	Allen Wrench (5mm)
2	8mm Hex Nuts		

**STEELCRAFT ELEVATION FRONT BUMPER  
1999-2007 FORD SUPERDUTY**

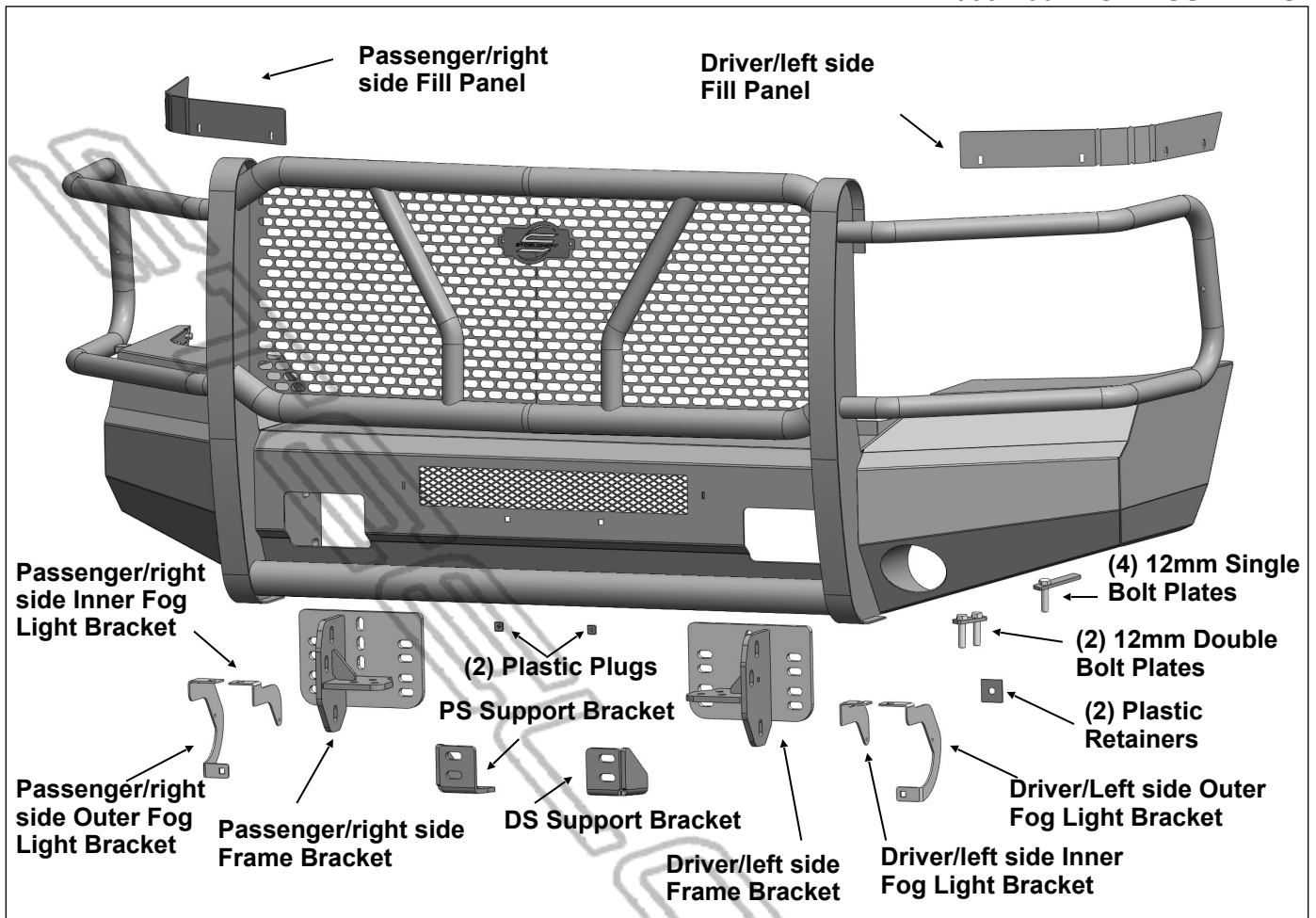

**PROCEDURE:**

**REMOVE CONTENTS FROM BOX. VERIFY ALL PARTS ARE PRESENT. READ INSTRUCTIONS CAREFULLY BEFORE STARTING INSTALLATION. ASSISTANCE IS HIGHLY RECOMMENDED TO AVOID POSSIBLE INJURY OR DAMAGE TO THE VEHICLE.**

1. Remove the license plate. On models with factory fog lights, unplug both lights. Release wiring harness from the clips attached to the back of the bumper, **(Figure 1)**. Move harness away from bumper.
2. Next, remove the (3) factory bolts, per side, to remove the lower cross member if equipped, **(Figures 2A & 2B)**. Remove the factory bolts on the outer bumper supports attaching the outer ends of the bumper to the sides of the frame, **(Figure 3)**.
3. Place blocks or jack stands under the front bumper to support it during mounting bolt removal. Once the bumper has been safely supported, remove the (4) factory bumper bolts, **(Figures 4 & 5)**. **WARNING!** Assistance is required to hold the bumper in place during bolt removal to prevent the bumper from falling. Carefully slide the bumper off, over the tow hooks.
4. Remove the driver/left side tow hook by loosening the 3 bolts attaching it to the frame, **(Figure 6)**. Select the Driver/left side Support Bracket, **(Figure 7)**. Insert (2) 12mm Single Bolt Plates into the bottom slots on the Bracket. Next, insert (1) 12mm Double Bolt Plate in through the remaining slots in the Bracket. Thread (1) 12mm Plastic Retainer onto the Bolt Plate tight against the Bracket, **(Figure 8)**. **NOTE:** The Plastic Retainer is used to help prevent the Double Bolt Plate from falling and to aid in Frame Bracket installation.
5. Slide the Support Bracket assembly into the channel of the frame, **(Figure 9)**. Insert the (2) Single Bolt Plates in through (2) factory tow hook holes on the bottom of the frame. Secure the Bracket to the bottom of the frame using (2) 12mm x 32mm Flat Washers, (2) 12mm Lock Washers and (2) 12mm Hex Nuts, **(Figure 10)**. Do not tighten hardware.

## STEELCRAFT ELEVATION FRONT BUMPER 1999-2007 FORD SUPERDUTY

6. Select the Driver/left side Frame Bracket. **On 99-04 models**, use the illustration on **Figure 11** to help determine the correct mounting slots for Frame Bracket installation. **On 05-07 models**, use the illustration on **Figure 12** to help determine the correct mounting slots for frame Bracket installation.
7. Attach the Driver/left side Frame Bracket to the Double Bolt Plate on the Support Bracket with (2) 12mm x 24mm Flat Washers, (2) 12mm Lock Washers and (2) 12mm Hex Nuts, (**Figure 13**). Secure the Frame Bracket to the front of the frame using (4) 12mm x 50mm Hex Bolts, (8) 12mm x 32mm Flat Washers, (4) 12mm Lock Washers and (4) 12mm Hex Nuts, (**Figure 14**). Do not tighten hardware.
8. Next, reuse the factory tow hook hardware to reinstall the driver/left side tow hook onto the bottom mounting plate of the Frame Bracket, (**Figure 15**).
9. Repeat **Steps 4 — 8** for passenger side Support Bracket, Frame Bracket, and tow hook installation.
10. Determine if truck is equipped with factory fog lights, otherwise skip to **step 11**.
  - a. Remove the fog light assemblies from the back of the OE Bumper, (**Figure 16**).
  - b. Disassemble the fog light from the OE bracket by removing the plastic pins and adjustment screw.
  - c. Attach the Driver Side Inner Fog Light Bracket and the DS Outer Fog Light Bracket to the bumper by using (1) 8mm x 25mm Hex Bolts, (2) 8mm Flat Washers, (1) 8mm Lock Washer and (1) 8mm Hex Nut (**Figure 17**).
  - d. Attach the DS fog light to the inner and outer brackets by using (2) 5mm Button Head Bolts, (4) 5mm Flat Washers and (2) 5mm Nylon Lock Nuts, (**Figure 18**). Secure the bottom of fog light by re-using the factory fog light adjusting screw. Do not fully tighten hardware at this time.
  - e. Repeat for Passenger Side installation.
11. (**99-04 models skip to step 12**) **On 05-07 models ONLY**, select the Driver/left side Fill Panel. Use (4) 6mm Hex Bolts, (8) 6mm Flat Washers and (4) 6mm Nylon Lock Nuts to attach the Fill Panel to the Bumper, (**Figure 19**). **NOTE:** The Fill Panel is used to fill in the gap between the top of the Bumper and bottom of the headlight. Repeat this Step for passenger side Fill Panel installation.
12. With assistance, carefully position the Bumper Assembly up to the outside of the Frame Brackets. **WARNING:** To avoid possible injury or damage to the vehicle, do not proceed until the bumper is fully and safely supported.
13. Attach the Bumper to the Brackets with the included (6) 12mm x 50mm Hex Bolts, (12) 12mm Flat Washers, (6) 12mm Lock Washers and (6) 12mm Hex Nuts, (**Figure 20**). Do not tighten hardware.
14. Level and adjust Bumper, then tighten all hardware. Re-attach the OE crossmember.
15. Use the provided (2) Plastic Plugs to attach the license plate to the front of the Bumper, (**Figure 21**).
16. Do periodic inspections to the installation to make sure that all hardware is secure and tight.

**To protect your investment**, do not use any type of polish or wax that may contain abrasives that could damage the finish. Mild soap may be used to clean the Bumper Assembly.

### Driver/left Side Installation Pictured



**STEELCRAFT ELEVATION FRONT BUMPER  
1999-2007 FORD SUPERDUTY**

**(Fig 3) Remove factory bolt attaching outer bumper bracket to frame (passenger side shown)**

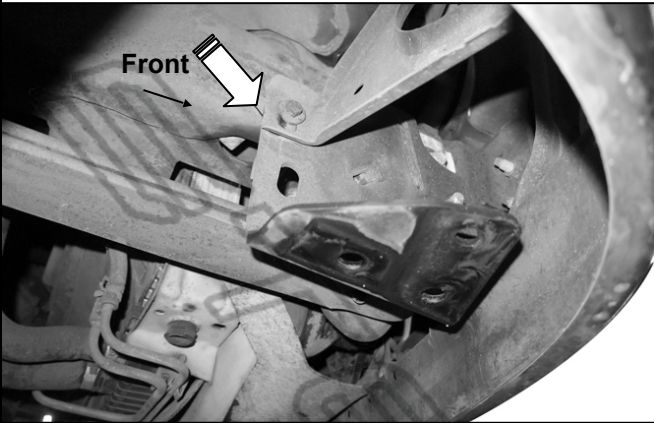

**(Fig 2A) Models equipped with lower cross member must remove factory bolts, 3 per side.**

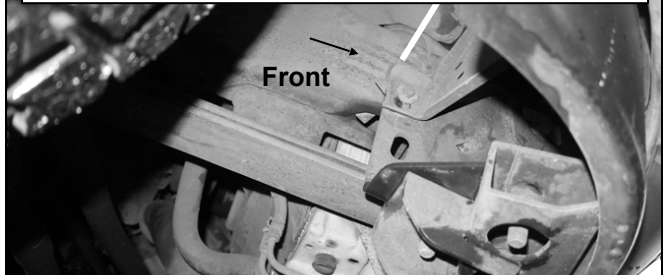

**WARNING!** Do not remove bumper bolts unless the bumper is properly supported on blocks or stands or the bumper may fall.

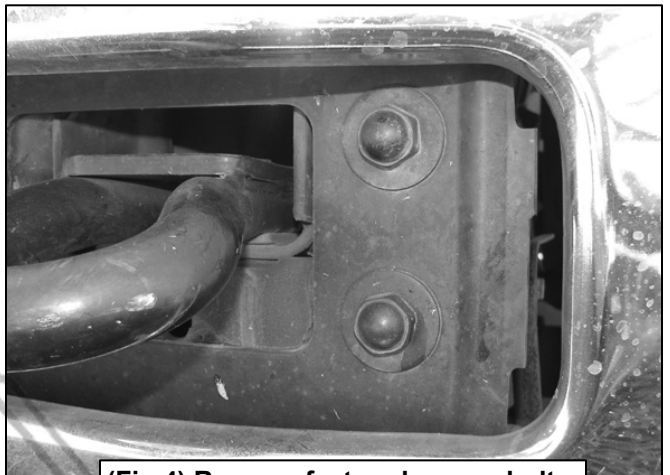

**(Fig 4) Remove factory bumper bolts**

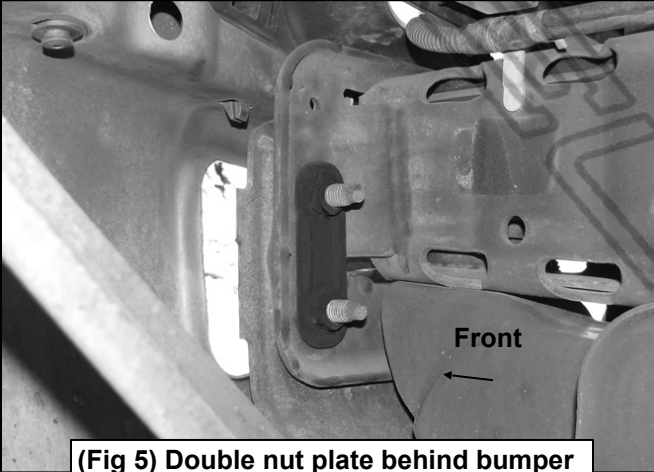

**(Fig 5) Double nut plate behind bumper**

**Driver/left Side Installation Pictured**



**(Fig 6) Remove factory tow hook**

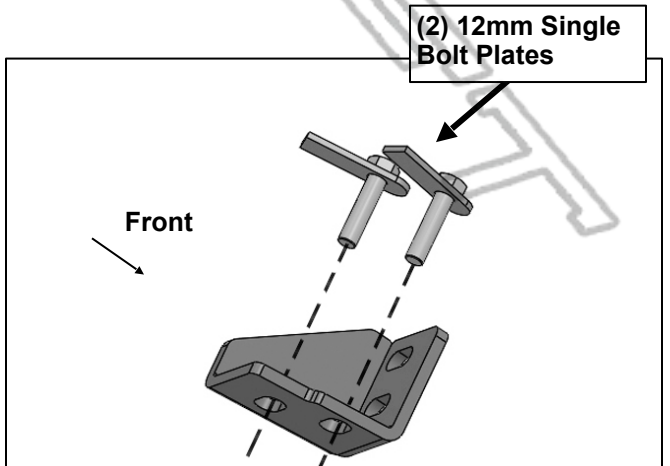

**(Fig 7) Insert (2) Single Bolt Plates into the bottom of the Driver/left side Support Bracket**

**STEELCRAFT ELEVATION FRONT BUMPER  
1999-2007 FORD SUPERDUTY**

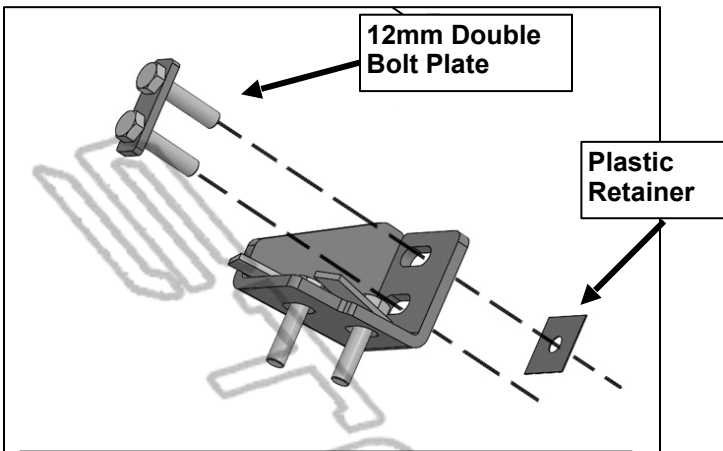

**(Fig 8) Driver/left side Support Bracket with (1) Double Bolt Plate and Plastic Retainer**

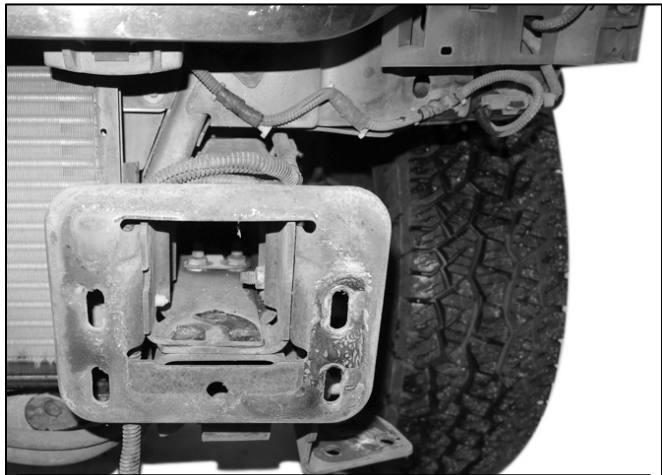

**(Fig 9) Driver/left side frame mounting location**

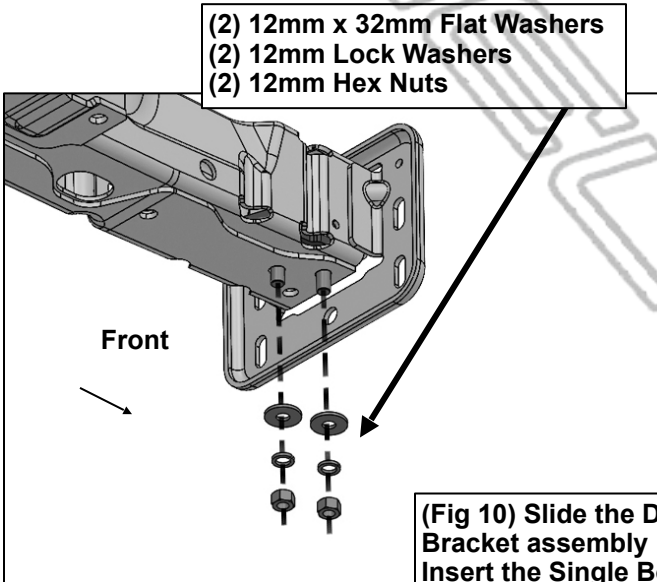

**(Fig 10) Slide the Driver/left side Support Bracket assembly inside the frame channel. Insert the Single Bolt Plates in through the bottom tow hook holes on the frame.**

**Driver/left Side Installation Pictured**

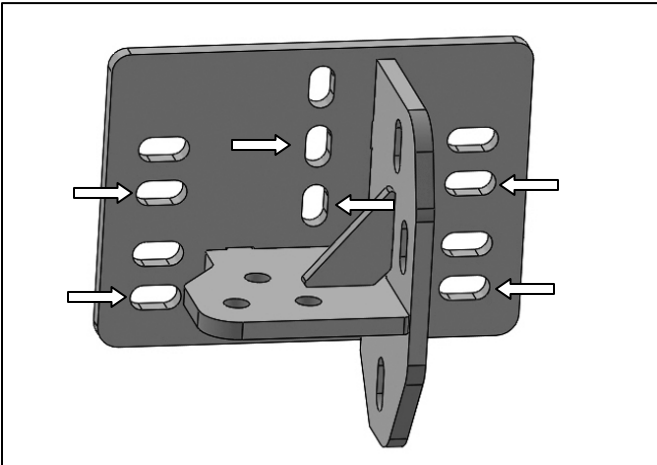

**(Fig 11) On 99-04 models, use the lowest set of mounting slots in the illustration above, (arrows)**

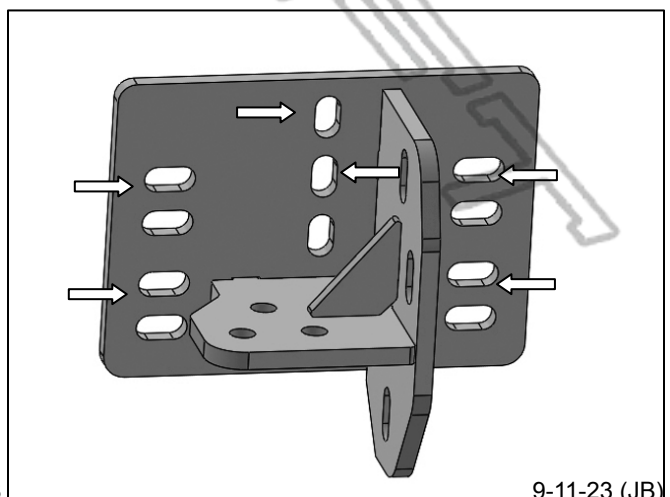

**STEELCRAFT ELEVATION FRONT BUMPER  
1999-2007 FORD SUPERDUTY**

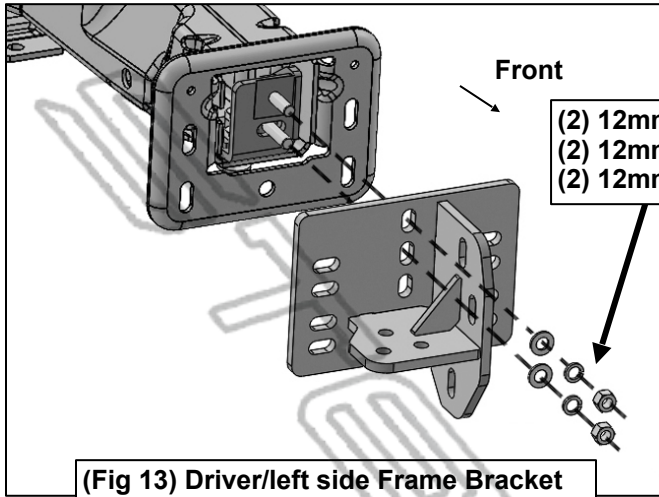

(Fig 12) On 05-07 models, use the highest set of mounting slots in the illustration above, (arrows)

- (2) 12mm x 24mm Flat Washers
- (2) 12mm Lock Washers
- (2) 12mm Hex Nuts

(Fig 13) Driver/left side Frame Bracket attached to the Support Bracket

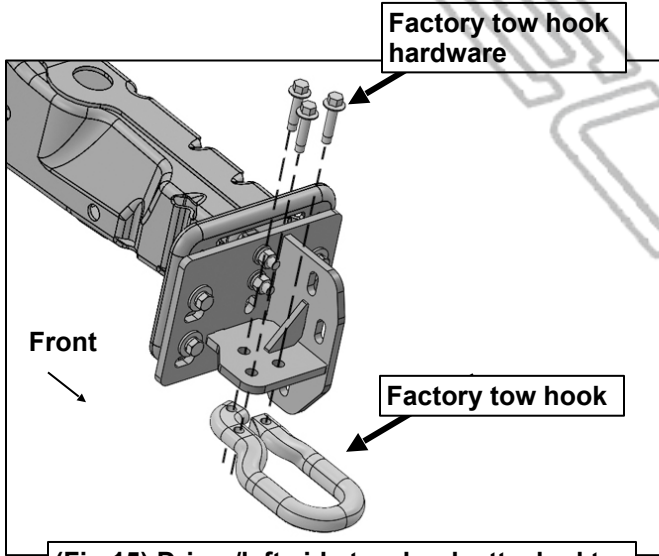

Factory tow hook hardware

Factory tow hook

(Fig 15) Driver/left side tow hook attached to the bottom plate on the Frame Bracket

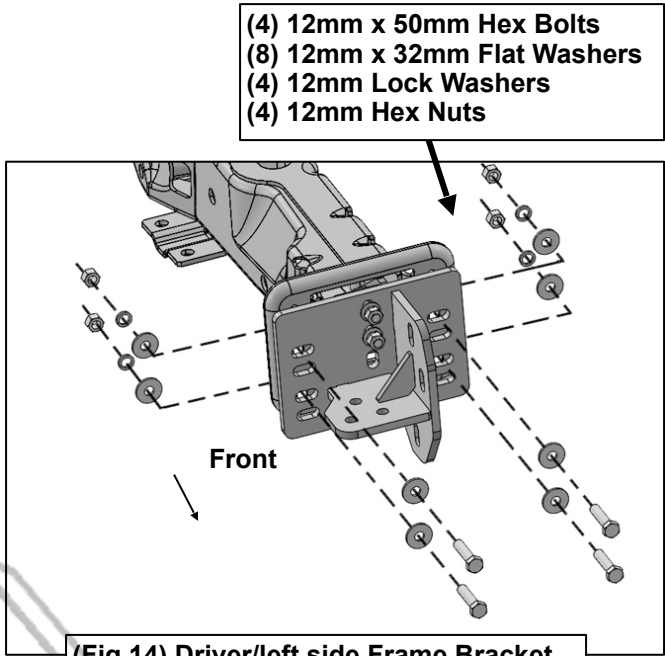

- (4) 12mm x 50mm Hex Bolts
- (8) 12mm x 32mm Flat Washers
- (4) 12mm Lock Washers
- (4) 12mm Hex Nuts

(Fig 14) Driver/left side Frame Bracket attached to the frame

**Driver/left Side Installation Pictured**

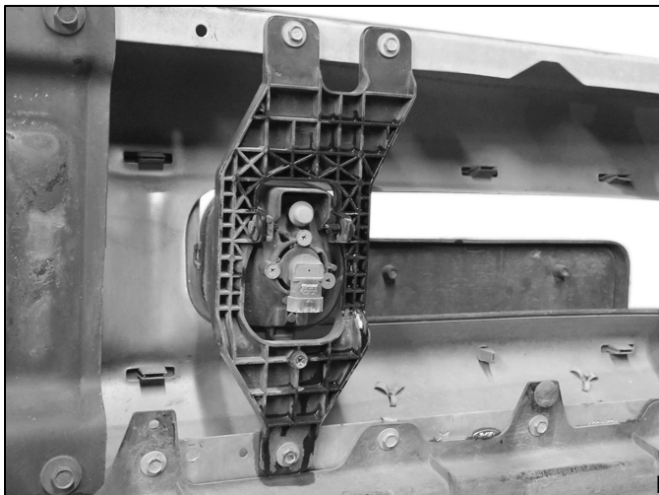

**STEELCRAFT ELEVATION FRONT BUMPER  
1999-2007 FORD SUPERDUTY**

- (2) 8mm Hex Bolts
- (4) 8mm Flat Washers
- (2) 8mm Nylon Lock Nuts

**(Fig 16) Remove the fog light from the back of the OE bumper (Driver side Pictured)**

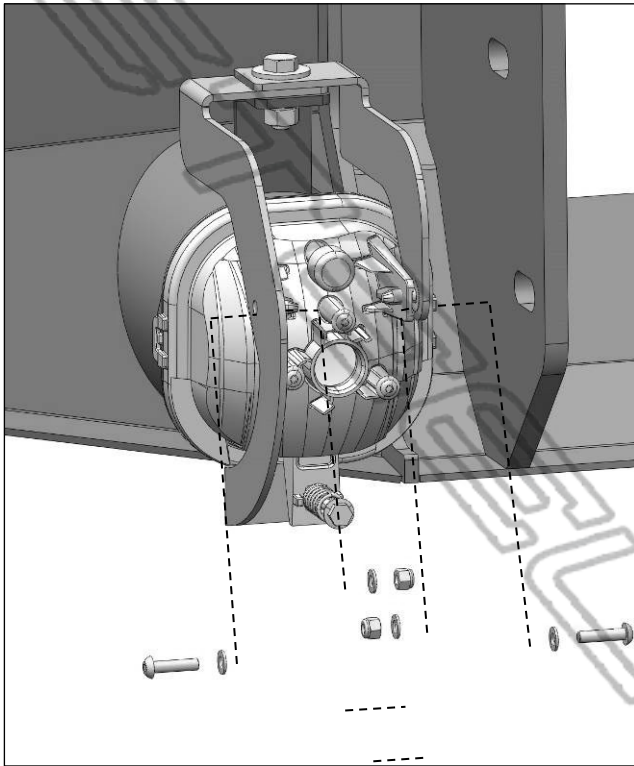

- (2) 5mm Button Head Bolts
- (4) 5mm Flat Washers
- (2) 5mm Nylon Lock Nuts

**(Fig 18) Driver/left side Fog light attached to the brackets on the back of the Bumper**

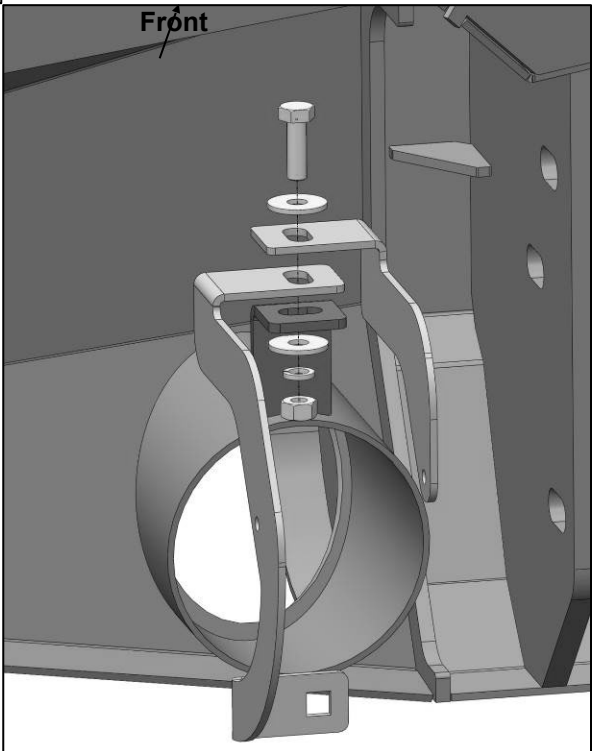

**(Fig 17) Driver/left side Fog light attached to the mount on the back of the Bumper**

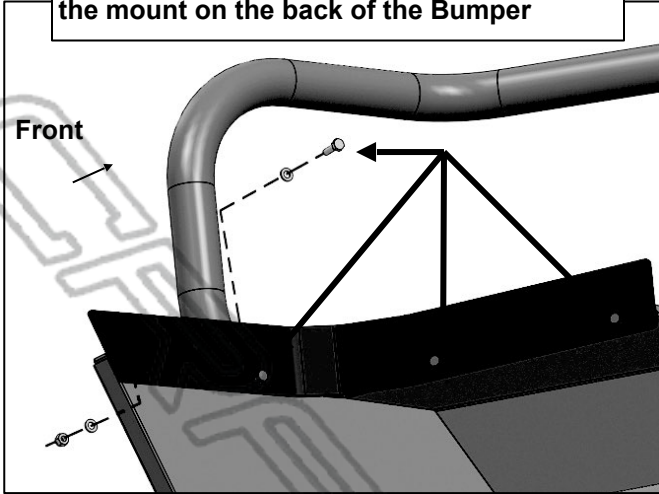

- (4) 6mm Hex Bolts
- (8) 6mm Flat Washers
- (4) 6mm Nylon Lock Nuts

**(Fig 19) Driver/left side Fill Panel attached to the Bumper (ONLY 05-07 models)**

**Driver/left Side Installation Pictured**

**STEELCRAFT ELEVATION FRONT BUMPER  
1999-2007 FORD SUPERDUTY**

- (3) 12mm x 50mm Hex Bolts
- (6) 12mm x 32mm Flat Washers
- (3) 12mm Lock Washers
- (3) 12mm Hex Nuts

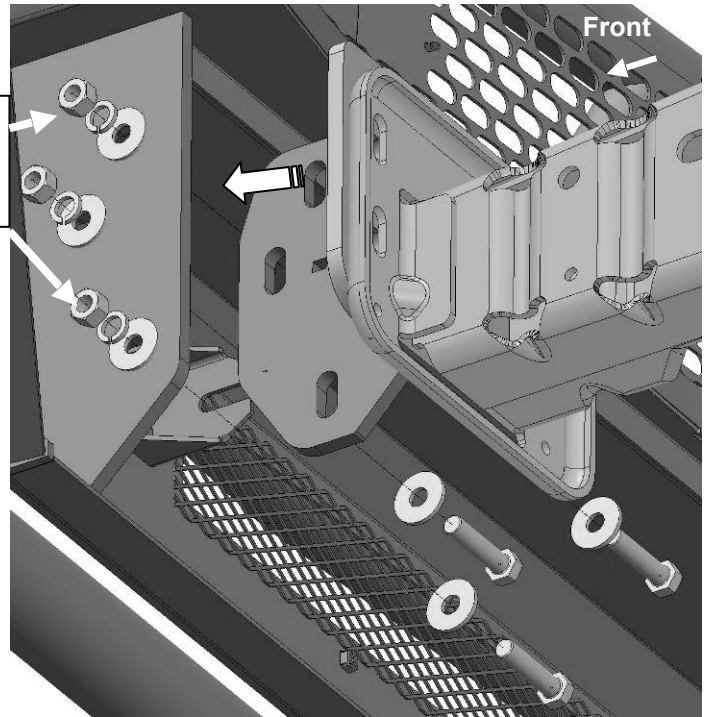

**WARNING!** Do not crawl under bumper unless the bumper is properly supported on blocks or stands or the bumper may fall.

**(Fig 20) Bumper attached to the outside of the Driver/left side Frame Bracket illustrated**

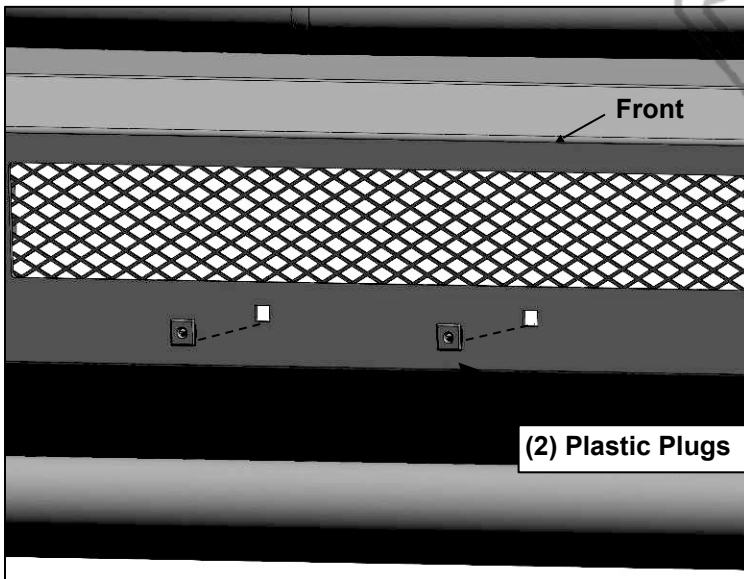

**(Fig 21) Attach License Plate to front of Bumper**