

**ELEVATION FRONT BUMPER
2017-20 FORD RAPTOR**

PARTS LIST:

1	Elevation Front Bumper	4	12mm Lock Washers
1	Driver/Left Mounting Bracket	12	12mm Nylon Lock Nuts
1	Passenger/Right Mounting Bracket	4	12mm Double Nut Plates
1	Driver/Left Support Bracket	2	8mm x 20mm Hex Bolts
1	Passenger/Right Support Bracket	2	8mm x 24mm OD x 2mm Flat Washers
1	ACC Plastic Cover	2	8mm x 18mm OD x 1.6mm Flat Washers
1	ACC Relocation Bracket	2	8mm Nylon Lock Nuts
1	ACC Sensor Bracket	7	6mm x 25mm Button Head Bolts
2	License Plate Plugs	10	6mm x 18mm OD x 1.6mm Flat Washers
4	Spacer Plates	7	6mm Lock Washers
2	12mm x 170mm Hex Bolts	7	6mm Hex Nuts
14	12mm x 45mm Hex Bolts	1	4mm Hex Wrench
28	12mm x 37mm OD x 3mm Flat Washers		

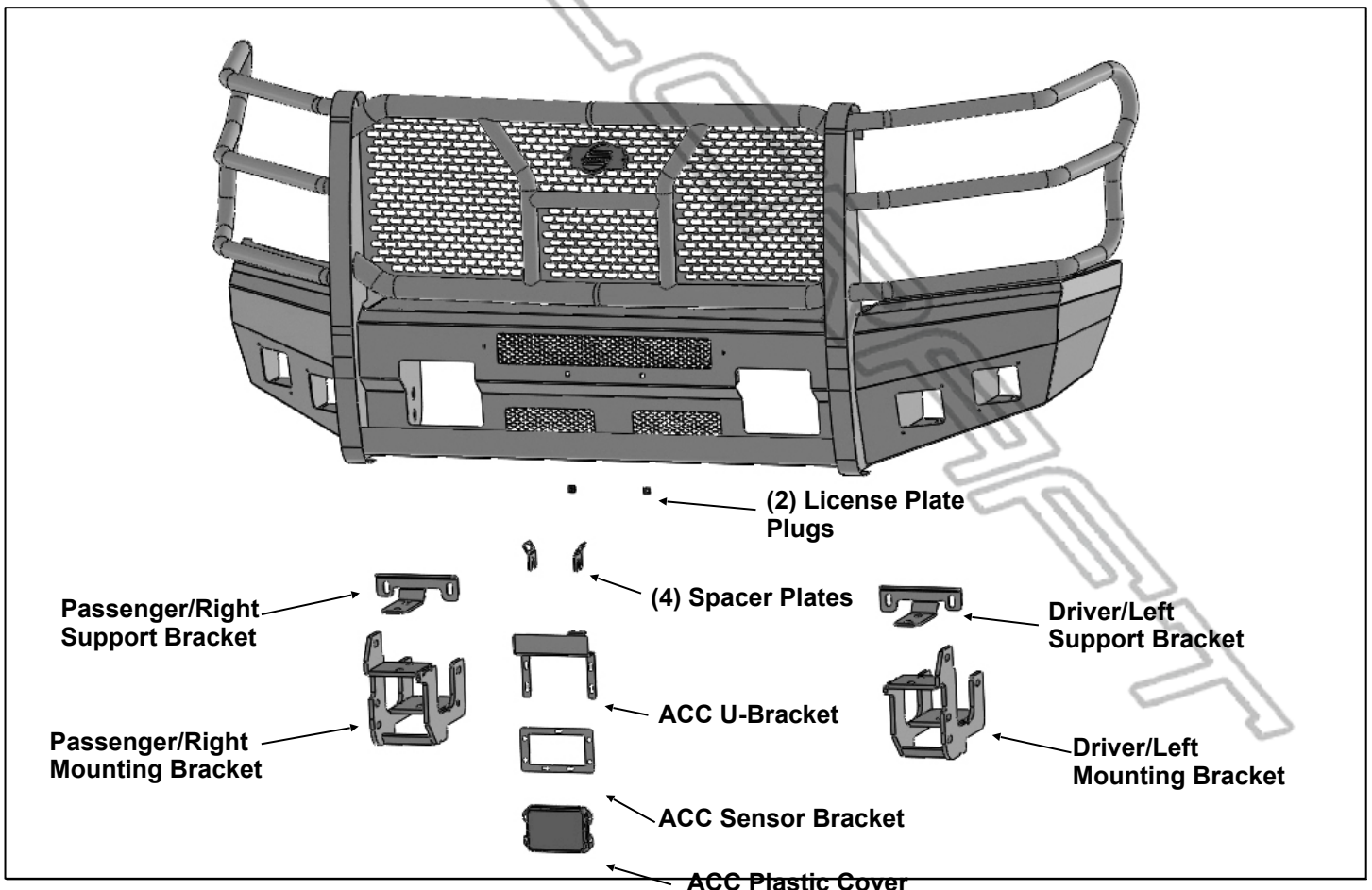

PROCEDURE:

REMOVE CONTENTS FROM BOX. VERIFY ALL PARTS ARE PRESENT. READ INSTRUCTIONS CAREFULLY BEFORE STARTING INSTALLATION. BUMPER IS HEAVY, ASSISTANCE IS HIGHLY RECOMMENDED TO AVOID POSSIBLE INJURY OR DAMAGE TO THE VEHICLE. BUMPER

1. Remove the license plate and bracket. Release the wiring harness from the clips attached to the back of the bumper. Move all wiring harnesses away from bumper.
2. Next, remove the plastic bumper pads, **(Figure 1)**. **NOTE:** Release metal clips from back of bumper to remove bumper pad assembly. It may be easier to access bumper hardware with plastic air dam removed from bottom of bumper.
3. Place blocks or jack stands under the front bumper to support it during mounting bolt removal. Once the bumper has been safely supported, remove the large hex nut from the back of each bumper bracket, **(Figure 2)**. Next, from the front of the bumper, remove the (2) factory hex nuts attaching the bumper to each bumper bracket, **(Figure 3)**. **WARNING!** Assistance is required to hold the bumper in place during bolt removal to prevent the bumper from falling. Carefully slide the bumper off over the tow hooks.
4. Remove the tow hooks and plastic covers, (if equipped), from the bottom of the frame, **(Figure 4)**.
5. Next, select the Passenger/Right Mounting Bracket, **(Figure 5)**. Slide the Bracket over the end of the frame. Insert (1) 12mm Double Nut Plate into the open end of the frame. Attach the Mounting Bracket to the bottom of the frame and the Double Nut Plate with (2) 12mm x 45mm Hex Bolts, (2) 12mm Lock Washers and (2) 12mm Flat Washers, **(Figure 5)**. **NOTE:** On models with tow hooks, reuse the factory nut plate and hardware to attach the Mounting Bracket to the bottom of the frame. Do not tighten.
6. Insert (1) 12mm x 170mm Long Hex Bolt with (1) 12mm Flat Washer through the outside of the mounting tab on the Frame Bracket, through the frame and inside tab. Secure with (1) 12mm Flat Washer and (1) 12mm Nylon Lock Nut. Insert (1) Spacer Plate down between each mounting tab and the side of the frame, **(Figure 6)**. Do not tighten.
7. Select the Passenger/Right Support Bracket, **(Figure 7)**.
On models without tow hooks,
 - a. Reuse the factory hex nuts to attach the Support Bracket to the frame, **(Figure 7)**.
 - b. Attach the Support Bracket directly to the top of the Mounting Bracket with (2) 12mm x 45mm Hex Bolts, (4) 12mm Flat Washers and (2) 12mm Nylon Lock Nuts, **(Figure 8)**. Do not tighten.**On models with tow hooks,**
 - a. Line up the Support Bracket with the top of the Mounting Bracket.
 - b. Reuse the factory hex nuts to attach the Support Bracket to the frame, **(Figure 7)**.
 - c. Slide the tow hook into the Mounting Bracket and up to the top. Attach the tow hook to the Frame Bracket and Support Bracket with (2) 12mm x 45mm Hex Bolts, (4) 12mm Flat Washers and (2) 12mm Nylon Lock Nuts, **(Figure 8)**.
8. Repeat **Steps 5—7** to attach the Driver/Left Mounting Bracket, Support Bracket and tow hook if equipped.
9. If equipped with factory fog lights, unplug both lights and remove the complete light assemblies from back of bumper, **(Figure 9)**. Unplug and remove the adaptive cruise control, if equipped.
10. **If lights are to be installed, (Lights not included):**
 - a. Attach lights to the square holes on the side of the Bumper, **(Figure 9)**.
 - b. Follow Light manufacturer's instructions to install the lights.
11. Determine if vehicle is equipped with an adaptive cruise control, (ACC), and note the design of sensor.
NOTE: Install the ACC assembly before attaching Bumper to vehicle.

Vehicles with early style ACC with tabs on ends:

- a. Select the ACC Plastic Cover and the Relocation Bracket, **(Figure 10)**. Insert (3) 6mm Button Head Bolts through the Plastic Cover, the Relocation Bracket and out through the ACC sensor. Secure with (3) 6mm Flat Washers, (3) 6mm Lock Washers and (3) 6mm Hex Nuts.
- b. Next, attach the ACC assembly to the back of the bumper with (2) 8mm Hex Bolts, (4) 8mm Flat Washers and (2) 8mm Nylon Lock Nuts, **(Figure 13)**.

Vehicles with late style ACC with tabs on top and bottom:

- a. Select the ACC Sensor Bracket, **(Figure 11)**.
- b. Attach the ACC sensor to the back of the Bracket with the included (3) 6mm Button Head Bolts, (6) 6mm Flat Washers, (3) 6mm Lock Washers and (3) 6mm Hex Nuts,
- c. Attach the ACC and Sensor Bracket to the back of the Relocation Bracket. Line up the plastic cover with the front of the Relocation Bracket. Insert (4) 6mm x 25mm Button Head Bolts through the ACC Plastic Cover, the Relocation Bracket, the Sensor Bracket, **(Figure 12)**. Secure with (4) 6mm Flat Washers, (4) 6mm Lock Washers and (4) 6mm Hex Nuts.

**ELEVATION FRONT BUMPER
2017-20 FORD RAPTOR**

- d. Next, attach the ACC assembly to the back of the bumper with (2) 8mm Hex Bolts, (4) 8mm Flat Washers and (2) 8mm Nylon Lock Nuts, **(Figure 13)**.
12. On models with grille mounted factory camera, remove the center screen.
13. With assistance, position the Bumper Assembly onto the outside of the Mounting Brackets. Temporarily support the weight of the Bumper. **WARNING:** To avoid possible injury or damage to the vehicle, do not proceed until the bumper is fully and safely supported.
14. Attach the Bumper to the Brackets with (6) 12mm x 45mm Hex Bolts, (12) 12mm Flat Washers and (6) 12mm Nylon Lock Nuts, **(Figure 14)**. Do not tighten.
15. Level and adjust the bumper and fully tighten all 12mm hardware to 65-70ft-lbs. **NOTE:** If additional in-out adjustment is required, loosen Frame Bracket Hardware, slide the Bracket in or out as necessary and fully tighten all hardware.
16. Reattach the wiring harness. Adjust lights as necessary and tighten all fog light bracket hardware.
17. Use the included (2) push-in plastic nuts to attach the front license plate, (if required), to the (2) holes in the front bumper, **(Figure 15)**.
18. Do periodic inspections to the installation to make sure that all hardware is secure and tight.

To protect your investment, Do not use any type of polish or wax that may contain abrasives that could damage the finish. Mild soap may be used to clean the Full Replacement Front Bumper assembly.

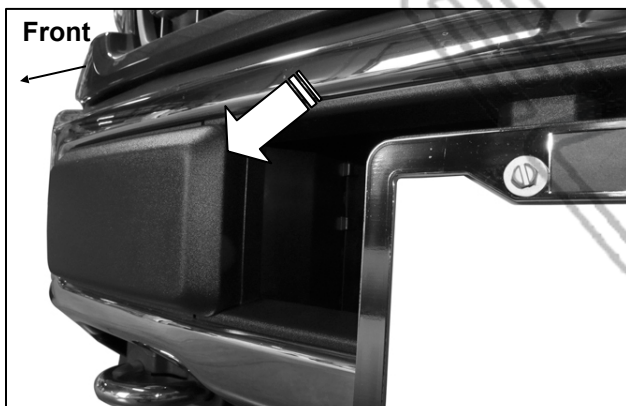

(Fig 1) From behind bumper, release metal clips attaching plastic bumper pad to the bumper

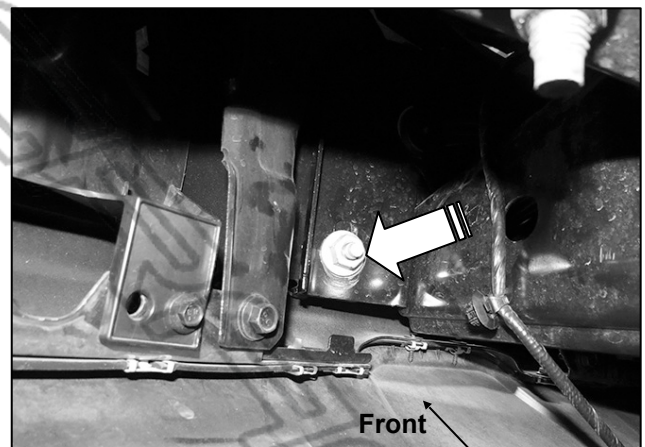

(Fig 2) Remove factory hex nut (arrow) from back of bumper bracket (Driver side pictured)

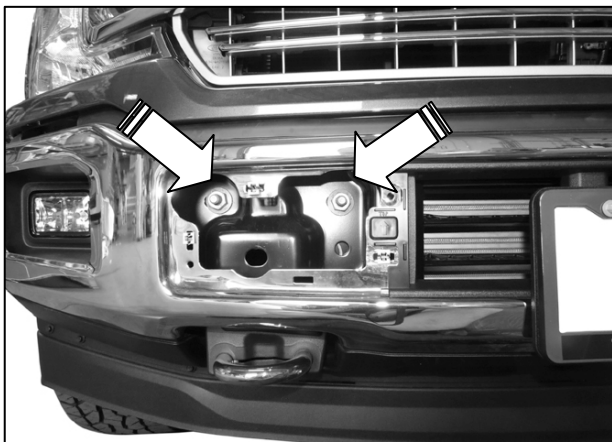

(Fig 3) Remove (2) factory hex nuts from each side

WARNING! Do not remove bumper bolts unless the bumper is properly supported on blocks or stands or the bumper may fall.

Passenger/right Side Installation Pictured

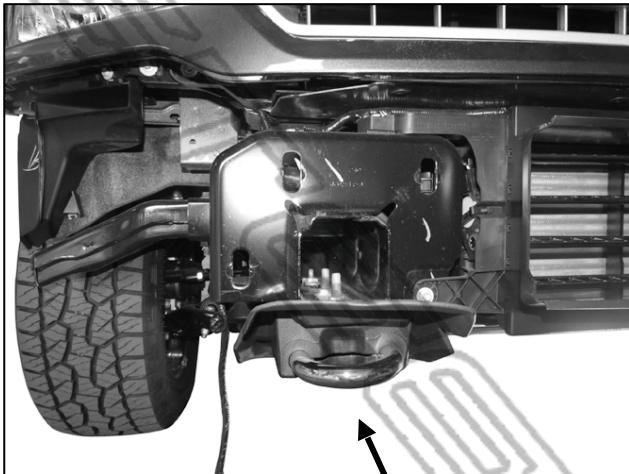

(Fig 4) Remove the tow hooks and plastic covers, if equipped

Double Nut Plate

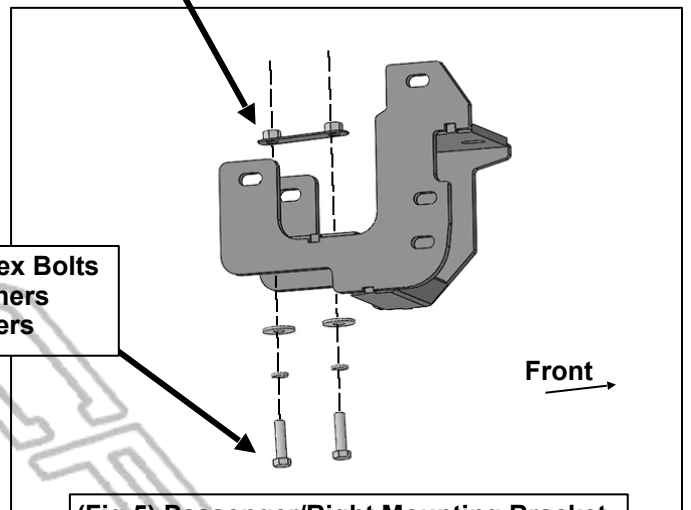

(Fig 5) Passenger/Right Mounting Bracket

- (2) 12mm x 45mm Hex Bolts
- (2) 12mm Lock Washers
- (2) 12mm Flat Washers

(2) Spacer Plates

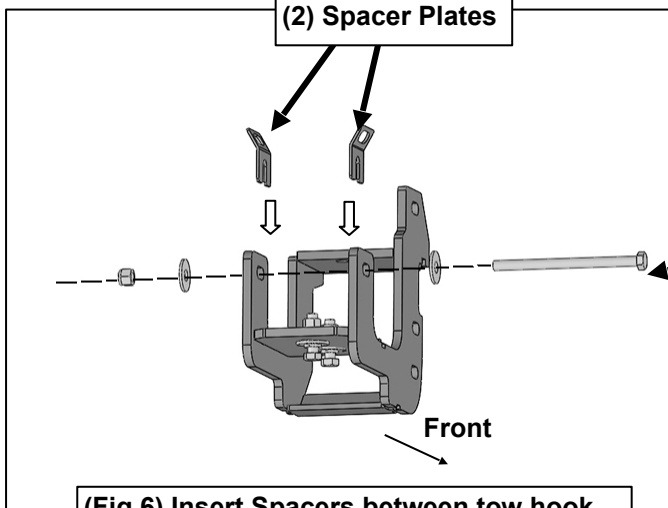

(Fig 6) Insert Spacers between tow hook and Mounting Bracket for more secure fit

- 12mm x 170mm Hex Bolt
- (2) 12mm Flat Washers
- 12mm Nylon Lock Nut

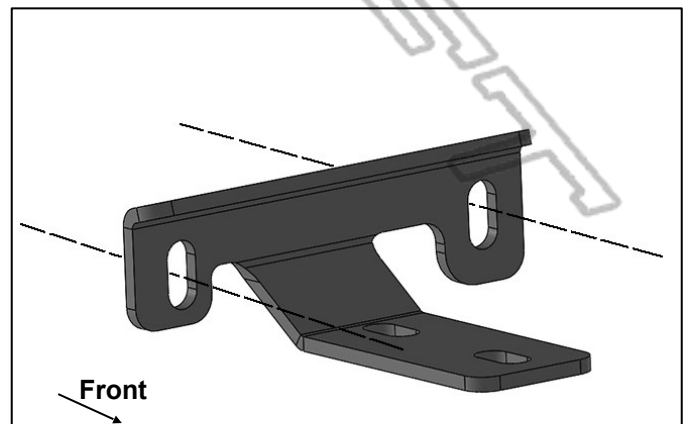

(Fig 7) Reuse the factory hardware to attach the Passenger/Right Support Bracket to the frame

Passenger/right Side Installation Pictured

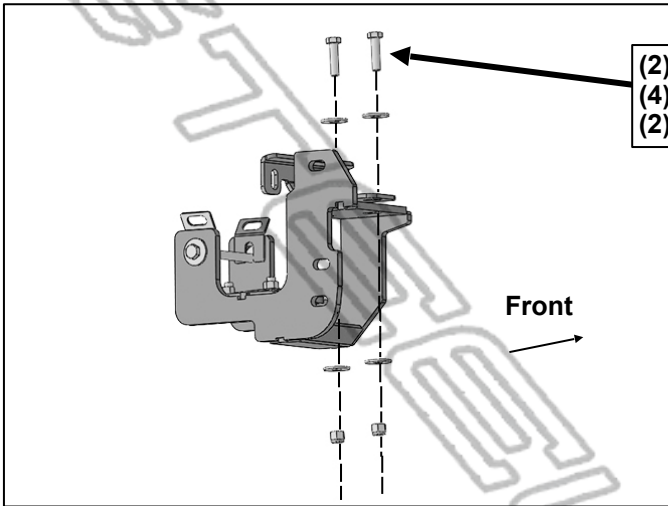

- (2) 12mm x 45mm Hex Bolts
- (4) 12mm Flat Washers
- (2) 12mm Nylon Lock Nuts

(Fig 8) Models without tow hooks, attach Passenger/Right Support Bracket to the top of the Frame Bracket. Models with tow hooks, attach tow hook to inside top of Mounting Bracket

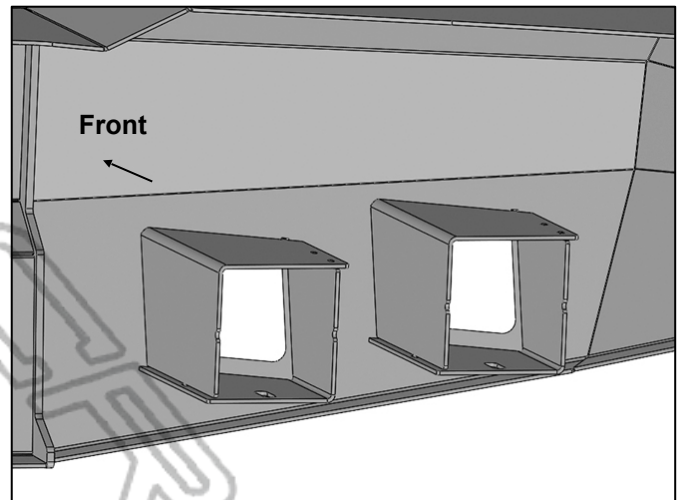

(Fig 9) Optional Attach lights to the sides of the Bumper, (Lights not included)

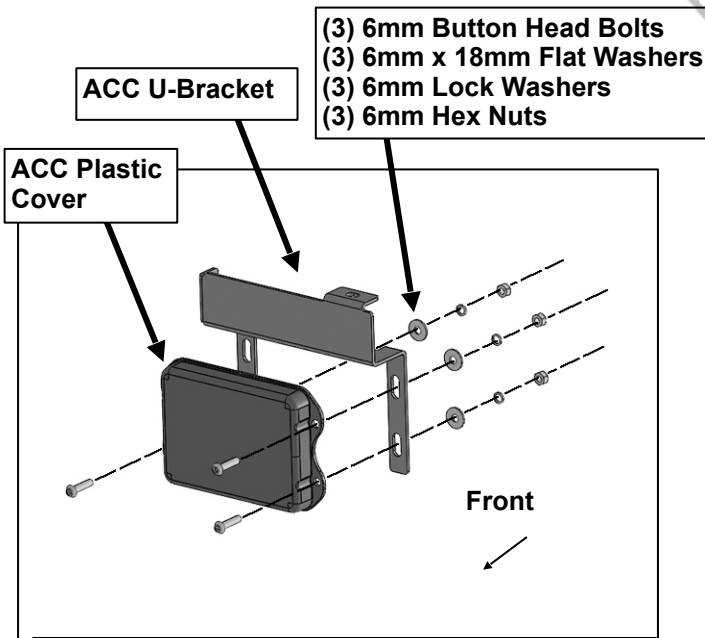

(Fig 10) Attach Plastic Cover and "early style" Adaptive Cruise Control sensor to U-Bracket

- (3) 6mm Button Head Bolts
- (3) 6mm x 18mm Flat Washers
- (3) 6mm Lock Washers
- (3) 6mm Hex Nuts

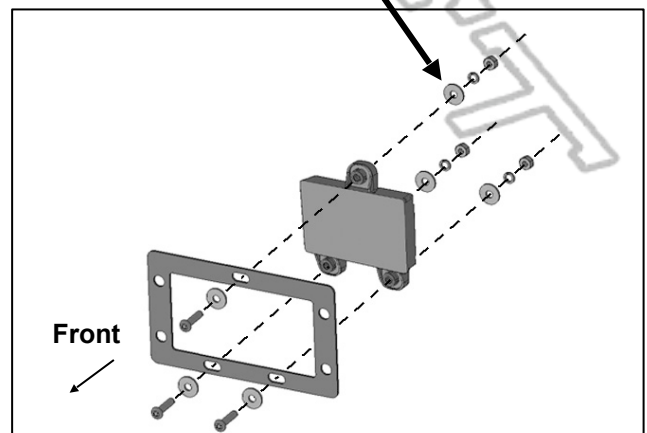

(Fig 11) Attach the "late style" ACC sensor to back of Adapter Plate

Passenger/right Side Installation Pictured

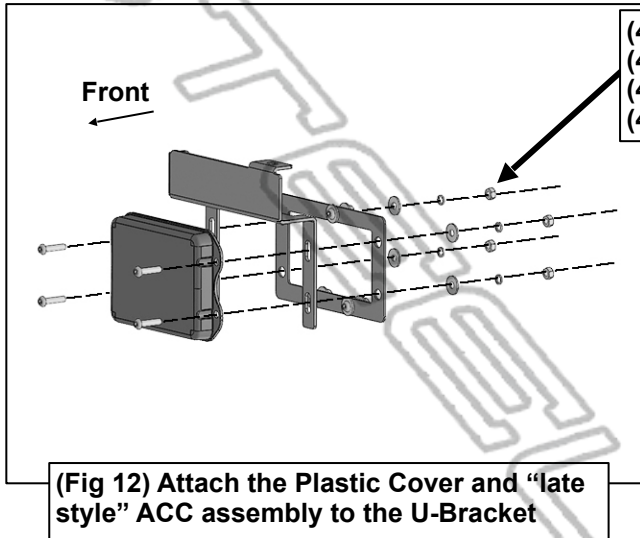

- (4) 6mm Button Head Bolts
- (4) 6mm x 18mm Flat Washers
- (4) 6mm Lock Washers
- (4) 6mm Hex Nuts

- (2) 8mm Hex Head Bolts
- (4) 8mm Flat Washers
- (2) 8mm Nylon Lock Nuts

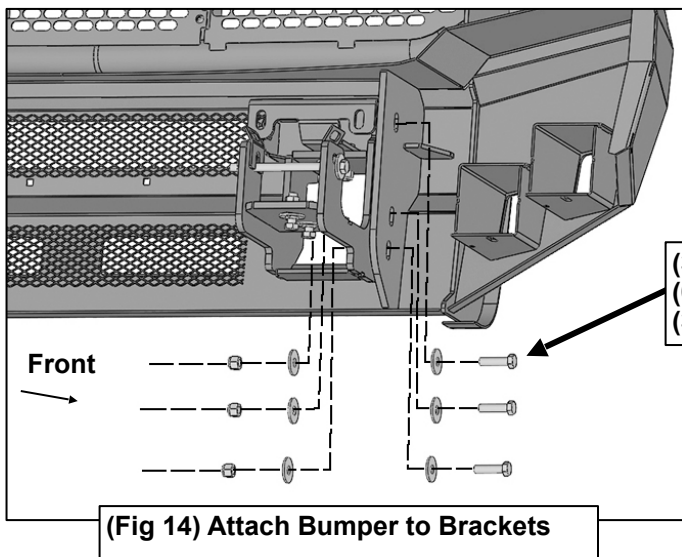
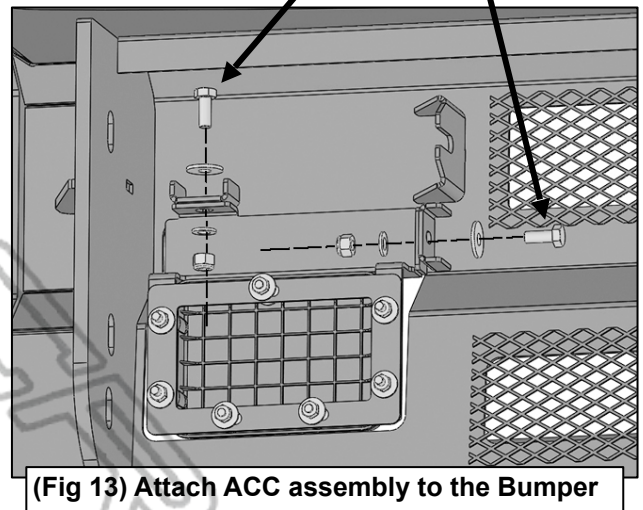

- (3) 12mm x 45mm Hex Bolts
- (6) 12mm Flat Washers
- (3) 12mm Nylon Lock Nuts

**ELEVATION FRONT BUMPER
2017-20 FORD RAPTOR**

WARNING! Do not crawl under bumper unless the bumper is properly supported on blocks or stands or the bumper may fall.

