

WINCH FAIRLEAD LICENSE PLATE BRACKET

PARTS LIST:

1	License Plate Bracket	2	10mm Hex Nuts
1	Mounting Bracket	2	8-1.25mm x 30mm Button Head Bolts
2	License Plate Plugs	1	8-1.25mm x 30mm Wing Bolt
2	Nylon Spacer Washers	3	8mm Lock Washers
2	10-1.5mm x 35mm Button Head Bolts	3	8mm x 16mm OD x 1.6mm Flat Washers
2	10mm x 30mm OD x 2.5mm Large Flat Washers	1	6mm Hex Wrench
2	10mm x 20mm OD x 2mm Small Flat Washers	1	5mm Hex Wrench
2	10mm Lock Washers		

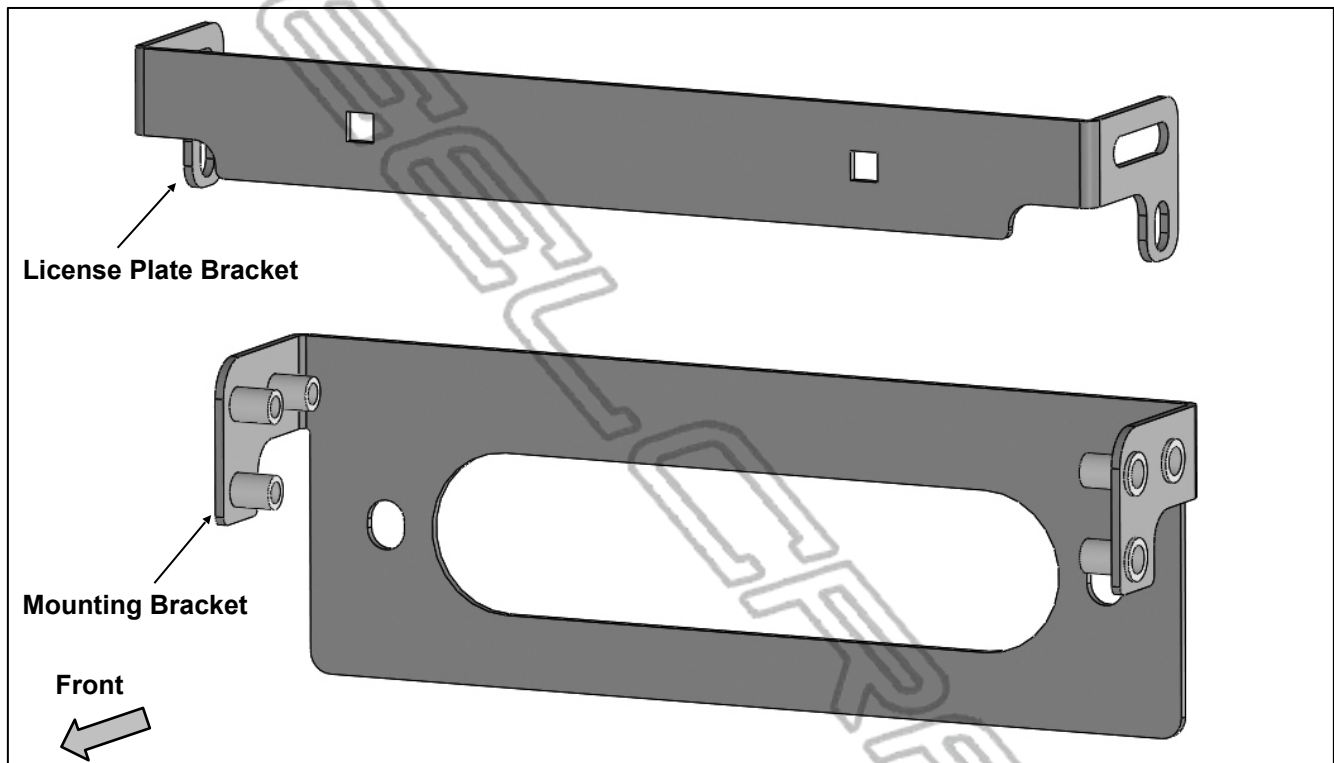

PROCEDURE: REMOVE CONTENTS FROM BOX. VERIFY ALL PARTS ARE PRESENT. READ INSTRUCTIONS CAREFULLY BEFORE STARTING INSTALLATION.

1. Start the installation on the front side of the vehicle. Locate the winch lead mounting location. Temporarily remove the winch lead, if previously installed. Select the Mounting Bracket. Attach the Bracket to the winch lead mounting location with (2) 10mm Button Head Bolts, (2) 10mm x 20mm Small Flat Washers, (2) 10mm x 30mm Large Flat Washers, (2) 10mm Lock Washers and (2) 10mm Hex Nuts, **(Figure 1)**. Do not tighten hardware.
2. Select the License Plate Bracket. Attach the Bracket to the Mounting Bracket with (2) 8mm Button Head Bolts, (2) 8mm Lock Washers, (2) 8mm Flat Washers and (2) Nylon Spacer Washers, **(Figure 2)**. **NOTE:** Depending on the type of winch lead equipped, determine if the License Plate Bracket will attach to the inner or outer threaded holes in the Mounting Bracket. Do not tighten hardware.
3. Attach the Passenger/Right Front Support Bracket to the Mounting Bracket with (1) 10mm x 30mm Hex Bolt, (2) 10mm x 20mm Flat Washers, (1) 10mm Lock Washer and (1) 10mm Hex Nut, **(Figures 6 & 7)**. Do not tighten hardware.
4. Select the (2) License Plate Plugs and insert them into the License Plate Bracket, **(Figure 3)**.
5. Level and adjust the Fairfield Pivoting License Plate Bracket and fully tighten all hardware.
6. Do periodic inspections to the installation to make sure that all hardware is secure and tight.

WINCH FAIRLEAD LICENSE PLATE BRACKET

To protect your investment, Do not use any type of polish or wax that may contain abrasives that could damage the finish. Mild soap may be used also to clean the License Plate Brackets.

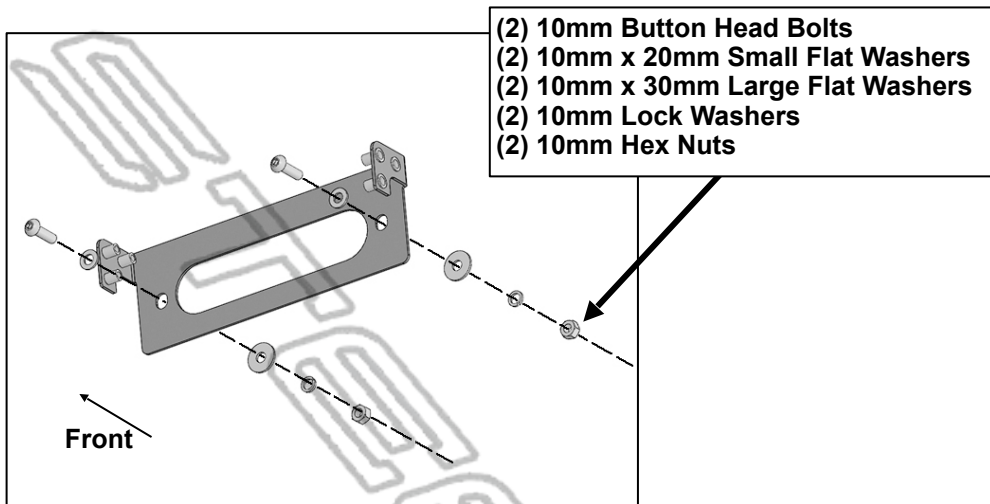

(Fig 1) Attach the Mounting Bracket to the winch opening on the front of the bumper

8mm Button Head Bolt
8mm Lock Washer
8mm Flat Washer
Nylon Spacer

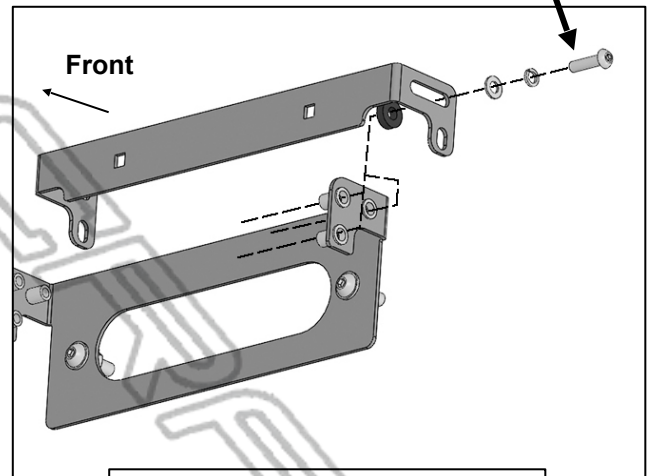

(Fig 2) Attach the License Plate Bracket to the Mounting Bracket

NOTE: For roller winch leads, attach the License Plate Bracket to the outer threaded holes. For non-rolling winch leads, attach the License Plate Bracket to the inner threaded holes

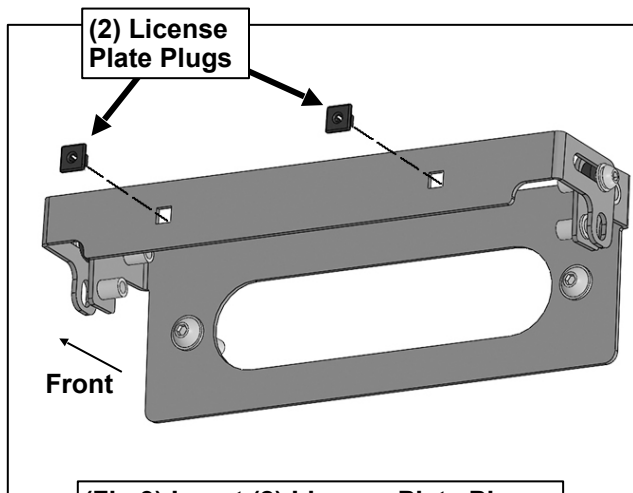

(Fig 3) Insert (2) License Plate Plugs into the License Plate Bracket