

PARTS LIST:

1	3in Bull Bar	4	10mm x 35mm Double Bolt Plates
1	Driver/left Frame Bracket	8	10-1.5mm x 30mm Hex Bolts
1	Passenger/Right Frame Bracket	24	10mm x 27mm OD x 3mm Flat Washers
1	Driver/left Bull Bar Mounting Bracket	16	10-1.5mm Nylon Locknuts
1	Passenger/right Bull Bar Mounting Bracket		

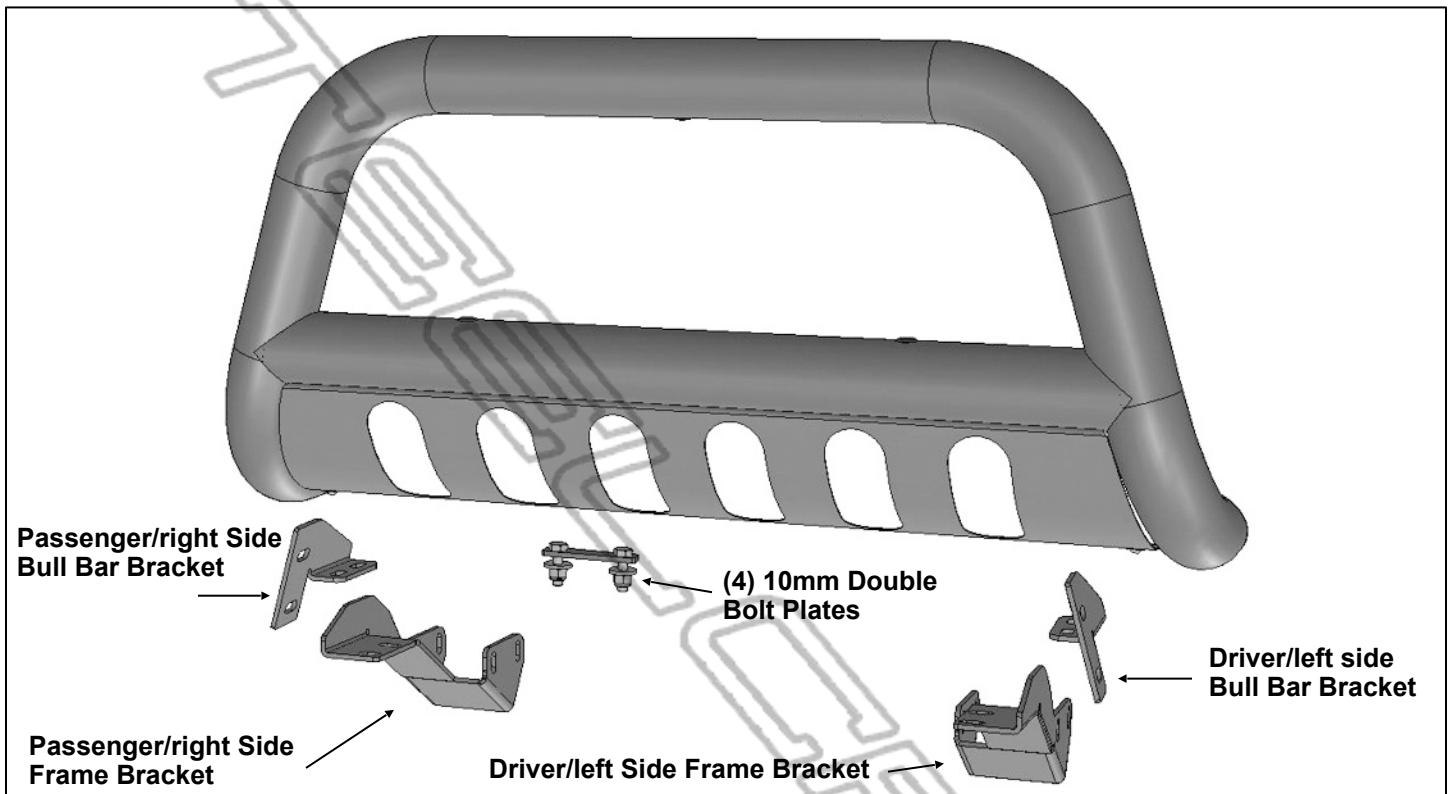

PROCEDURE:

REMOVE CONTENTS FROM BOX. VERIFY ALL PARTS ARE PRESENT. READ INSTRUCTIONS CAREFULLY BEFORE STARTING INSTALLATION. CUTTING MAY BE REQUIRED. INSTALLATION MAY INTERFERE WITH BUMPER MOUNTED PARKING SENSORS. ASSISTANCE IS RECOMMENDED. NOTE: It may be necessary to remove/relocate front license plate and license plate bracket. It is not required, but strongly recommended. If local/state law requires a front license plate, license plate relocation kit is available.

- Starting at the driver side, remove the factory tow hook if equipped, **(Figure 1)**. **NOTE:** The factory tow hooks cannot be reinstalled. **IMPORTANT:** On some model years, with and without tow hooks, the pocket in the plastic bumper may need to be trimmed or completely cut out, **(Figure 4)**. Use a sharp knife or hacksaw blade and carefully cut out the pocket to clear the Bull Bar Brackets. Only cut enough to clear the Brackets.
- Select the driver/left Frame Bracket, **(Figure 2)**. Carefully slide the Bracket through the tow hook opening and over the end of the frame. Insert (1) 10mm Double Bolt Plate up and into the end of the frame channel and out through the holes in the for the tow hook and the Bracket, **(Figures 2—4)**. Secure the Bracket to the Double Bolt Plate with (2) 10mm Flat Washers and (2) 10mm Nylon Lock Nuts. Leave hardware loose. Repeat this Step to install a second Double Bolt Plate in the other side of the frame.
- Next, select the driver/left Bull Bar Mounting Bracket, **(Figure 5)**. Attach the Bull Bar Bracket to the top of the Frame Bracket with the included (2) 10mm x 30mm Hex Bolts, (4) 10mm Flat Washers and (2) 10mm Nylon Lock Nuts, **(Figure 6)**. Leave hardware loose at this time.

4. Repeat **Steps 1—3** to install the passenger/right Frame and Bull Bar Bracket.
5. With assistance, position the Bull Bar assembly up to the inside of the Mounting Brackets. Attach the Bull Bar to the Brackets with the included (4) 10mm x 30mm Hex Bolts, (8) 10mm Flat Washers and (4) 10mm Nylon Lock Nuts, (**Figures 7 & 8**). Do not fully tighten hardware at this time.
6. Level and adjust the Bull Bar and fully tighten all hardware.
7. Do periodic inspections to the installation to make sure that all hardware is secure and tight.

To protect your investment, wax this product after installing. Regular waxing is recommended to add a protective layer over the finish. Do not use any type of polish or wax that may contain abrasives that could damage the finish.

For stainless steel: Aluminum polish may be used to polish small scratches and scuffs on the finish. Mild soap may be used also to clean the Bull Bar.

For gloss black finishes: Mild soap may be used to clean the Bull Bar.

Driver/left Side Installation Pictured

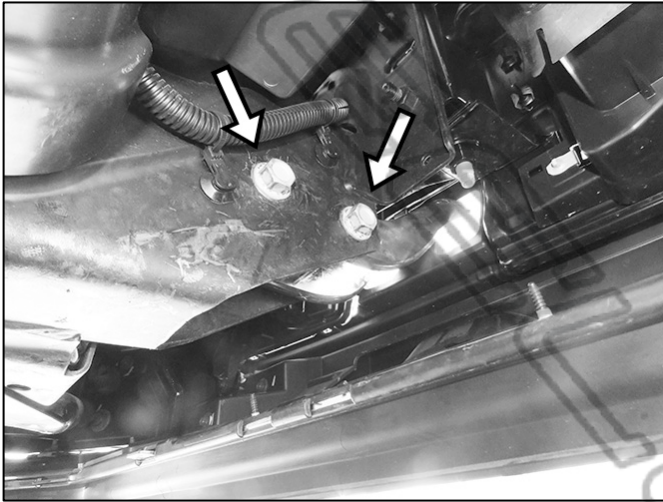

(Fig 1) Remove the tow hook and hardware, (arrows). Driver/left tow hook pictured from below bumper

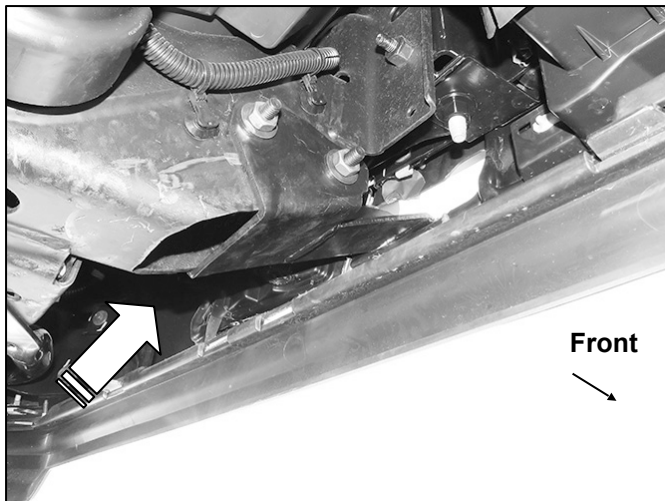

(Fig 3) Driver/left side Frame Bracket installed

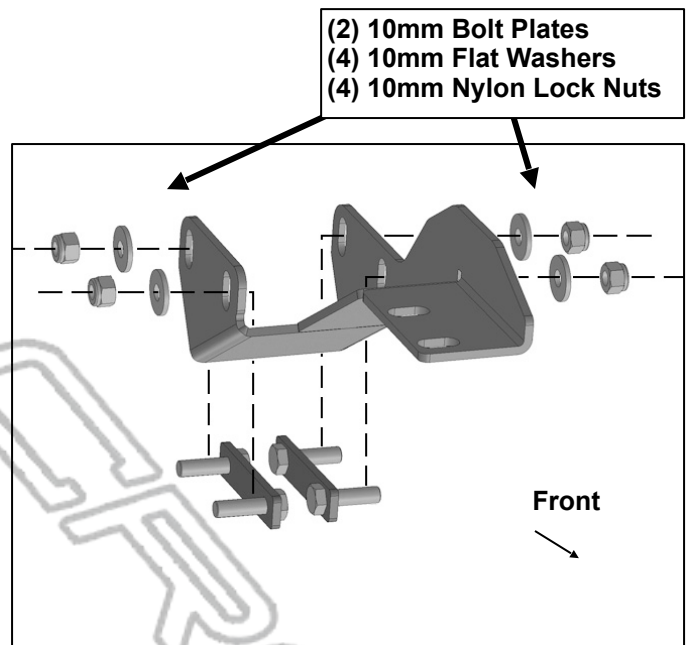

(Fig 2) Insert (2) 10mm Double Bolt Plates up into the open end of driver/left side frame channel and out through the Frame Bracket, (also see Fig 3)

Driver/left Side Installation Pictured

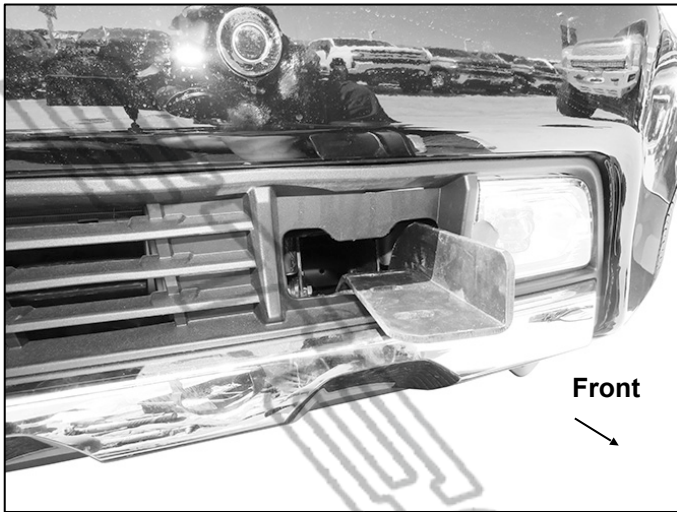

(Fig 4) Trim plastic opening if necessary

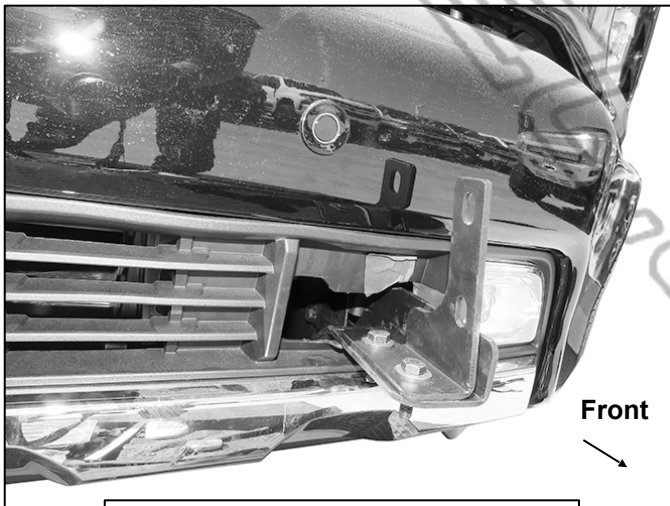

(Fig 6) Driver/left Brackets installed



(Fig 8) Bull Bar installed

- (2) 10mm x 30mm Hex Bolts
- (4) 10mm Flat Washers
- (2) 10mm Nylon Lock Nuts

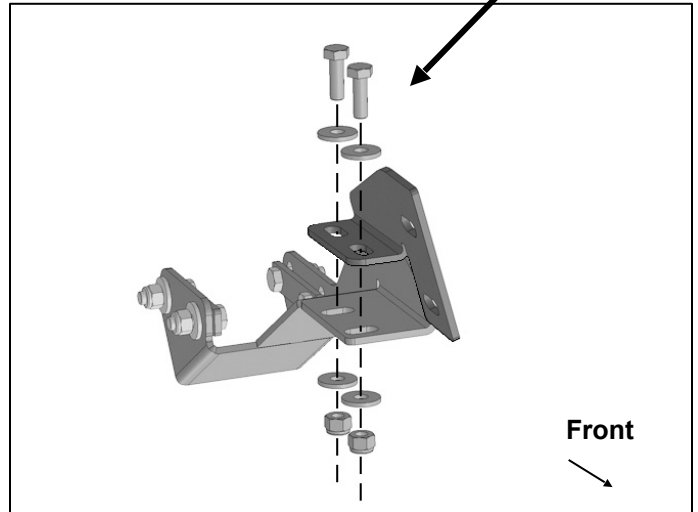

(Fig 5) Attach driver/left Bull Bracket to top of Frame Bracket

- (2) 10mm x 30mm Hex Bolts
- (4) 10mm Flat Washers
- (2) 10mm Nylon Lock Nuts

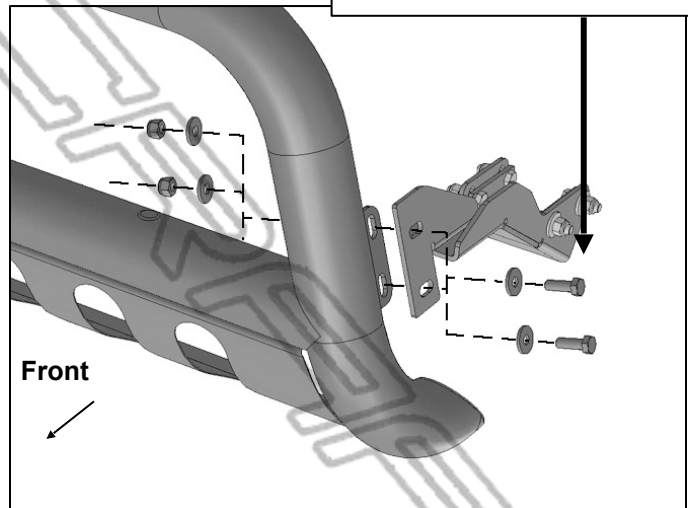

(Fig 7) Attach Bull Bar to inside of Mounting Brackets

