

**FORTIS FRONT WINCH BUMPER
2023-24 FORD SUPER DUTY**

PARTS LIST:

1	Front Bumper	20	12mm x 50mm Hex Bolts
1	Winch Tray	48	12mm x 32mm x 3mm Flat Washers
1	Driver/left Mounting Bracket	28	12mm Hex Nuts
1	Passenger/right Mounting Bracket	28	12mm Lock Washers
1	Driver/left LED L-bracket	8	12mm Bolt Plates
1	Passenger/right LED L-bracket	4	8mm Hex Nuts
1	Adaptive Cruise Control (ACC) Plastic Cover	6	8mm Lock Washers
1	ACC Sensor Relocation Bracket	4	8mm x 25mm Hex Bolts
1	ACC Cover Bracket	2	8mm x 16mm Hex Bolts
1	Adhesive Backed Foam Pad	10	8mm x 24mm OD x 2mm Flat Washers
2	Parking Sensor Wire Extenders	7	6mm Lock Washers
1	Sensor Cover Kit	7	6mm Hex Nuts
4	Plastic Sensor Hole Plugs	3	6mm x 25mm Hex Bolts
4	Sensor Retaining Caps	4	6mm x 20mm Button Head Bolts
4	25mm x 15mm Foam Washer Sensor Seals	10	6mm x 18mm x 1.6mm Flat Washers
4	20mm x 10mm Foam Sensor Spacers	1	4mm Allen Wrench
8	4mm Self-tapping Screws	2	License Plate Plugs

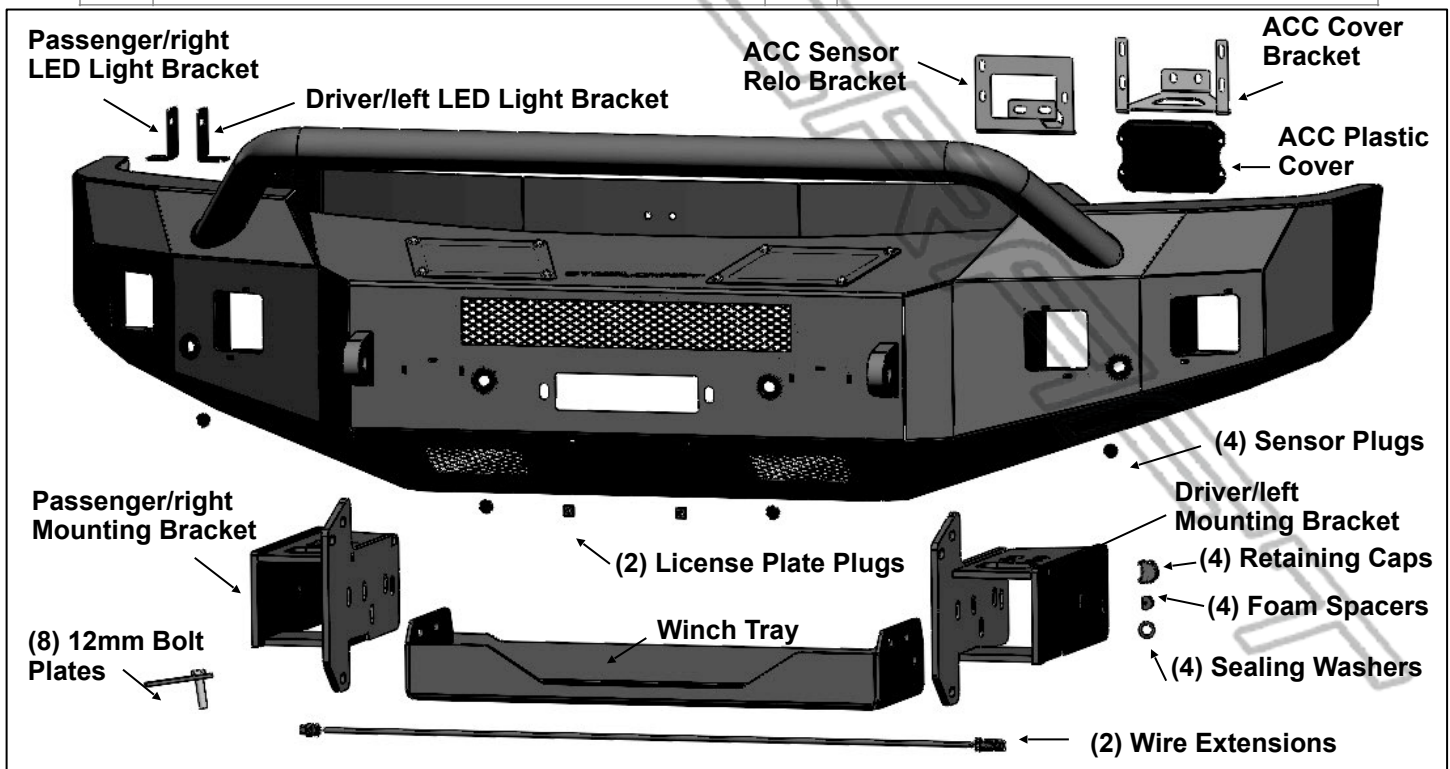

PROCEDURE:

**FORTIS FRONT WINCH BUMPER
2023-24 FORD SUPER DUTY**

SOME PARTS ARE SMALL AND WILL BE HIDDEN IN WRAPPINGS. REMOVE CONTENTS FROM PACKAGING. VERIFY ALL PARTS ARE PRESENT. READ INSTRUCTIONS CAREFULLY BEFORE STARTING INSTALLATION. BUMPER IS HEAVY, ASSISTANCE IS HIGHLY RECOMMENDED TO AVOID POSSIBLE INJURY OR DAMAGE TO THE VEHICLE.

1. Remove the license plate. Unplug all wiring harnesses connecting bumper to vehicle (**Figure 1**).
2. Remove the bumper supports attaching the outer ends of the bumper to the outside of the frame, (**Figure 2**). Remove the plastic covers from the tow hooks to uncover the bumper bolts, (**Figure 3**).
3. Place blocks or jack stands under the front bumper to support it during mounting bolt removal. Once the bumper has been safely supported, remove the (8) factory bumper bolts, (**Figure 4**).
WARNING! Assistance is required to hold the bumper in place during bolt removal to prevent the bumper from falling. Carefully slide the bumper off over the tow hooks. There will be 2 plastic pins that attach the bumper to the grille that need to be pried off (**Figure 5**).
4. Remove the driver/left side tow hook from the end of the frame, (**Figure 6**). Next, remove the (4) factory hex nuts, lower frame extension and double bolt plates from the end of the frame, (**Figure 6**). Repeat this Step to remove the passenger/right side tow hook and lower frame extension. Note: tow hooks will not be re-installed.
5. Next, select the Driver/left Mounting Bracket. Slide the Bracket over the end of the frame. Line up the slots in the side of the Bracket with the holes in the sides of the frame. Select (4) 12mm Bolt Plates. Insert the Bolt Plates into the open end of the frame and out through each side of the Bracket. Attach the Bracket to the Bolt Plates with (4) 12mm Flat Washers, (4) 12mm Lock Washers and (4) 12mm Hex Nuts, (**Figure 7**). Leave loose at this time.
6. Attach the top of the Bracket to the top of the frame at the original tow hook location with the included (4) 12mm x 50mm Hex Bolts, (8) 12mm Flat Washers, (4) 12mm Lock Washers and (4) 12mm Hex Nuts, (**Figure 8**). Do not fully tighten hardware yet.
7. Repeat **Steps 5 & 6** for Passenger/right side Bracket installation.
8. Next, select the Winch Tray Assembly, (**Figure 9**). Slide the Winch Tray between the two Brackets. Attach the Winch Tray to the Brackets with (6) 12mm x 50mm Hex Bolts, (12) 12mm Flat Washers, (6) 12mm Lock Washers and (6) 12mm Hex Nuts, (**Figure 9**). Leave hardware loose.
9. If installing winch, attach winch to Winch Tray at this time. Winch must be installed before Bumper is placed in position against Brackets. Also attach winch cable guide, (not included), to Bumper. Follow manufacturer's instructions to properly wire the winch to the electrical system.
10. **Optional Center 20-inch LED light bar (sold separately) - side mount installation:**
 - a. Select the L/R "L" Brackets. **NOTE:** "L" Brackets are offset for universal fitment for most side mount LED bar style lights. Attach the LED light assembly to the "L" Brackets with the included (2) 8mm x 16mm Hex Bolts, (2) 8mm Lock Washers and (2) 8mm Flat Washers, (**Figure 10**). Do not fully tighten hardware at this time. **NOTE:** Some hardware provided with the light can be used. "L" Brackets may require modification for hardware larger than 8mm or use brackets supplied with light if possible.
 - b. Attach the light and brackets to the top of the (2) tabs on the back of the Bumper with the included 8mm x 25mm Hex Bolts, (4) 8mm Flat Washers, (2) 8mm Lock Washers and (2) 8mm Hex Nuts, (**Figure 10**). Adjust light position and tighten hardware.
 - c. Follow light manufacturer's instructions to wire the light to the vehicle's electrical system once Bumper has been fully installed. Note: installation of a light bar can affect airflow to the coolers.
11. Determine if the vehicle is equipped with adaptive cruise control, (ACC)
Vehicles without ACC, skip to Step 12.
Vehicles equipped with ACC sensor:
 - a. Remove the 3 nuts securing the ACC sensor to the front of the OE bumper. (**Figure 11**). Unplug the wiring harness and remove the sensor and bracket from the bumper by pulling straight-out.
 - b. Select the provided ACC Sensor Relocation Bracket and attach the sensor with (3) 6mm x 25mm Hex Bolts, (6) 6mm Flat Washers, (3) 6mm Lock Washers and (3) 6mm Hex Nuts, (**Figure 12**). Note: Pay attention that the sensor matches the OE configuration and is straight + level. This may require fine tuning at the end of the install.
 - c. Select the Foam Pad, remove adhesive backing and attach to bottom of ACC Bracket, (**Figure 13**).
 - d. Remove the rubber plugs from the top of the new Fortis Bumper. Select the ACC Cover Bracket and place it in front of the holes, then attach the sensor Relocation assembly from the previous **step** inside the ACC Cover Bracket and through the bumper with (2) 8mm x 25mm Hex Bolts, (4) 8mm

**FORTIS FRONT WINCH BUMPER
2023-24 FORD SUPER DUTY**

Flat Washers, (2) 8mm Lock Washers and (2) 8mm Hex Nuts, (**Figure 14**). Make sure sensor is level.

- e. Select the ACC Plastic Cover. Insert (4) 6mm x 25mm Button Head Bolts through the (4) holes on the ACC Plastic Cover to each side of the ACC cover bracket. Secure with (4) 6mm Flat Washers, (4) 6mm Lock Washers and (4) 6mm Hex Nuts, (**Figure 15**). Make sure sensor is centered behind Cover.

12. Determine if truck is equipped with front parking sensors.

For vehicles not equipped with front parking sensors.

- a. Select the included (4) Plastic Parking Sensor Plugs. From the front of the bumper, push plugs into sensor sleeves, (**Figure 16**).

For vehicles equipped with front parking sensors.

- a. Remove the parking sensors and wiring from the factory bumper.
- b. Select a sensor and remove the OE silicone seal from the end of the sensor. Remove the adhesive backing from the supplied 15.5mm x 25mm x 2mm Foam Washer Sensor Seal. Slide the Foam Seal over front of sensor (**Figure 17**).
- c. Insert sensor with Seal into sensor mount on back of bumper until it clicks into place, (**Figure 18**).
- d. Select the included (1) Foam Spacer and peel off the adhesive backing. Place Foam Spacer into (1) Sensor Retainer Cap. Push Sensor Retaining Cap and Foam Spacer onto sensor mount and lock into mounting holes, (**Figure 18**).
- e. Repeat previous **Steps** to install remaining sensors.

13. **LED cube light, pedestal mount installation at ends of bumper** (sold separately).

- a. Insert light into opening and up to mounting slots.
- b. Follow light manufacturer's instructions to attach each light to the slot in the bottom of the light opening. On two light systems, attach flood light to outer slot and spot light to inner slot.
- c. Follow light manufacturer's instructions to properly wire the light to the vehicle electrical system.

14. With assistance, carefully position the Bumper Assembly up to the outside of the Mounting Brackets, (**Figure 19**). Temporarily support the weight of the Bumper. **WARNING:** To avoid possible injury or damage to the vehicle, do not proceed until the bumper is fully and safely supported. Models with LED light bar, check for winch clearance before fully installing Bumper assembly.

15. Attach the Bumper to the outside of the Mounting Brackets with the included (6) 12mm Hex Bolts, (12) 12mm Flat Washers, (6) 12mm Lock Washers and (6) 12mm Hex Nuts, (**Figure 19**).

16. Level and adjust the bumper, then fully tighten all hardware for the Winch Tray and Brackets.

17. Transfer factory bumper wiring to new Fortis bumper and connect all sensors, if equipped.

18. Insert (2) Plastic Plugs into the square holes in the front of the Bumper if front license plate is required. Reuse the factory screws to attach the license plate to the plastic plugs, (**Figure 20**).

19. Do periodic inspections to the installation to make sure that all hardware is secure and tight.

To protect your investment, Do not use any type of polish or wax that may contain abrasives that could damage the finish. Mild soap may be used to clean the Front Bumper assembly.

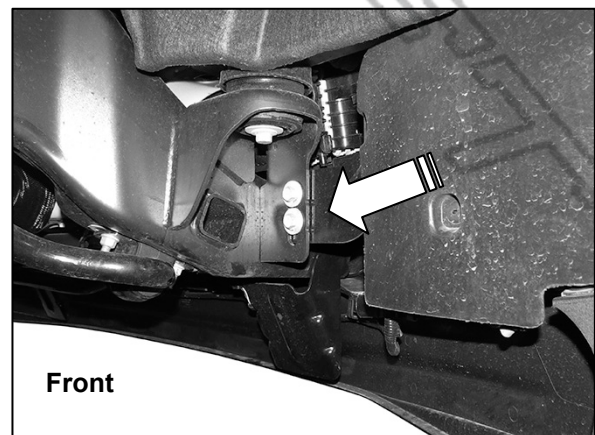
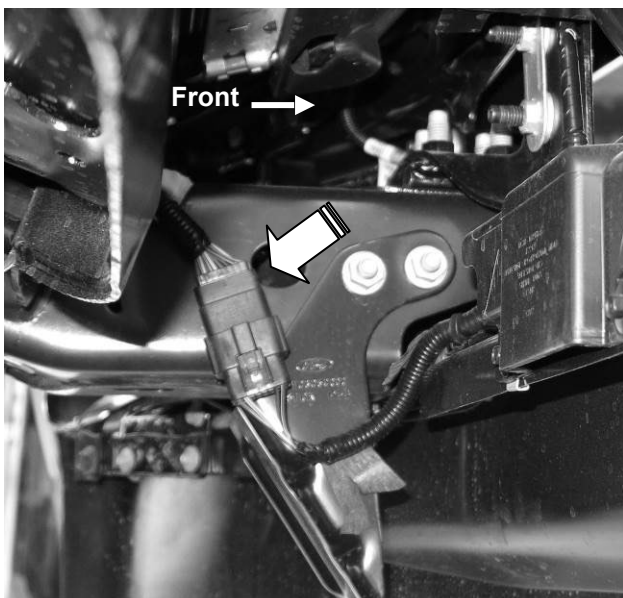

**FORTIS FRONT WINCH BUMPER
2023-24 FORD SUPER DUTY**

**(Fig 1) Unplug wire harness from
behind bumper (driver side pictured)**

**(Fig 2) Remove outer bumper support
brackets between frame and bumper (arrow)
[Passenger side shown]**

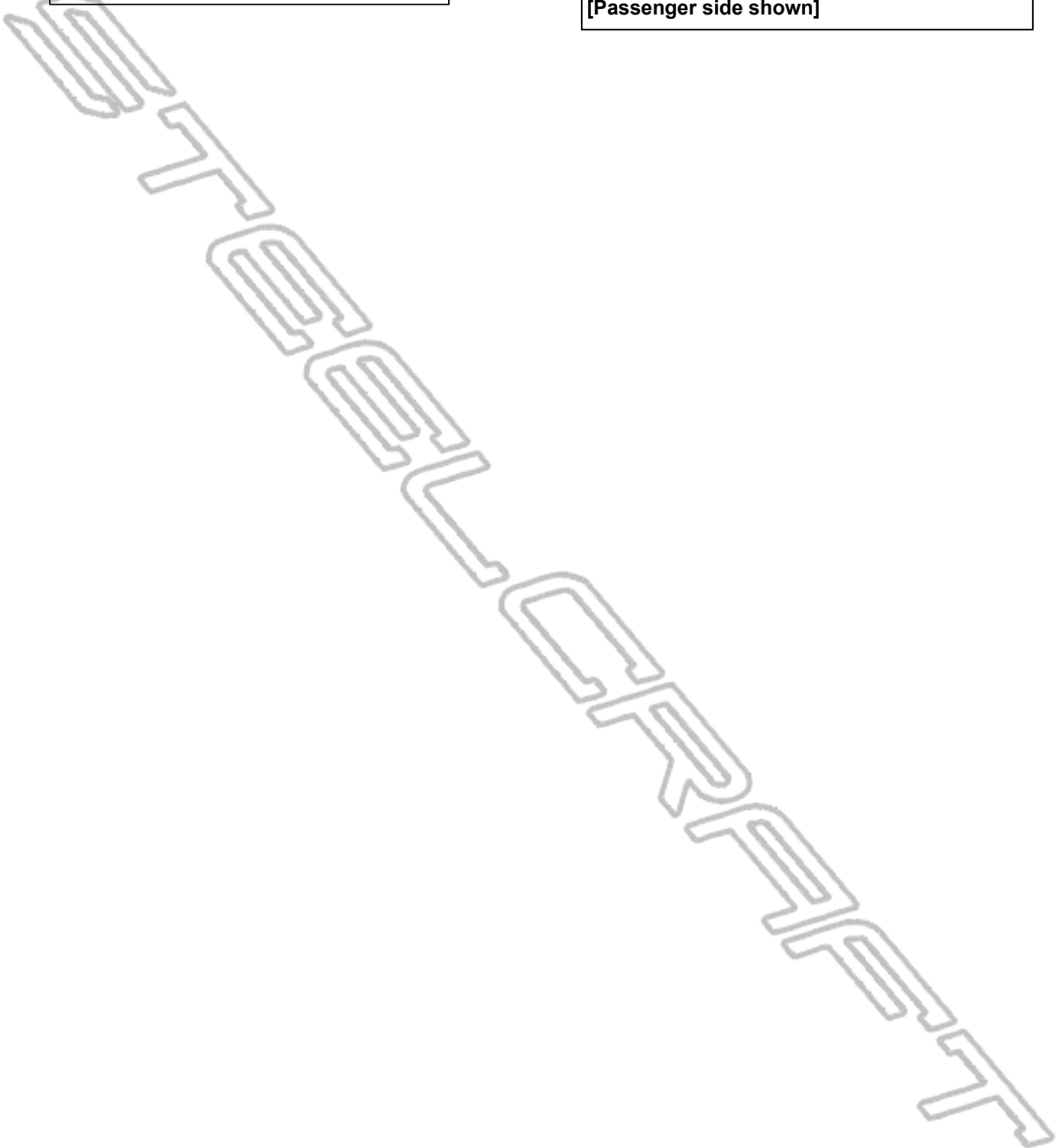

Driver/left Side Installation Pictured



(Fig 3) Remove plastic cover around tow hook

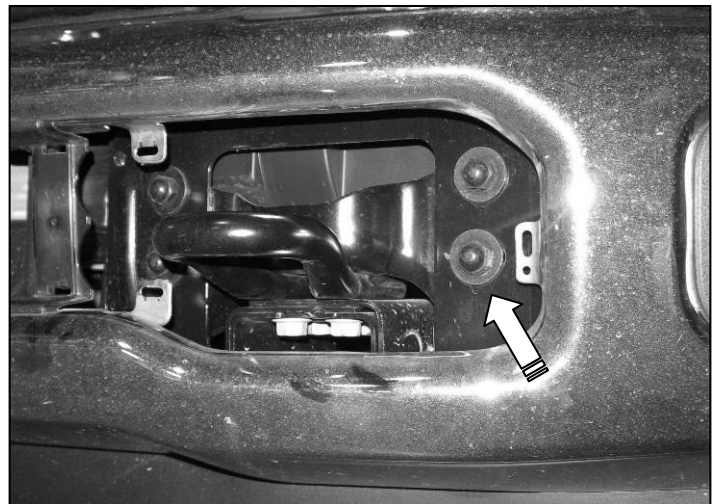

(Fig 4) Remove bumper bolts

WARNING! Do not remove bumper bolts unless the bumper is properly supported on blocks or stands or it may fall.



(Fig 5) Remove the clips attaching rubber bumper trim to grille.

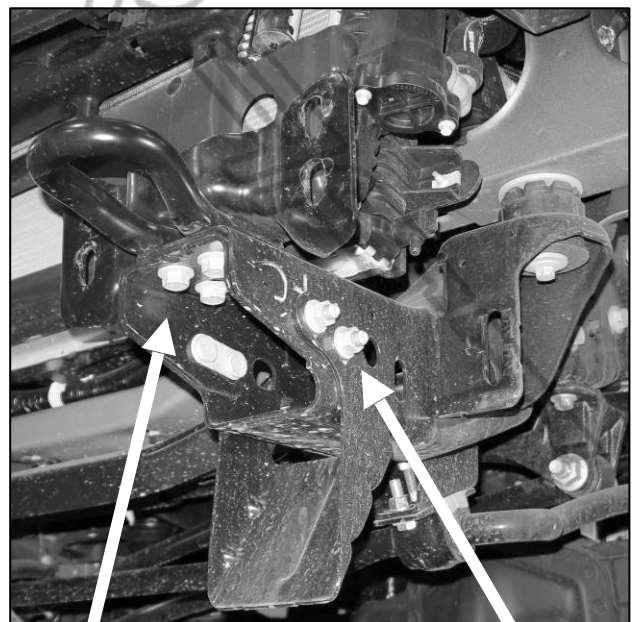

(Fig 6) Remove tow hook assembly and lower frame extension

Driver/left Side Installation Pictured

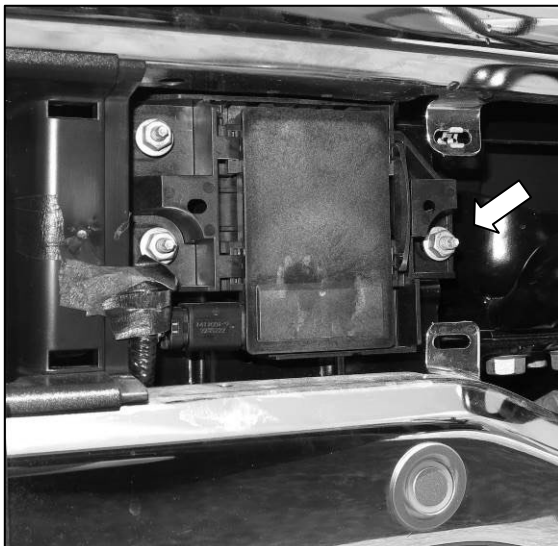
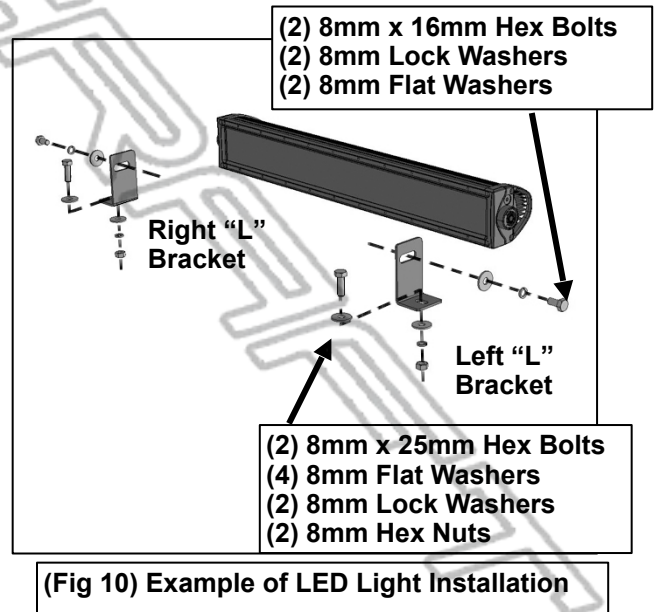
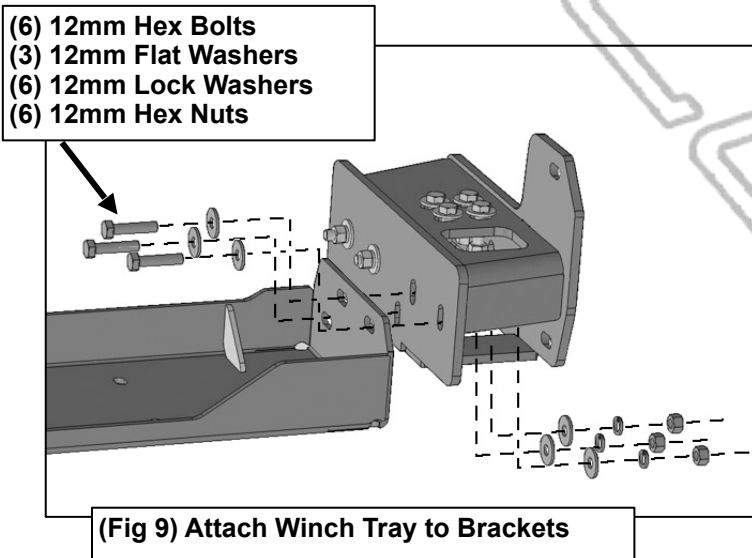
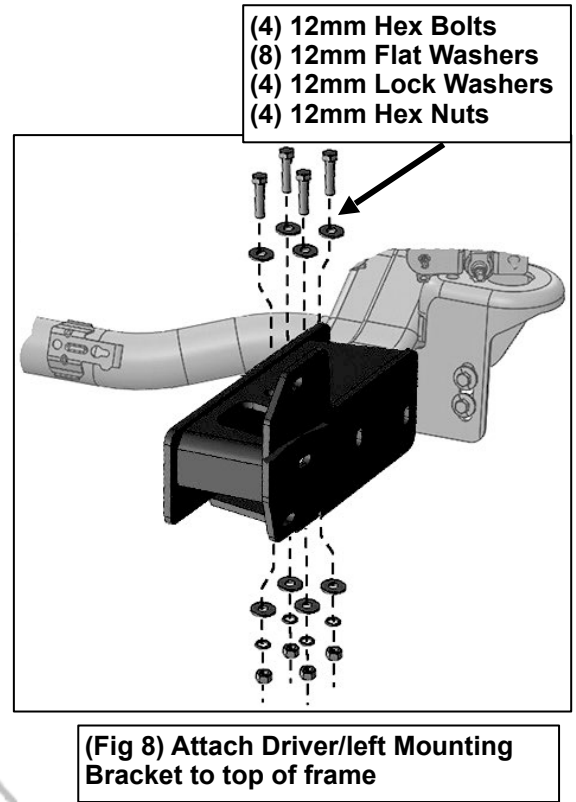
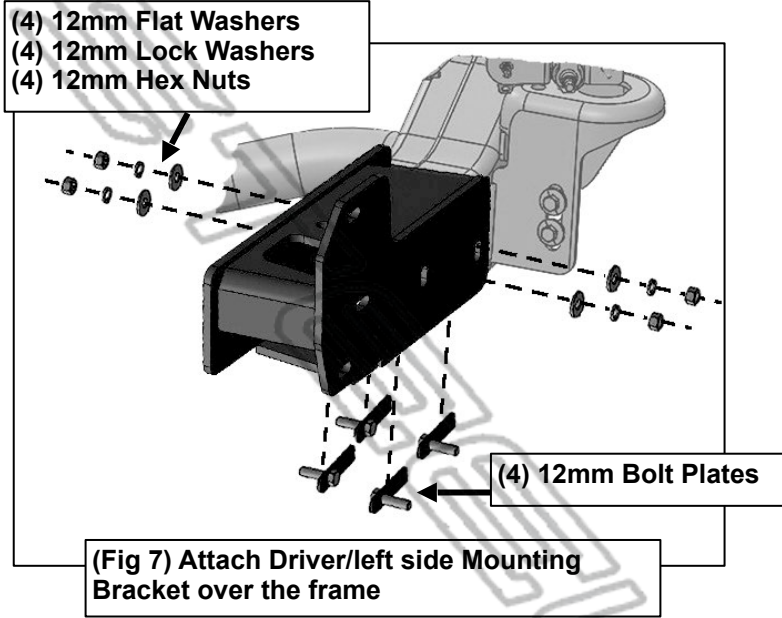



(Fig 11) Remove ACC Sensor, parking sensors and wiring harness from factory bumper, if equipped

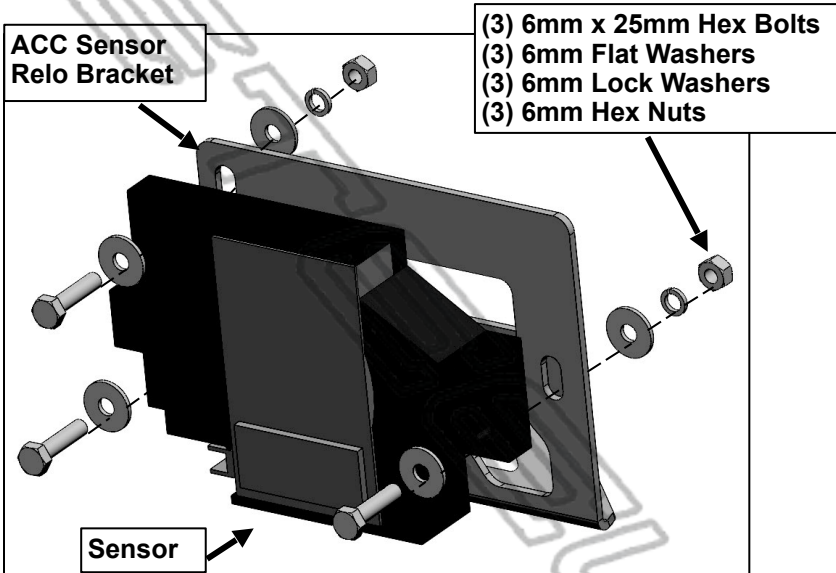

(Fig 12) Attach ACC sensor to ACC Sensor Relocation Bracket

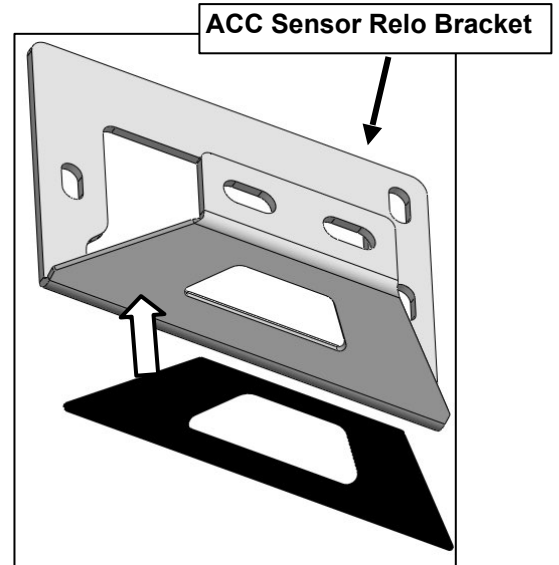

(Fig 13) Attach foam to bottom of ACC Sensor Relocation Bracket

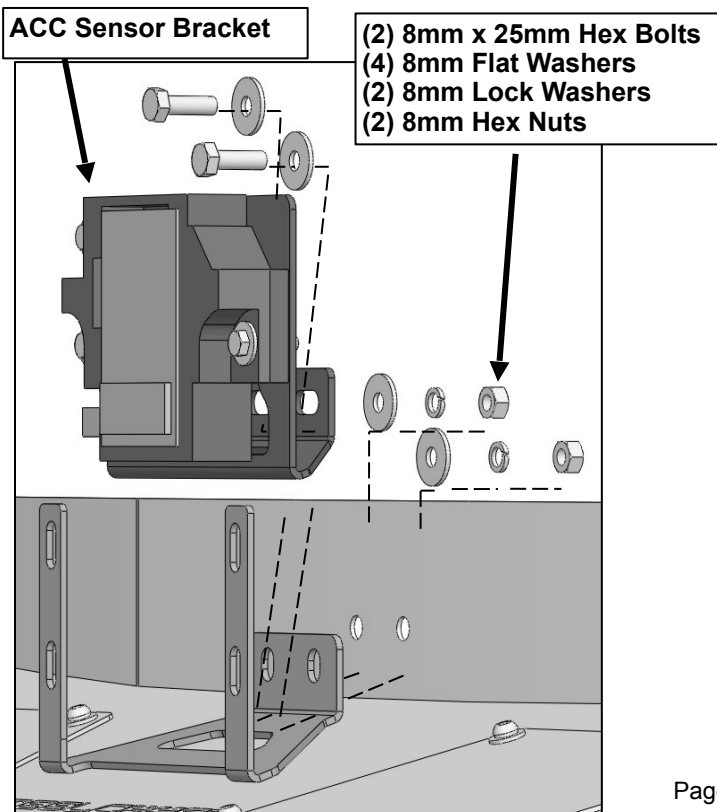

- (3) 6mm x 20mm Button Head Bolts
- (3) 6mm Flat Washers
- (3) 6mm Lock Washers
- (3) 6mm Hex Nuts

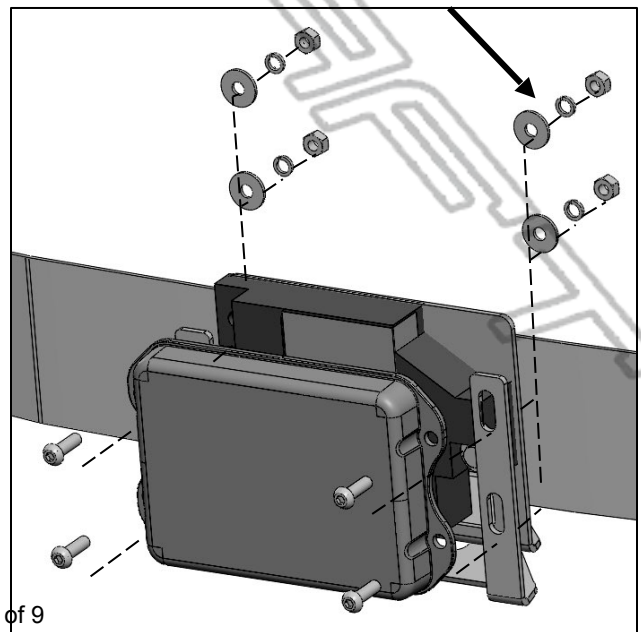

← ACC Cover Bracket

(Fig 14) Place ACC Sensor Relo Bracket within the ACC Cover Bracket and attach together to bumper

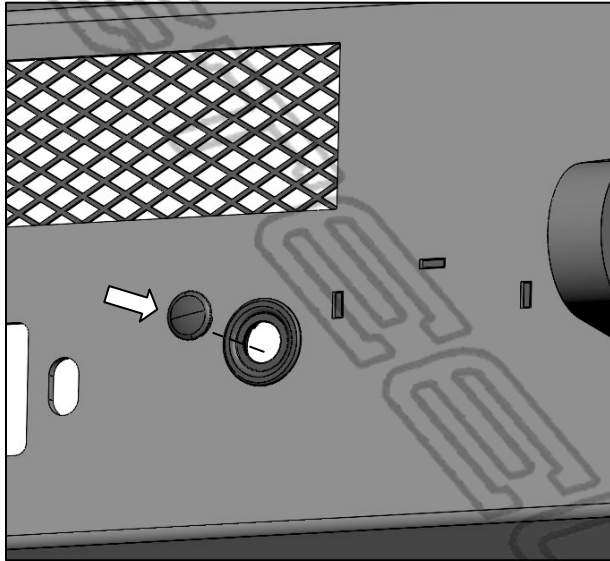

(Fig 16) Models without sensors: insert sensor plugs into the sensor hole (arrow)

WARNING! Do not crawl under bumper unless the bumper is properly supported on blocks or stands or the bumper may fall.

- (3) 12mm Hex Bolts
- (6) 12mm Flat Washers
- (3) 12mm Lock Washers
- (3) 12mm Hex Nuts

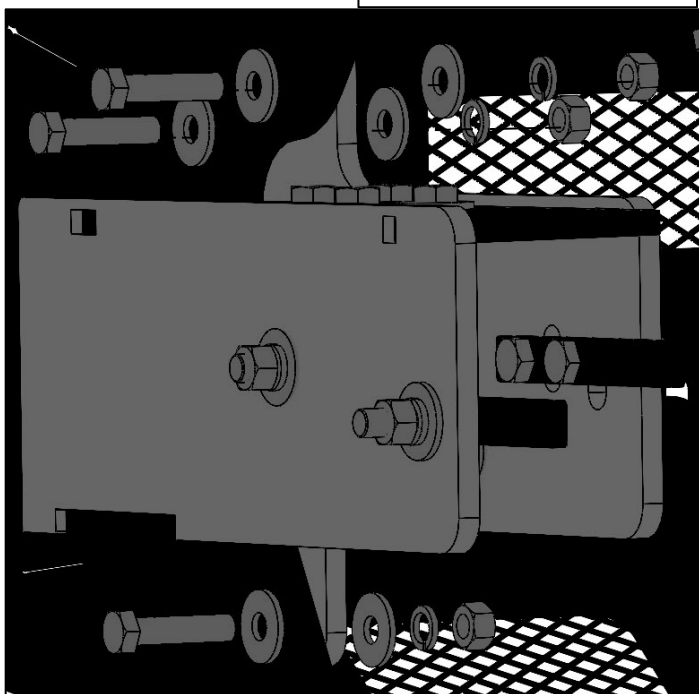

(Fig 15) Attach plastic ACC Cover to ACC Cover Bracket

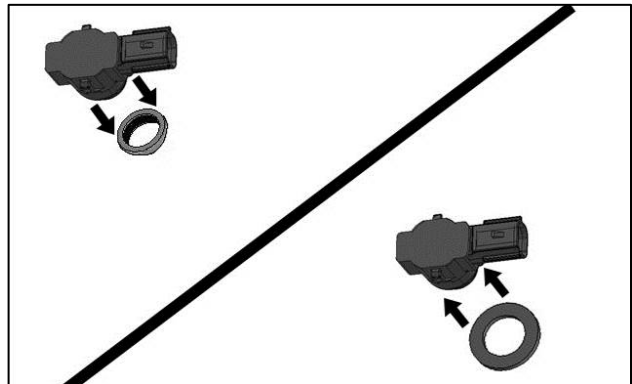

(Fig 17) Remove OE silicone seal from sensor. Slide large foam Seal over end of sensor

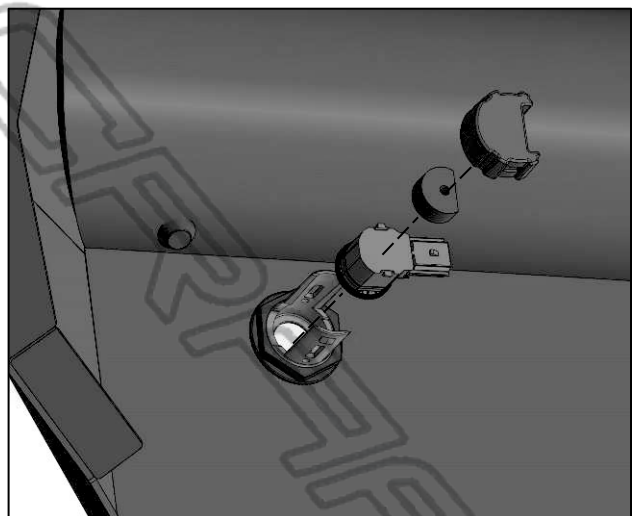

(Fig 18) Insert the sensor with seal into the sensor sleeve, followed by the foam spacer and retaining cap

Front

--- ---

(Fig 19) Attach Driver/left side of Bumper to Mounting Bracket

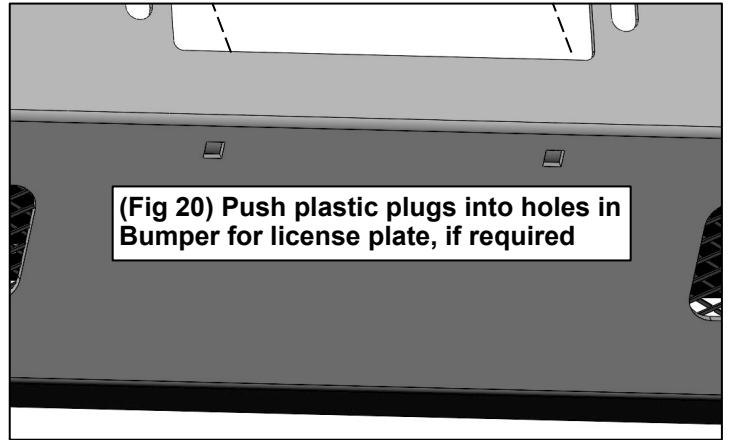

(Fig 20) Push plastic plugs into holes in Bumper for license plate, if required

