

PARTS LIST:

| | | | |
|----|---|---|-------------------------------------|
| 1 | Bull Bar | 8 | 12mm Lock Washers |
| 1 | Driver/Left Mounting Bracket | 4 | 12mm Hex Nuts |
| 1 | Passenger/Right Mounting Bracket | 2 | 10-1.5mm x 30mm Hex Bolts |
| 1 | Driver/Left Support Bracket | 4 | 10mm x 30mm OD x 2.5mm Flat Washers |
| 1 | Passenger/Right Support Bracket | 2 | 10mm Lock Washers |
| 2 | 8mm x 25mm Bolt Plates | 2 | 10mm Hex Nuts |
| 4 | 12-1.25mm x 40mm Special Fine Thread Hex Bolts | 2 | 8mm x 24mm OD x 2mm Flat Washers |
| 4 | 12-1.75mm x 30mm Coarse Thread Hex Bolts | 2 | 8mm Lock Washers |
| 12 | 12mm x 32mm OD x 3mm Flat Washers | 2 | 8mm Hex Nuts |

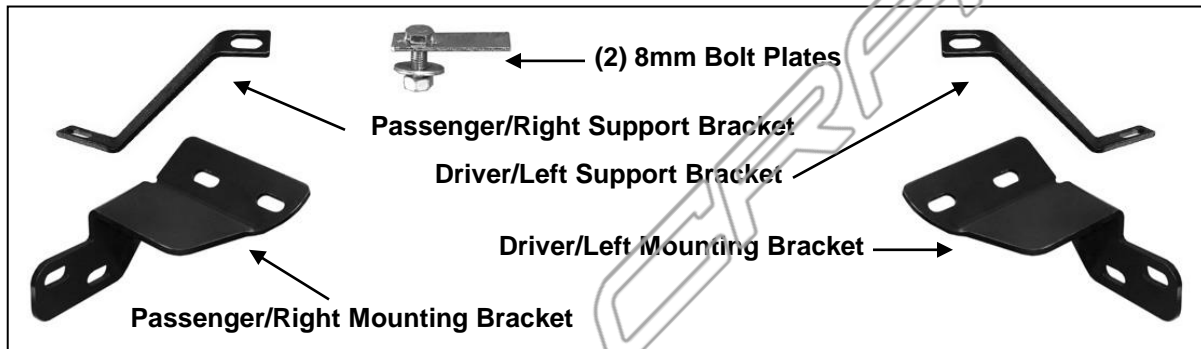

PROCEDURE:

REMOVE CONTENTS FROM BOX. VERIFY ALL PARTS ARE PRESENT. READ THE INSTRUCTIONS CAREFULLY. CUTTING AND DRILLING IS REQUIRED. It may be necessary to remove/relocate front license plate and license plate bracket. It is not required, but strongly recommended. If local/state law requires a license plate, a license plate relocation kit is available separately.

1. Start installation under the front bumper and carefully remove the large center plastic splash guard under the engine. **NOTE:** Depending on the model and year of vehicle, there may be several two-piece plastic push-in clips holding the splash guard up to the vehicle. Pry the center pin of the clip up with a small flat blade screwdriver and remove the entire clip. Pay close attention to the type and location of all factory hardware for reinstallation. Move the splash guard to a stable work area.
 - a. **Info for 2012-13 models only:** Also remove the plastic lower bumper air dam. It is not necessary to remove the plastic inner mounting plate for the air dam.
2. Locate and remove the two factory bolts securing the driver side frame support bracket to the front cross member, **(Figures 1A & 1B)**. Pull down on the support bracket just enough to slide the driver side Mounting Bracket between the frame bracket and the cross member, **(Figure 2)**. **VERY IMPORTANT:** Only install one Mounting Bracket at a time. Do not pull down too hard or you may bend the frame bracket. If more room is required to insert the Mounting Bracket, loosen but do not remove the large hex bolt at the end of the frame support bracket, **(Figure 2)**.
 - a. **Info for 2012-13 models only:** Slide the Bracket up in position as previously described to check fitment, **(Figure 2)**. Note that the plastic mounting plate attached directly to the body for the air dam will need to be trimmed slightly to clear the Brackets. Remove as little material as possible to install the Bracket. **IMPORTANT:** Do not cut off any of the mounting tabs for the air dam.
3. Line up the (2) holes in the Mounting Bracket with the holes in the factory support bracket. Replace the factory hex bolts with the included longer (2) 12-1.25mm x 40mm Special Fine Thread Hex Bolts, (2) 12mm Lock Washers and (2) 12mm Flat Washers, **(Figure 3)**. Snug but do not tighten all hardware at this time.
4. Repeat **Steps 2 - 3** for the passenger side Mounting Bracket installation.
 - a. **Info for 2012-13 models only:** Hold the lower air dam up in approximate position against the bottom of the (2) Mounting Brackets. Mark the location of the Brackets onto the underside of the air dam.

**BULL BAR
2009-13 HONDA PILOT**

Insert Mounting Bracket between frame support and cross member (2012-13 passenger side pictured)

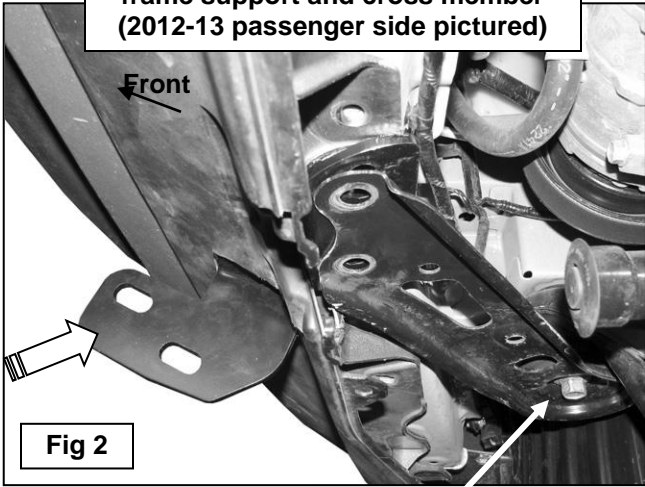

Fig 2

Loosen but do not remove this factory bolt if needed

2012-13 installation pictured with air dam in place for instruction purposes only

2012-13 driver side pictured

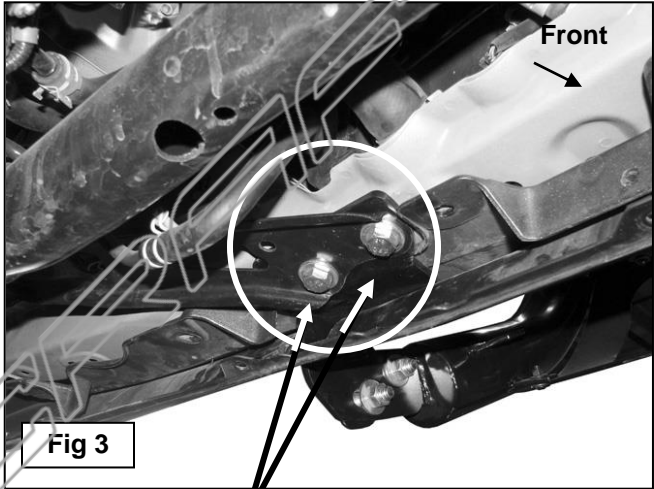
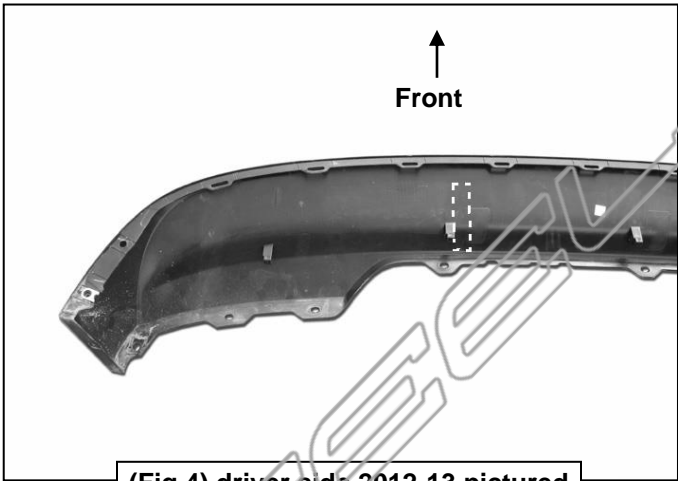

Fig 3

- (2) 12-1.25mm x 40mm Special Fine Thread Hex Bolts
- (2) 12mm Lock Washers
- (2) 12mm Flat Washers



(Fig 4) driver side 2012-13 pictured

Do not cut through the front or back edge of the air dam

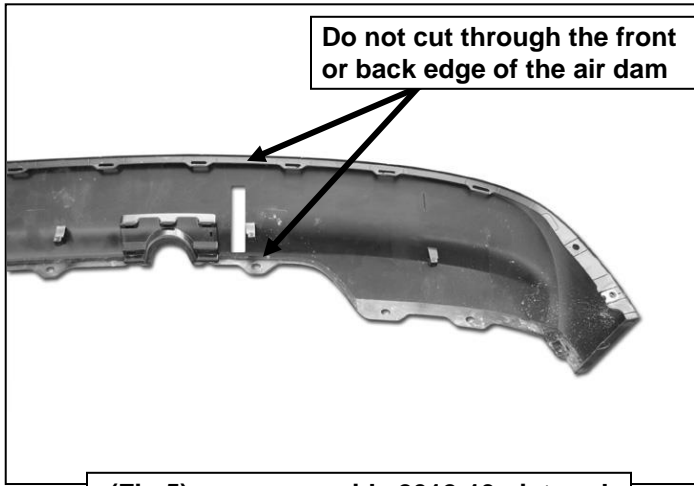

(Fig 5) passenger side 2012-13 pictured

Do not cut through the front or back edge of the air dam

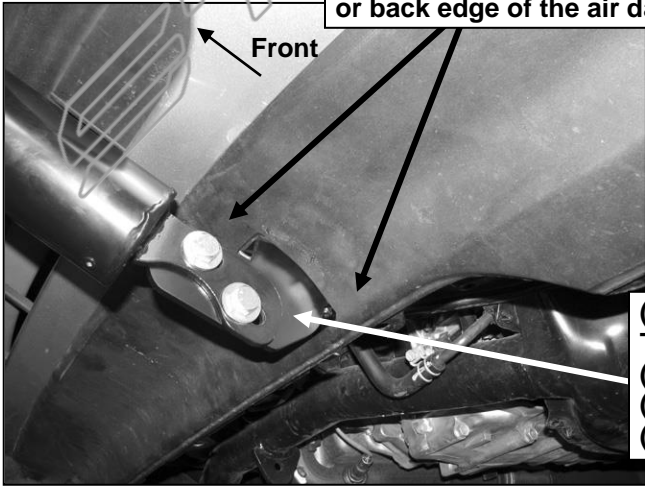

(Fig 6) driver side 2012-13 pictured

- (2) 12-1.75mm x 30mm Coarse Thread Hex Bolts
- (2) 12mm Lock Washers
- (4) 12mm Flat Washers
- (2) 12mm Hex Nuts

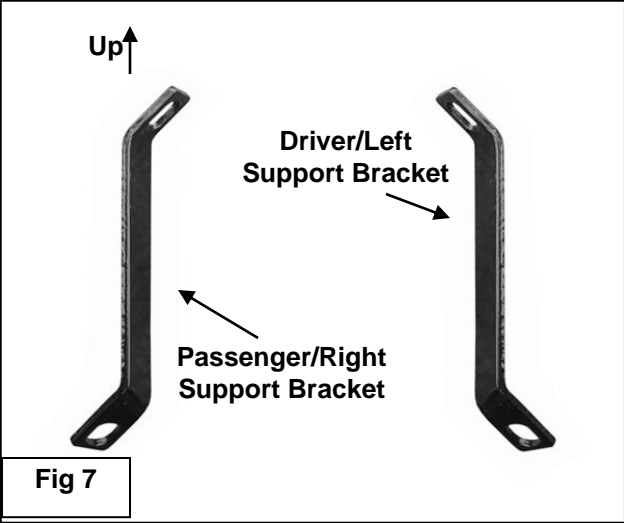

Mark the Bracket location onto the bottom of the crossmember. Temporarily remove the Bull Bar and Support Brackets. Check backside of crossmember for clearance before drilling. (driver side pictured from below)

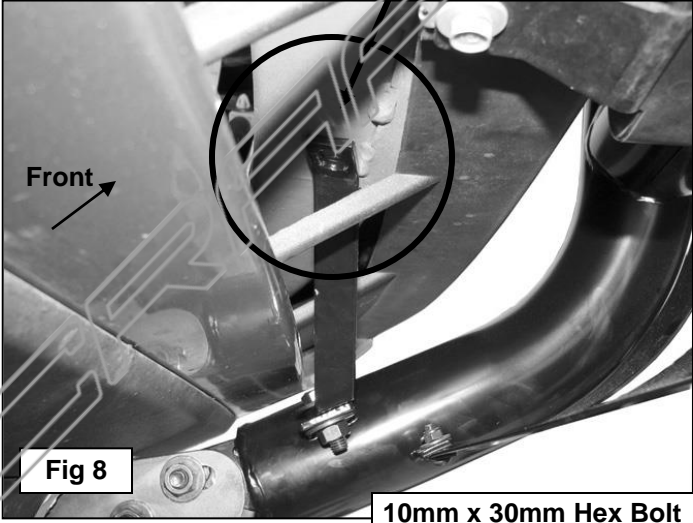

Drill a 3/8" hole through the cross member behind the front bumper. (driver side pictured from below)

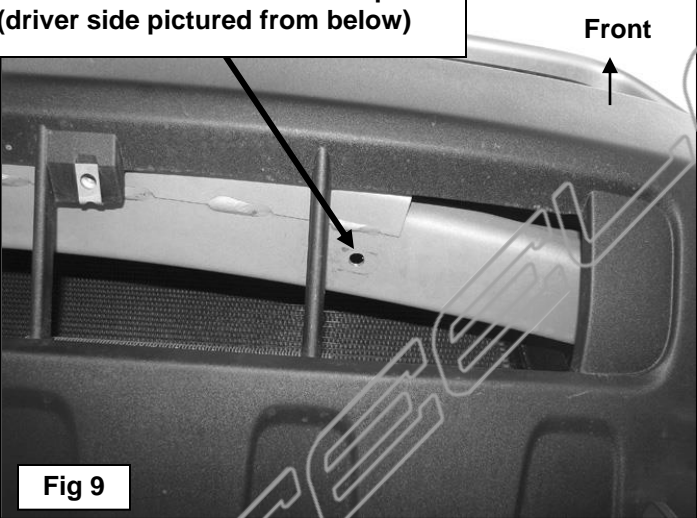

10mm x 30mm Hex Bolt
10mm Lock Washer
(2) 10mm Flat Washers
10mm Hex Nut

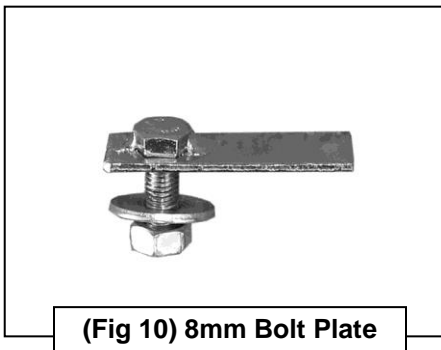
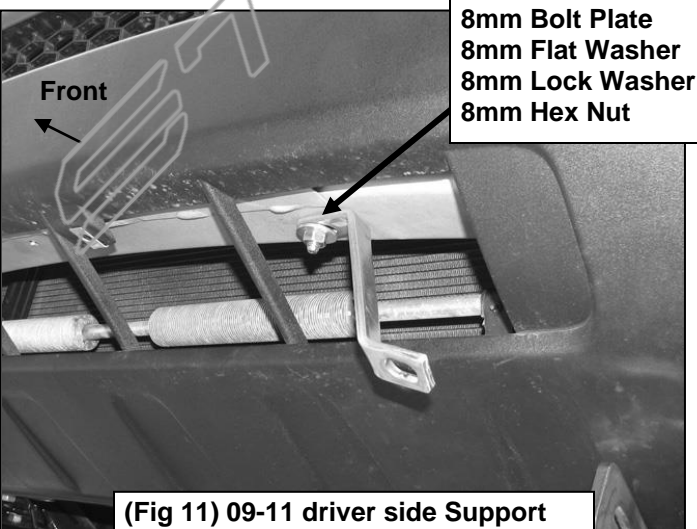

**BULL BAR
2009-13 HONDA PILOT**

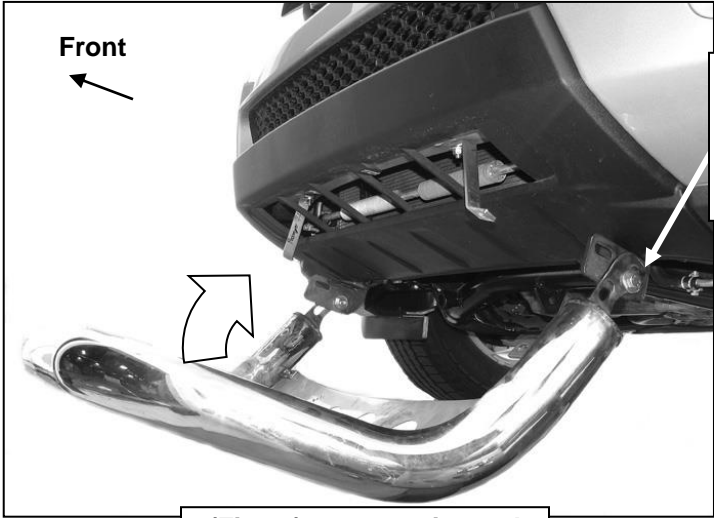

- (2) 12-1.75mm x 30mm Coarse Thread Hex Bolts
- (4) 12mm Flat Washers
- (2) 12mm Lock Washers
- (2) 12mm Hex Nuts

(Fig 12) 2009-11 pictured

Install and align the Bull Bar as per instructions, tighten all hardware before marking the area on the splash guard to cut for clearance. Cut along dotted line.

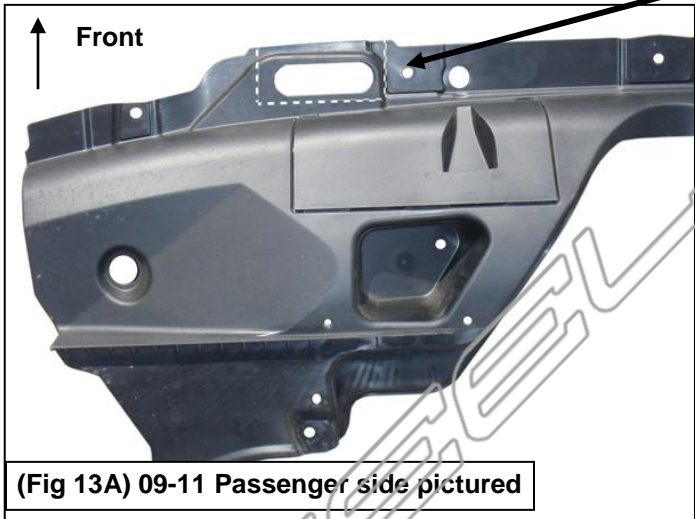

(Fig 13A) 09-11 Passenger side pictured

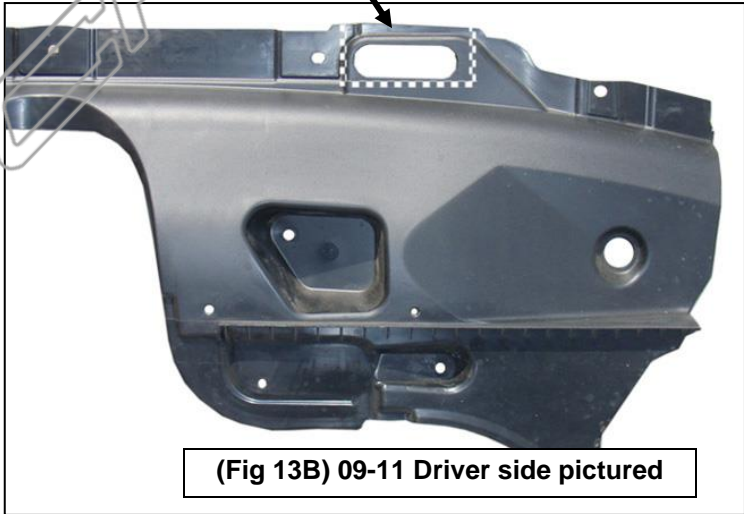

(Fig 13B) 09-11 Driver side pictured



Complete installation