

INSTALLATION INSTRUCTIONS

**HD SIDE STEPS
07-16 WRANGLER 4DR**

Parts List

1	Driver/Left HD Side Step Assembly	6	8-1.25mm x 35mm Hex Bolts
1	Passenger/Right HD Side Step Assembly	6	8mm x 28mm OD x 3mm Flat Washers
6	10mm Nut Plates	6	8mm Lock Washers
6	10-1.5mm x 35mm Hex Bolts	6	6-1.0mm x 25mm Hex Bolts
6	10mm x 34mm OD x 3mm Flat Washers	12	6mm x 22mm OD x 2mm Flat Washers
6	10mm Lock Washers	6	6mm Nylon Lock Nuts

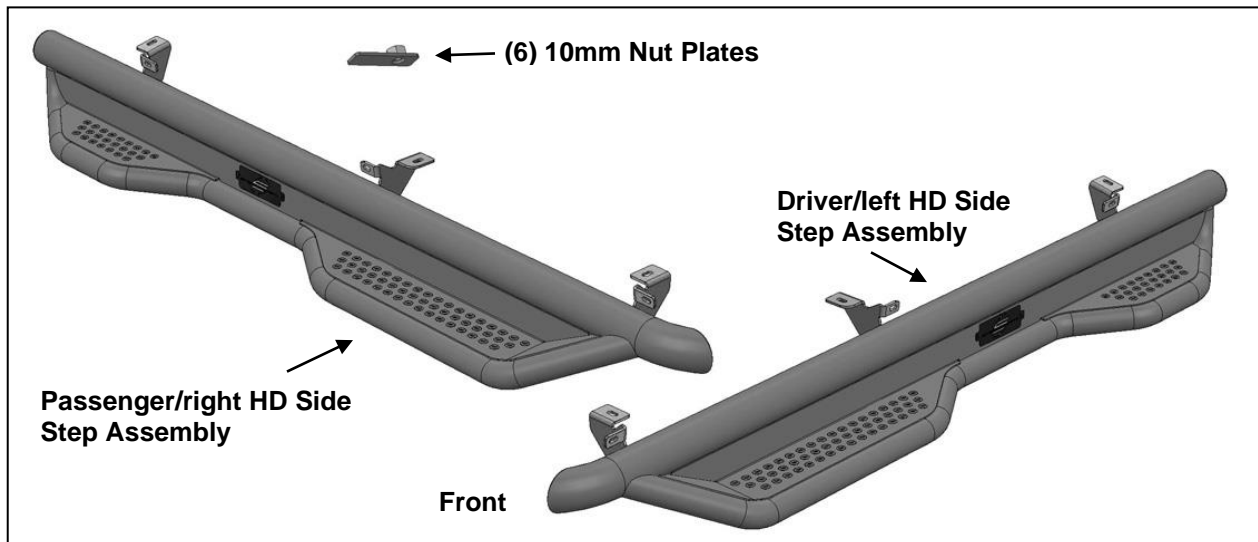

PROCEDURE:

1. REMOVE CONTENTS FROM BOX. VERIFY ALL PARTS ARE PRESENT. READ INSTRUCTIONS CAREFULLY BEFORE STARTING INSTALLATION. FACTORY INSTALLED OR AFTERMARKET "ROCK RAILS," SIDE STEPS OR RUNNING BOARDS MUST BE REMOVED.
2. Start installation along the side of the passenger side of the vehicle. Locate the (3) pairs of factory mounting holes along the pinch weld, **(Figure 1)**. The top mounting location for the Side Step Assembly will be between and behind the two factory holes in the pinch weld, **(Figure 2)**.
3. Determine if the vehicle has an open floor panel, **(Figure 2)**, or threaded holes in the floor panel at the (3) mounting locations, **(Figure 5)**. **NOTE:** Depending on model year, vehicles may be equipped with both "open floor channel" and threaded mounting holes. Remove any insulation that may be covering the mounting locations.

Vehicles with "open" mounting location:

- a. Insert (1) 10mm Nut Plate into the large square opening in the floor panel, **(Figures 3 & 4)**.
- b. Line up the 10mm Nut with the hole in line between the two holes in the pinch weld.
- c. Repeat to install remaining 10mm Nut Plates as required.

Vehicles with factory threaded hole in floor panel, **(Figure 5)**, proceed to **Step 4**:

4. With assistance, hold the passenger side HD Side Step up against the bottom of the vehicle. Attach each top mounting tab to the 10mm Nut Plate as required with (1) 10mm x 35mm Hex Bolt, (1) 10mm Lock Washer and (1) 10mm Flat Washer, **(Figure 6)**. Attach the mounting tab to any threaded hole in the floor panel with (1) 8mm x 35mm Hex Bolt, (1) 8mm Lock Washer and (1) 8mm Flat Washer, **(Figure 6)**. Snug but do not fully tighten hardware at this time. Repeat appropriate procedure as required at all mounting locations.
5. Push the support tabs on the Side Step assembly outward to the back of the pinch weld. Attach each tab to the back of the pinch weld with (1) 6mm x 25mm Hex Bolt, (2) 6mm Flat Washers and (1) 6mm Nylon Lock Nut, **(Figure 6)**. Snug all hardware but do not tighten at this time. Repeat for all mounting locations.
6. Adjust and level the HD Side Step and tighten all hardware.
7. Repeat **Steps 2—6** for driver/left Side Step installation.
8. Do periodic inspections to the installation to make sure that all hardware is secure and tight.

To protect your investment, wax this product after installing. Regular waxing is recommended to add a protective layer over the finish. Do not use any type of polish or wax that may contain abrasives that could damage the finish.
For powder coated finishes: Mild soap may be used to clean Side Step.

Passenger Side Installation Pictured

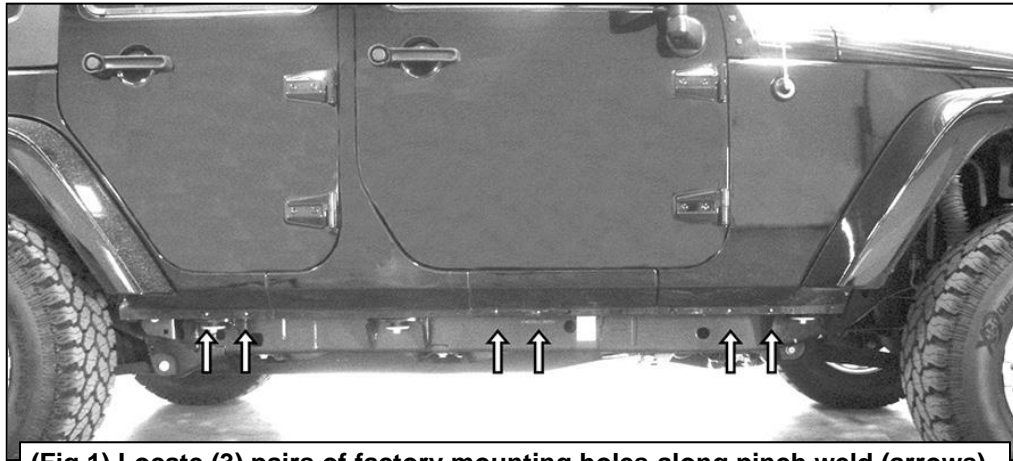

(Fig 1) Locate (3) pairs of factory mounting holes along pinch weld (arrows)

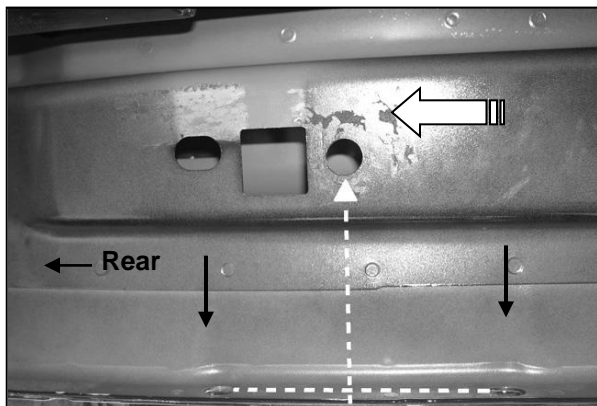

(Fig 2) 2007-10 driver side rear mounting location pictured from below. Locate the holes in the pinch weld first to determine correct mounting hole for 10mm Nut Plate

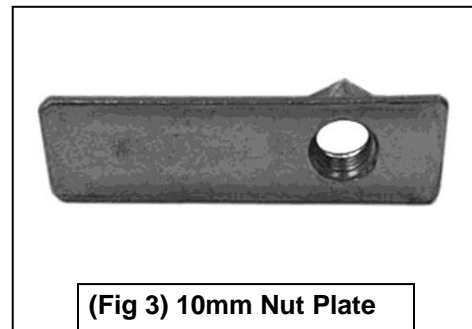

(Fig 3) 10mm Nut Plate

Insert 10mm Nut Plate into opening and line up nut with mounting hole

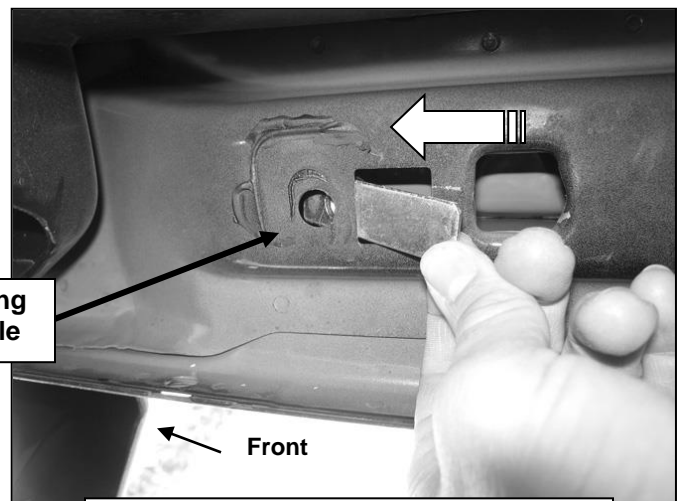

(Fig 4) Opening in floor frame channel (passenger side-front pictured)

Passenger Side Installation Pictured

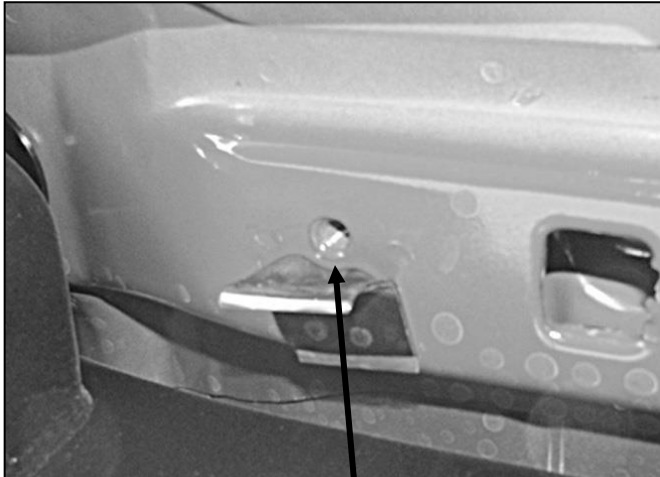

(Fig 5) 8mm threaded hole in "closed" floor frame channel (passenger side-front pictured for example)



Complete Installation

