



INSTALLATION INSTRUCTIONS

**SIDE ARMOR
2018 JEEP WRANGLER JL 4 DOOR**

**SIDE ARMOR
2018 JEEP WRANGLER JL 4 DOOR**

PARTS LIST:

1	Driver/left Side Armor	16	8mm x 24mm x 2mm Flat Washers
1	Passenger/right Side Armor	8	8-1.25mm Nylon Lock Nuts
6	8-1.25mm x 35mm Hex Bolts	4	6-1.0mm x 25mm Hex Bolts
8	8-1.25mm x 25mm Hex Bolts	8	6mm x 22mm x 2mm Flat Washers
6	8mm Lock Washers	4	6-1.0mm Nylon Lock Nuts
6	8mm x 28mm x 3mm Flat Washers		

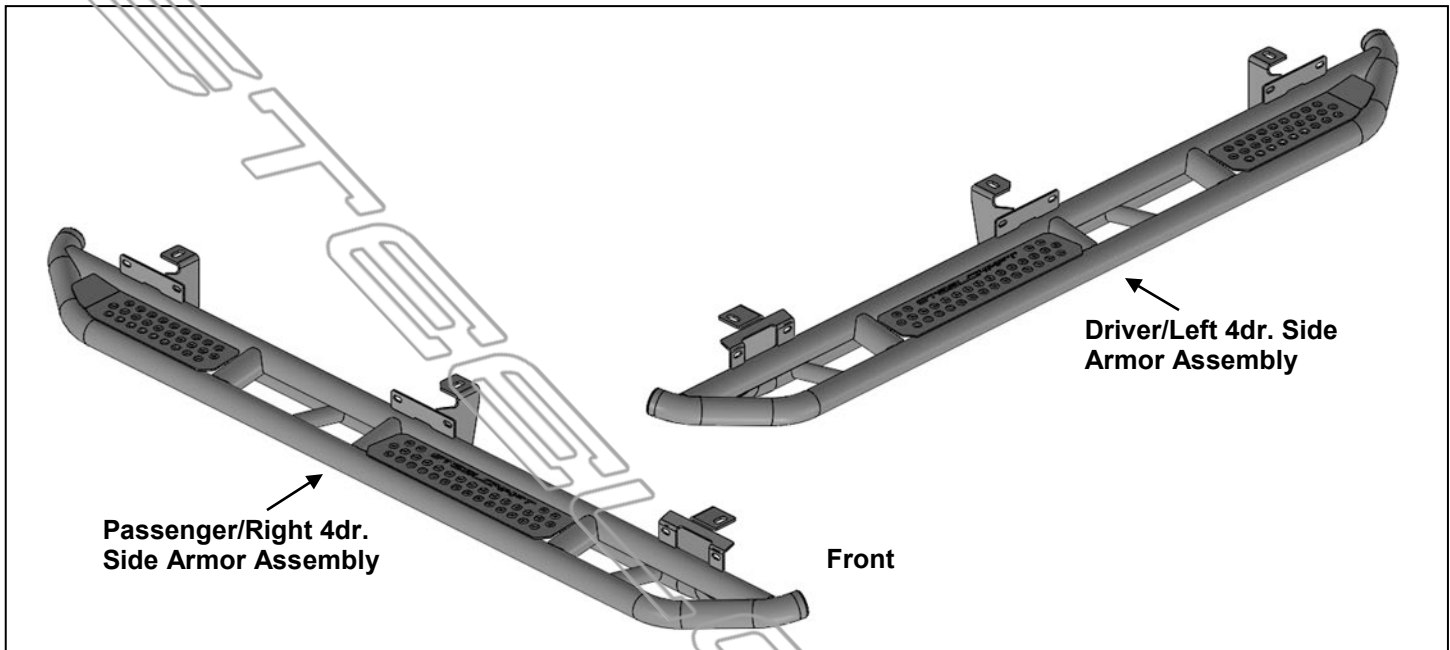

PROCEDURE: REMOVE CONTENTS FROM BOX. VERIFY ALL PARTS ARE PRESENT. READ INSTRUCTIONS CAREFULLY. FACTORY INSTALLED OR AFTERMARKET "ROCK RAILS," SIDE STEPS OR RUNNING BOARDS MUST BE REMOVED. ASSISTANCE IS HIGHLY RECOMMENDED.

1. Start installation on the passenger/right side of the vehicle. Locate the (3) pairs of factory mounting holes along the pinch weld, **(Figure 1)**. The mounting brackets on the Side Armor attach to the holes in the pinch weld and the small factory threaded hole directly behind the pinch weld, **(Figures 2—4)**.
2. With assistance, hold the Passenger/right Side Armor up in place against the back of the pinch weld. Line up the (3) welded brackets with the (6) factory holes in the pinch weld, **(Figures 5—9)**.
 - a. Bolt the front welded bracket to the **back** of the pinch weld with (1) 6mm Hex Bolt, (2) 6mm Flat Washers and (1) 6mm Nylon Lock Nut. Use (1) 8mm x 25mm Hex Bolt, (2) 8mm Flat Washers and (1) 8mm Nylon Lock Nut to finish installing the front welded bracket. **NOTE:** Use the 6mm hardware on the smaller holes in the pinch weld. Use the 8mm hardware on the larger holes in the pinch weld.
 - b. Bolt the center welded bracket to the **back** of the pinch weld with (2) 8mm x 25mm Hex Bolts, (4) 8mm Flat Washers and (2) 8mm Nylon Lock Nuts.
 - c. Repeat **Step 2a** to install the rear welded bracket to the **back** of the pinch weld.
 - d. Leave hardware loose at this time.
 - e. **NOTE:** Insert Bolts from outside the pinch weld and out through the Bracket.
3. Bolt each top tab on the Side Armor to the vehicle with the included (1) 8mm x 35mm Hex Bolt, (1) 8mm Lock Washer and (1) 8mm Flat Washer, **(Figures 5—9)**. Repeat for all locations.
4. Level and adjust the Side Armor and tighten all hardware.
5. Repeat **Steps 2—5** for Passenger Side Armor installation.
6. Do periodic inspections to the installation to make sure that all hardware is secure and tight.

To protect your investment Do not use any type of polish or wax that may contain abrasives that could damage the finish. Mild soap may be used to clean the Side Armor.

**SIDE ARMOR
2018 JEEP WRANGLER JL 4 DOOR**

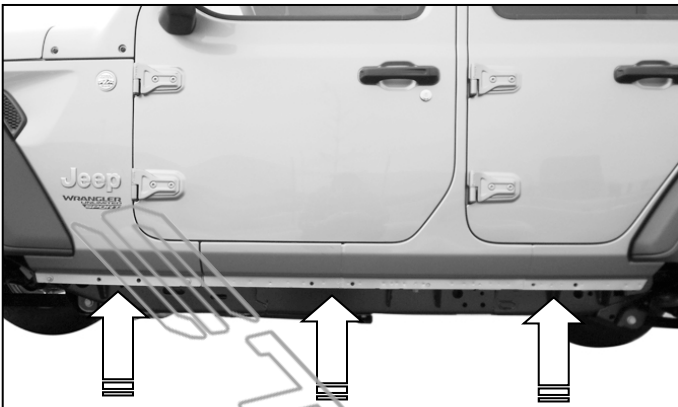

(Fig 1) Locate the (3) factory pair of holes along the pinch weld (Driver/left side pictured)

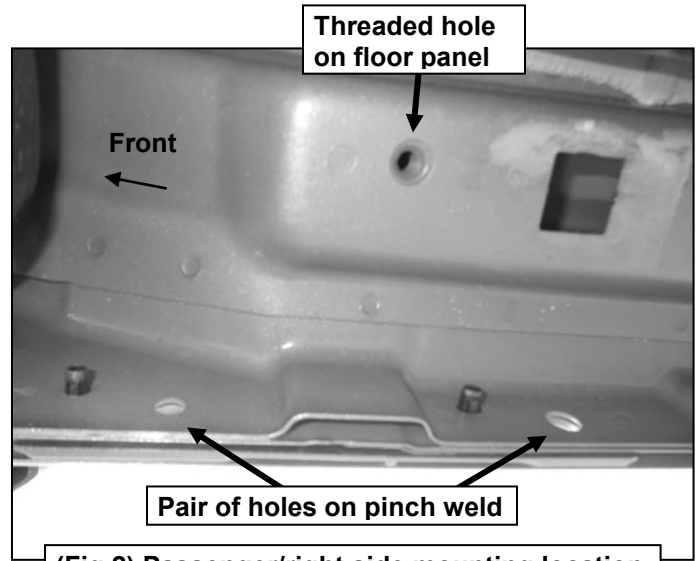

(Fig 2) Passenger/right side mounting location

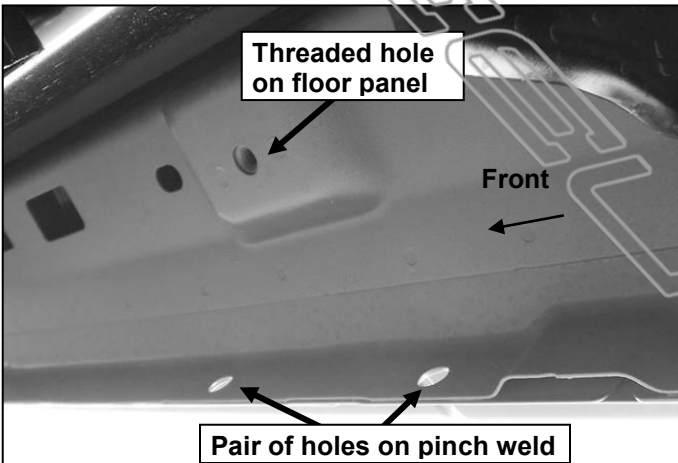

(Fig 3) Passenger/right center mounting location

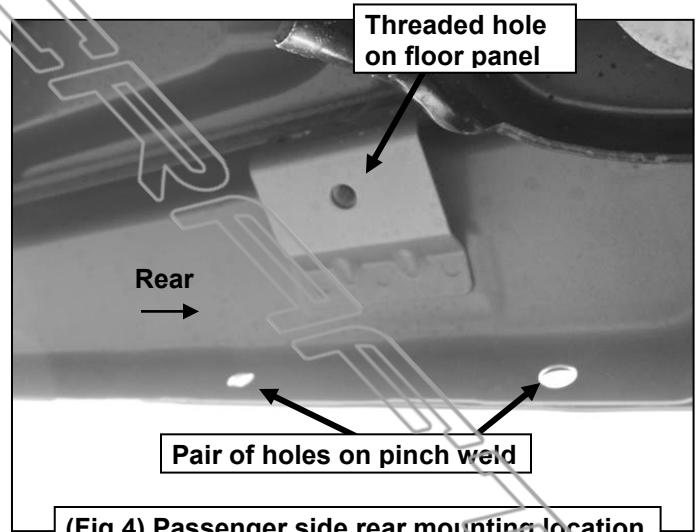

(Fig 4) Passenger side rear mounting location

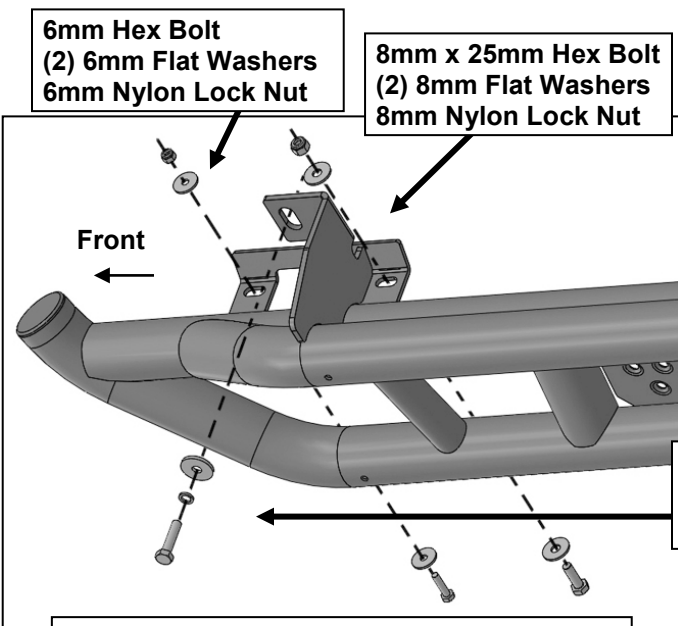

(Fig 5) Passenger side front welded Bracket attached to pinch weld and inner floor panel

**SIDE ARMOR
2018 JEEP WRANGLER JL 4 DOOR**

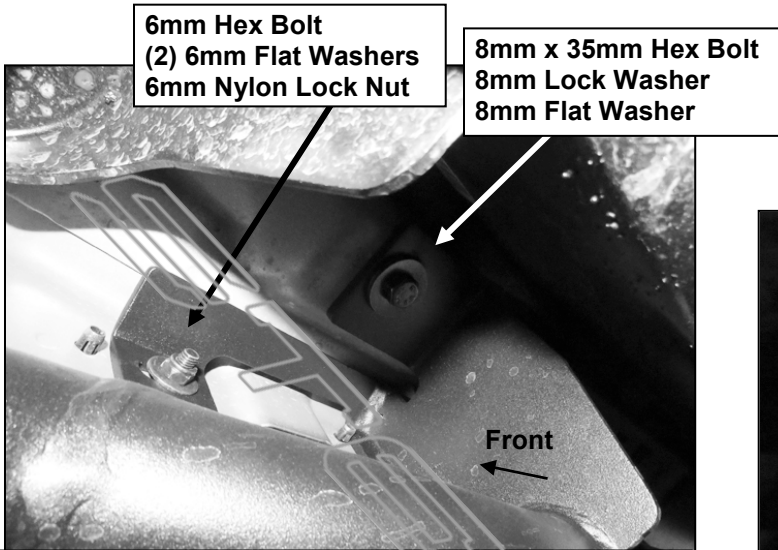

(Fig 6) Passenger side front welded Bracket installed

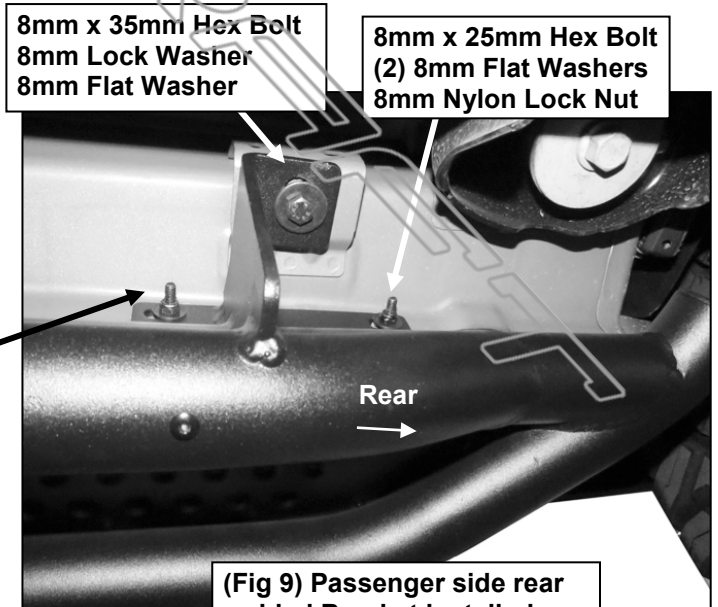
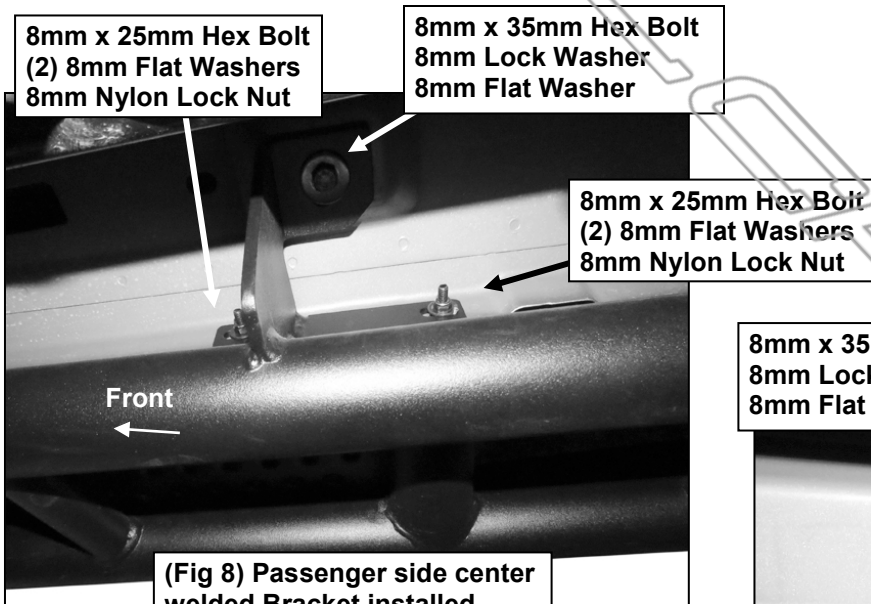
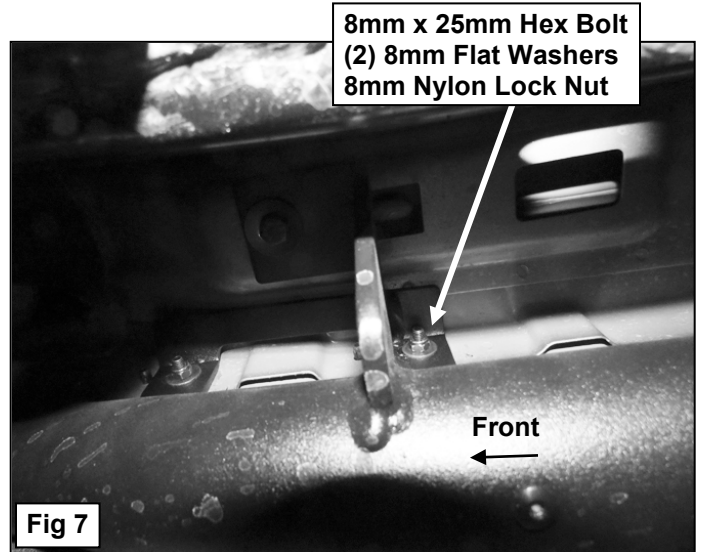

6mm Hex Bolt
(2) 6mm Flat Washers
6mm Nylon Lock Nut