

# **INSTALLATION INSTRUCTIONS**

**HD WHEEL TO WHEEL SIDE STEP**

**99-16 FORD SUPER DUTY SUPER CREW 6.5FT STD BED**

STEELCRAFT

**PARTS LIST:**

1	Driver/Left Heavy Duty Side Step	36	10mm x 27mm OD x 2mm Flat Washers
1	Passenger/Right Heavy Duty Side Step	24	10mm Lock Washers
12	10mm Clip-Nuts	12	10-1.5mm Hex Nuts
24	10-1.5mm x 30mm Hex Bolts		

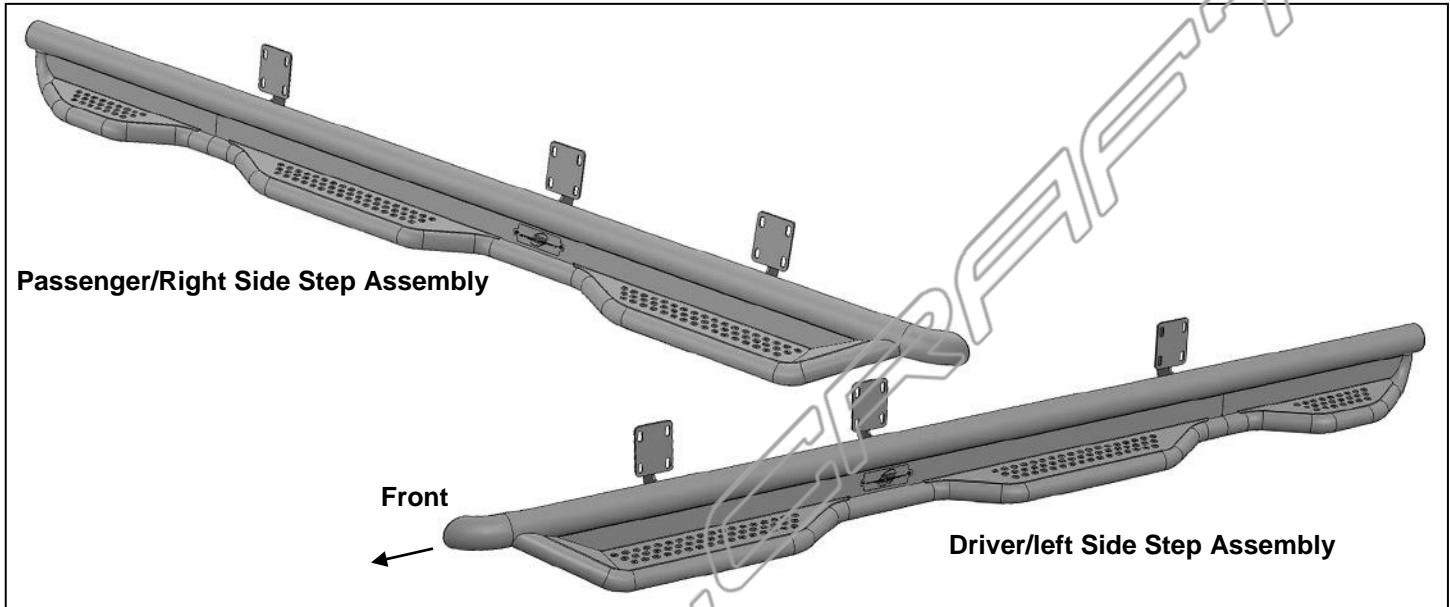

**PROCEDURE:**

**REMOVE CONTENTS FROM BOX. VERIFY ALL PARTS ARE PRESENT. READ INSTRUCTIONS CAREFULLY. ASSISTANCE IS HIGHLY RECOMMENDED.**

- Starting on the driver/left side of the vehicle, locate the factory mounting locations along the inner body panel. There are (5) mounting locations along the body, installation will use the 2nd, 3rd and 5th mounting locations. **NOTE:** To locate the mounting locations, first locate the (5) pairs of holes along the pinch weld. Next, locate the small rectangular hole and (2) small round holes in the inner body panel directly above the holes in the pinch weld, **(Figure 1)**. If necessary, place the driver/left Side Step assembly in position to help determine correct mounting locations.
- Move to the 2nd mounting location from the front wheel opening. Slide (1) 10mm Clip Nut into the rectangular opening with the nut towards the inside. Line up the threaded nut on the clip with the round hole, **(Figure 2, 3 & 4)**. Repeat to install a second Clip Nut in the remaining hole.
- Continue along the cab to the 3rd mounting location. Repeat **Steps 1 & 2** to install the (2) 10mm Clip Nuts, **(Figure 3)**.
- Continue along the cab to the last, (5th), mounting location at the back of the cab. Repeat **Steps 1 & 2** to install the (2) 10mm Clip Nuts in the rear mounting location **(Figure 3)**
- With assistance, hold the driver/left Side Step assembly up in place against the inner body panel. Attach the Side Step to the (6) Clip Nuts with the included (6) 10mm x 30mm Hex Bolts, (6) 10mm Lock Washers and (6) 10mm Flat Washers, **(Figures 4—7)**. Leave hardware loose.
- Align the bottom holes in the Side Step mounts with the (6) holes along the pinch weld. Bolt the Side Step to the pinch weld with the included (6) 10mm x 30mm Hex Bolts, (12) 10mm Flat Washers, (6) 10mm Lock Washers and (6) 10mm Hex Nuts, **(Figures 4—7)**. **NOTE:** Insert the bolts with flat washers up from the bottom of the pinch weld and through the Bracket.
- Level and adjust the Side Step and tighten all hardware.
- Repeat **Steps 1—7** for passenger/right Side Step installation.
- Do periodic inspections to the installation to make sure that all hardware is secure and tight.

To protect your investment, wax this product after installing. Regular waxing is recommended to add a protective layer over the finish. Do not use any type of polish or wax that may contain abrasives that could damage the finish. Use only mild soap to clean the Side Step.

### Driver/left Side Installation Pictured

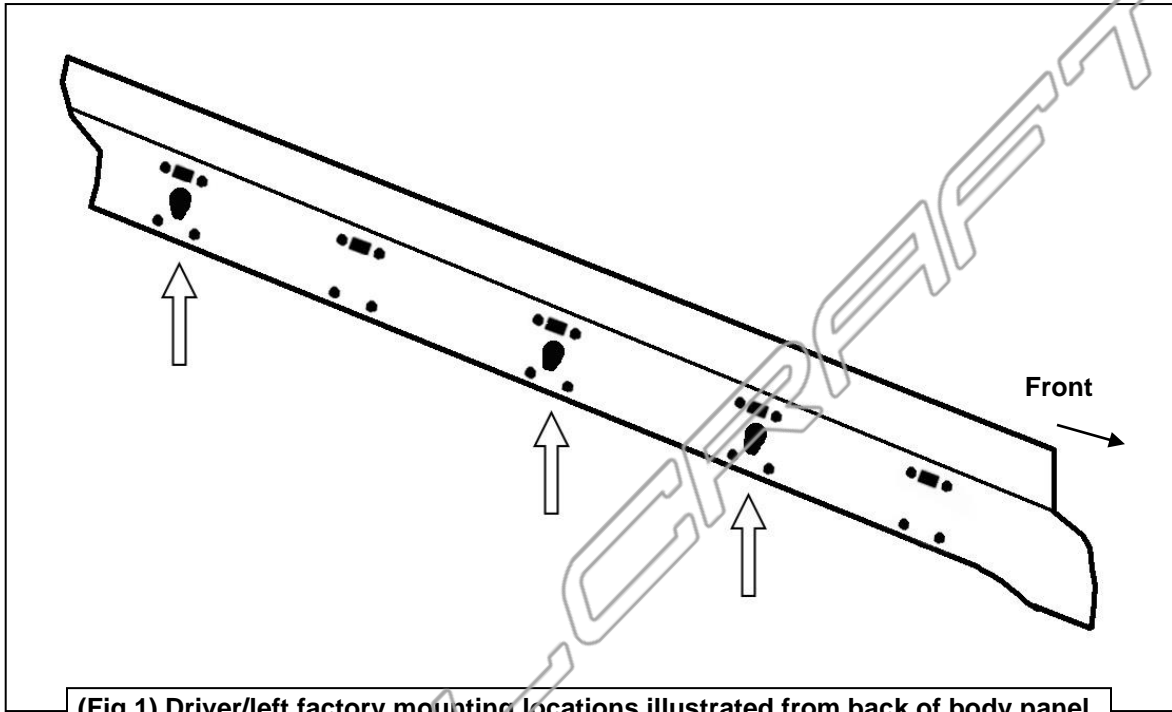

(Fig 1) Driver/left factory mounting locations illustrated from back of body panel

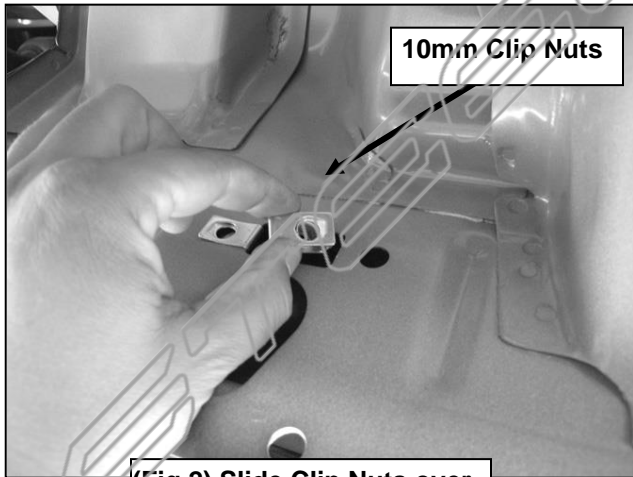

(Fig 2) Slide Clip Nuts over round holes in body panel

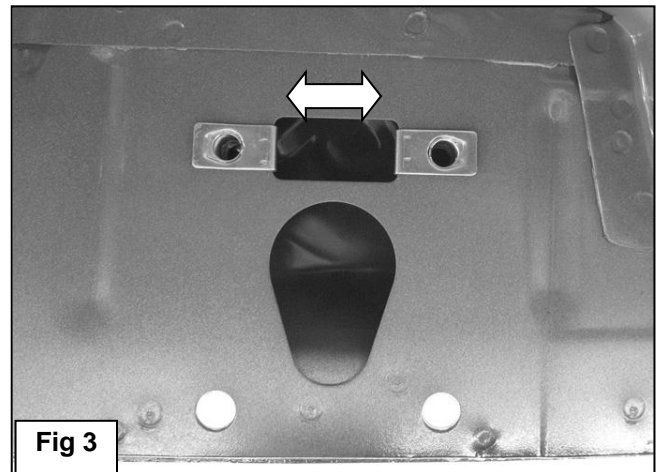
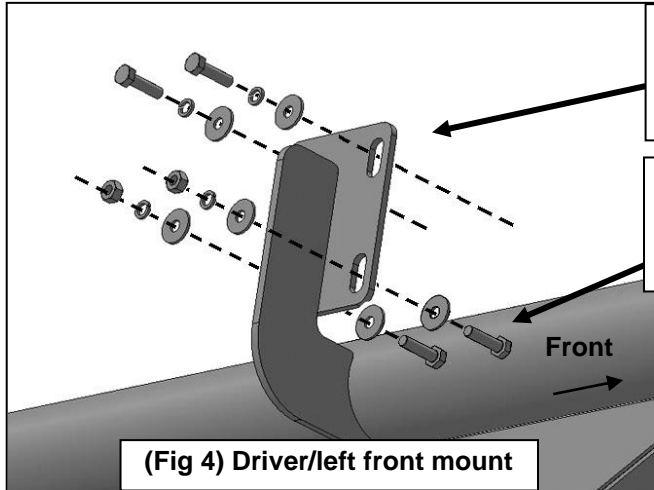

Fig 3

### Driver/left Side Installation Pictured



- 10mm Clip Nut
- 10mm x 30mm Hex Bolt
- 10mm Lock Washer
- 10mm Flat Washer

- 10mm x 30mm Hex Bolt
- (2) 10mm Flat Washers
- 10mm Lock Washer
- 10mm Hex Nut

- 10mm Clip Nut
- 10mm x 30mm Hex Bolt
- 10mm Lock Washer
- 10mm Flat Washer

(Fig 4) Driver/left front mount

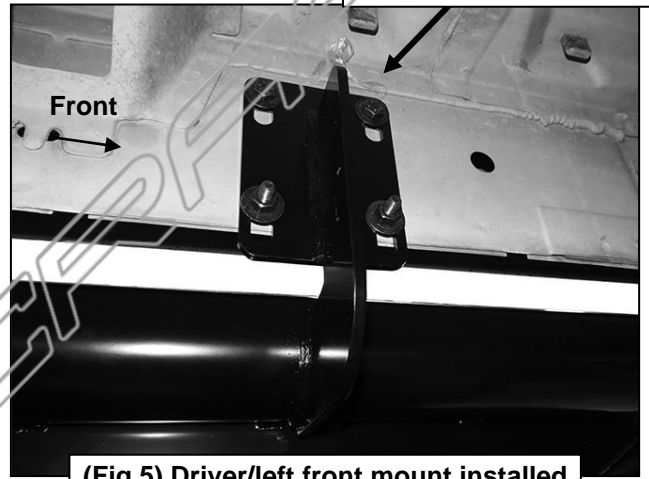

(Fig 5) Driver/left front mount installed

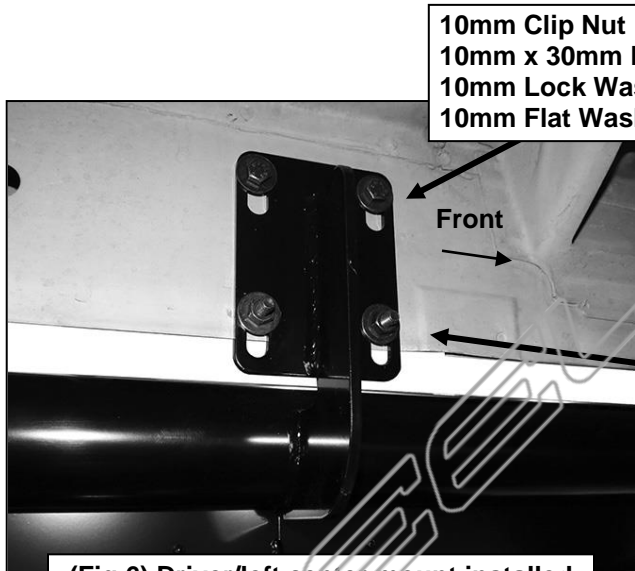

- 10mm Clip Nut
- 10mm x 30mm Hex Bolt
- 10mm Lock Washer
- 10mm Flat Washer

(Fig 6) Driver/left center mount installed

- 10mm x 30mm Hex Bolt
- (2) 10mm Flat Washers
- 10mm Lock Washer
- 10mm Hex Nut

- 10mm x 30mm Hex Bolt
- (2) 10mm Flat Washers
- 10mm Lock Washer
- 10mm Hex Nut



(Fig 7) Driver/left rear mount installed



Complete installation