

**HD WHEEL TO WHEEL SIDE STEP
2010-17 25-3500 DODGE RAM CREW CAB 8ft BED**

PARTS LIST:

1	Driver/Left HD Running Board	24	8mm x 24mm OD x 2mm Flat Washers
1	Passenger/Right HD Running Board	12	8mm Lock Washers
3	Driver/Left front, passenger center/rear Support Brackets	6	8mm-1.25 Hex Nuts
3	Passenger/Right front, driver center/rear Support Brackets	6	8mm-1.25 Nylon Lock Nuts
6	8mm Bolt/Nut Plates	12	6mm-1.0 x 25mm Hex Bolts
6	8mm Plastic Retainers	24	6mm x 22mm x 2mm Flat Washers
18	8mm-1.25 x 30mm Hex Bolts	12	6mm Nylon Lock Nuts

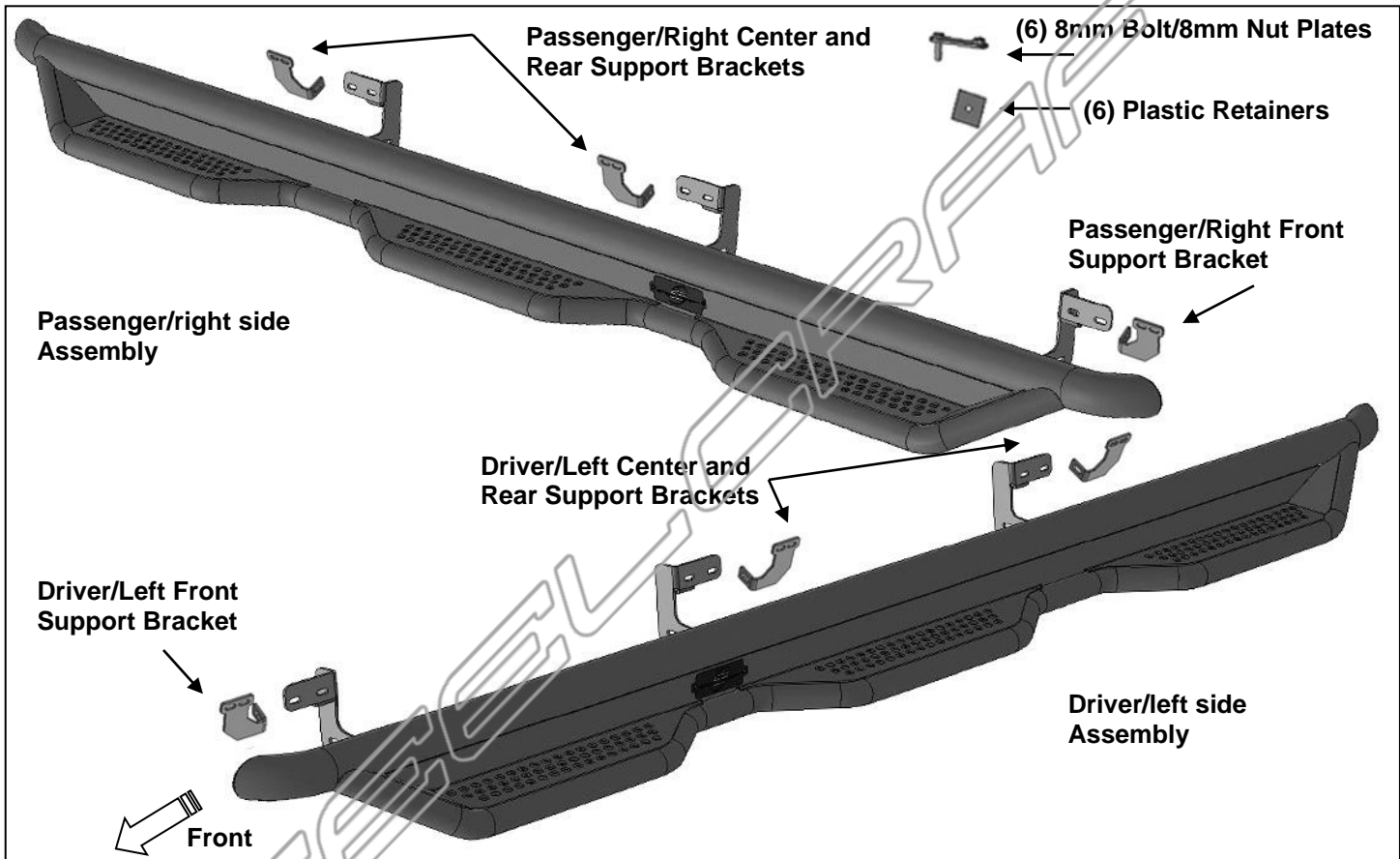

PROCEDURE:

REMOVE CONTENTS FROM BOX. VERIFY ALL PARTS ARE PRESENT. READ INSTRUCTIONS CAREFULLY BEFORE STARTING INSTALLATION. DRILLING MAY BE REQUIRED. ASSISTANCE IS HIGHLY RECOMMENDED.

- Starting at the passenger side of the vehicle, locate the (3) mounting locations along the inner body panel. **(Figures 1 & 9)**. Remove any sealing tape covering the factory holes.
- Determine the correct procedure to attach the brackets on the HD Side Step assembly to your model/year. **NOTE:** Vehicles may be equipped with threaded inserts in any and all mounting locations.

Models without factory threaded inserts in body panel:

- Partially thread an 8mm Hex Bolt into the threaded end of an 8mm Bolt and Nut Plate, **(Figure 2)**. Thread the Hex Bolt in until it is flush with the welded nut, **(Figure 3)**. Use the Hex Bolt as a handle and insert the Bolt and Nut Plate into the oval hole, **(Figure 4)**. Feed the bolt on the Bolt Plate through one of the hex shaped factory holes.
- Thread (1) 8mm Plastic Retainer onto the threaded end and down tight against the body panel, **(Figure 5)**. **NOTE:** The Plastic Retainer is designed to keep the Bolt/Nut Plate from falling into the body panel and to aid in Bracket installation.
- Repeat the previous Steps for the center and rear mounting locations as needed.
- Select the passenger/right HD Side Step. With assistance, hold the Side Step up against the body panel and very carefully slide the brackets over the Bolt Plates, **(Figure 6)**. Attach each

**HD WHEEL TO WHEEL SIDE STEP
2010-17 25-3500 DODGE RAM CREW CAB 8ft BED**

bracket to each Bolt Plate with (1) 8mm Flat Washer, (1) 8mm Lock Washer and (1) 8mm Hex Nut, **(Figure 6)**. Do not tighten at this time. Repeat as required.

- e. With the Side Step secure, starting at the front, remove the 8mm Hex Bolt from the nut on the Bolt Plate. Rotate the Bolt on the Bolt Plate until the threaded nut lines up with the remaining hole in the Mounting Bracket and body panel, **(Figures 6—8)**. Attach the Bracket to the Nut with (1) 8mm x 30mm Hex Bolt, (1) 8mm Lock Washer and (1) 8mm Flat Washer, **(Figures 7 & 8)**. Do not fully tighten hardware at this time.
- f. Repeat above Steps for all mounting locations requiring Bolt Plates, (no threaded inserts).

All mounting locations with factory threaded inserts:

- a. Attach each bracket directly to the threaded inserts with (2) 8mm x 30mm Hex Bolts, (2) 8mm Lock Washers and (2) 8mm Flat Washer, **(Figures 9 & 10)**.
 - b. Repeat above Step as required and snug but do not fully tighten hardware at this time.
3. Next, select the passenger side front Support Bracket, **(Figures 11 & 12)** **NOTE:** Passenger side Front Support Bracket is the same as driver side Center and Rear Support Brackets. Attach the Bracket to the front facing side of the front Bracket with (1) 8mm x 30mm Hex Bolt, (2) 8mm Flat Washers and (1) 8mm Nylon Lock Nut, **(Figures 11 & 12)**.
 4. Rotate the Support Bracket to the back of the pinch weld. Line up the slots in the top of the Support Bracket with the (2) factory holes in the pinch weld. Attach the Bracket to the back of the pinch weld with (2) 6mm x 25mm Hex Bolts, (4) 6mm Flat Washers and (2) 6mm Nylon Lock Nuts, **(Figures 13 & 14)**. Do not fully tighten hardware at this time. **IMPORTANT:** 2009-10 models are not equipped with factory holes and will require drilling through the pinch weld to attach the Support Bracket. Do not drill through pinch weld at this time, **(see Step 7)**.
 5. Move along the side of the body panel to the center mounting location, **(Figure 15)**. Select the passenger side center Support Bracket. Repeat **Steps 3 & 4** to install the passenger side center Support Bracket to the **back** of the center mounting arm. **NOTE:** Passenger side center and rear Support Brackets are the same as the driver side front Support Bracket.
 6. Move to the rear bracket. Repeat **Step 5** to attach (1) passenger side center/rear Support Bracket to the back of the rear mounting arm, **(Figure 16)**.
 7. Properly level and adjust the HD Side Step and fully tighten all hardware.

Drilling instructions for all Support Brackets on 2009-10 models:

- a. Make sure the HD Side Step is level to the vehicle. Adjust and tighten all mounting hardware.
 - b. Line up the slots on the Support Brackets with the back of the pinch weld. Mark the location of the slots onto the pinch weld, **(Figure 12)**.
 - c. Drill (2) 1/4" holes through the pinch weld for each Support Bracket. **IMPORTANT:** Do not drill too close to the bottom edge of the pinch weld. Adjust the Brackets as necessary to move the slots up the body panel away from the edge. Drill the holes toward the outside of the slots.
 - d. Attach each Support Bracket to the pinch weld with (2) 6mm Hex Bolts, (4) 6mm Flat Washers and (2) 6mm Nylon Lock Nuts, **(Figures 13—16)**.
 - e. Check for level then tighten all hardware.
8. Move to the driver side of the vehicle. Repeat **Steps 1—7** for driver side installation.
 9. Do periodic inspections to the installation to make sure that all hardware is secure and tight.

To protect your investment, wax this product after installing. Regular waxing is recommended to add a protective layer over the finish. Do not use any type of polish or wax that may contain abrasives that could damage the finish. Mild soap may be used to clean the HD Side Steps.

Passenger Side Installation Pictured

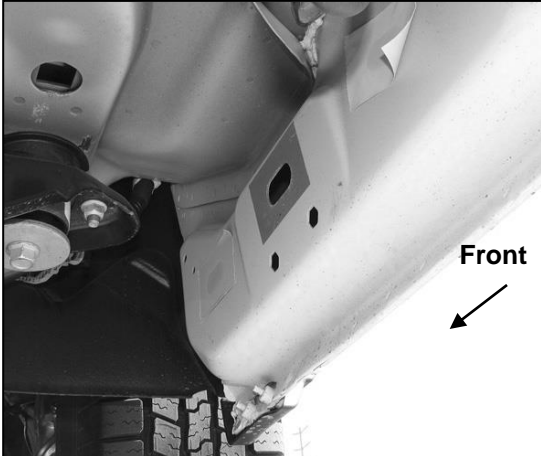

(Fig 1) Passenger/right front mounting location (model without threaded inserts)

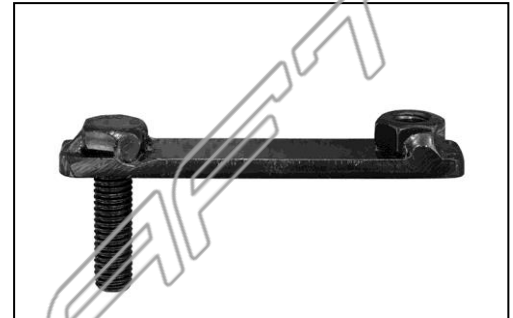

(Fig 2) 8mm Bolt-8mm Nut Plate, NOTE: 8mm Bolt-Nut Plate is not required on models with factory threaded inserts

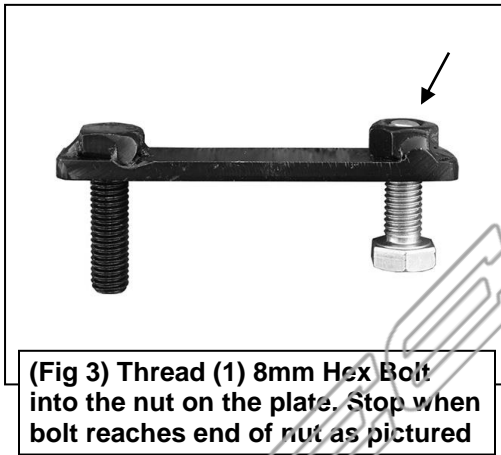

(Fig 3) Thread (1) 8mm Hex Bolt into the nut on the plate. Stop when bolt reaches end of nut as pictured

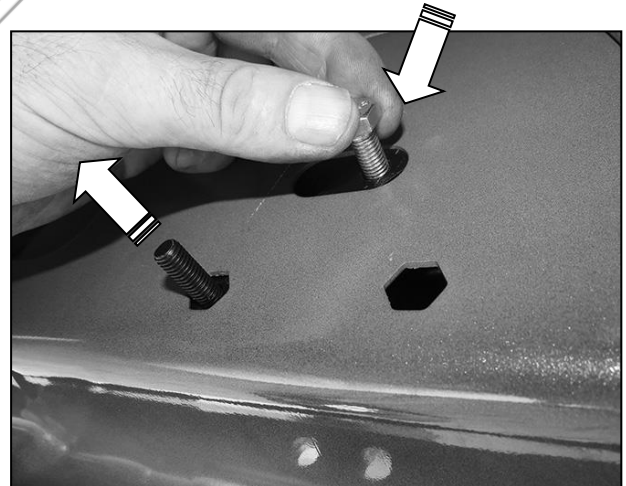

(Fig 4) Use the loose Hex Bolt as a handle. Insert the Bolt Plate into the oval hole and feed the threaded end out either factory hex shaped hole. IMPORTANT: Do not let go of the hex bolt until after Plastic Retainer has been threaded onto bolt (Fig 6)

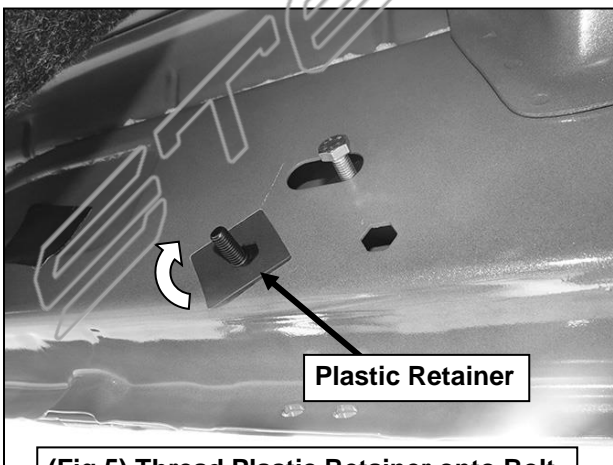

(Fig 5) Thread Plastic Retainer onto Bolt Plate to hold Bolt Plate in position.

**HD WHEEL TO WHEEL SIDE STEP
2010-17 25-3500 DODGE RAM CREW CAB 8ft BED
Passenger Side Installation Pictured**

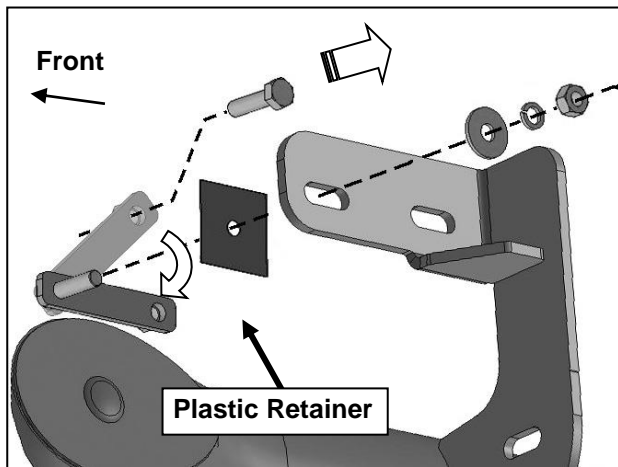

8mm Flat Washer
8mm Lock Washer
8mm Hex Nut

Remove Hex Bolt, rotate Bolt/Nut Plate to line up threaded nut with body panel and Mounting Bracket (see Fig 6)

8mm Hex Bolt
8mm Lock Washer
8mm Flat Washer

(Fig 6) Attach Bracket to Bolt Plate

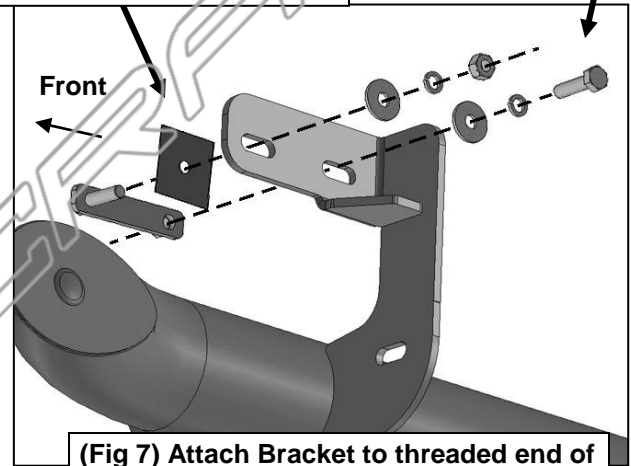

(Fig 7) Attach Bracket to threaded end of Bolt Plate first. Remove 8mm Hex Bolt (see Fig 3). Rotate Bolt Plate to line up with remaining factory hex shaped hole.

8mm Hex Bolt
8mm Lock Washer
8mm Flat Washer

8mm Flat Washer
8mm Lock Washer
8mm Hex Nut

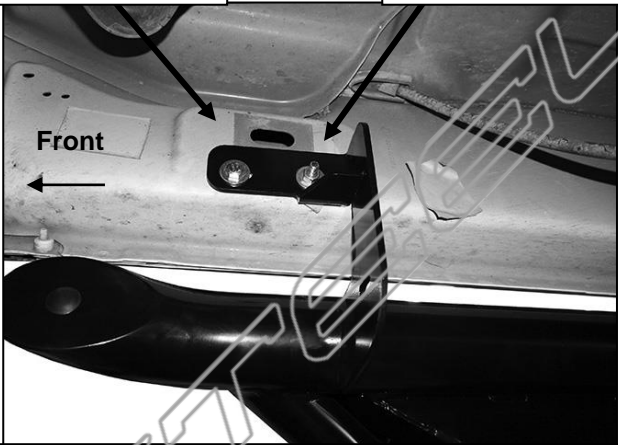

(Fig 8) Passenger/right front 2009-2010 model pictured. IMPORTANT: All models without holes in pinch weld will require drilling 1/4" holes through pinch weld to attach support brackets. Do complete installation of sidebars first, level sidebar before drilling holes for support bracket.

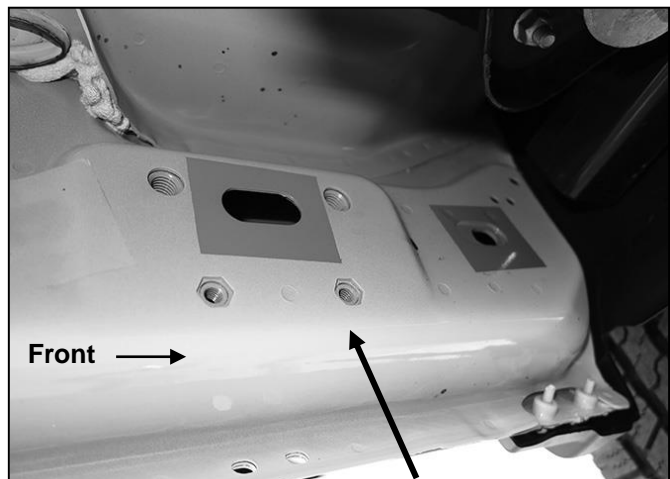

(Fig 9) Driver side front mid 2015-on, an example of models with factory installed threaded inserts

HD WHEEL TO WHEEL SIDE STEP
2010-17 25-3500 DODGE RAM CREW CAB 8ft BED

Passenger Side Installation Pictured

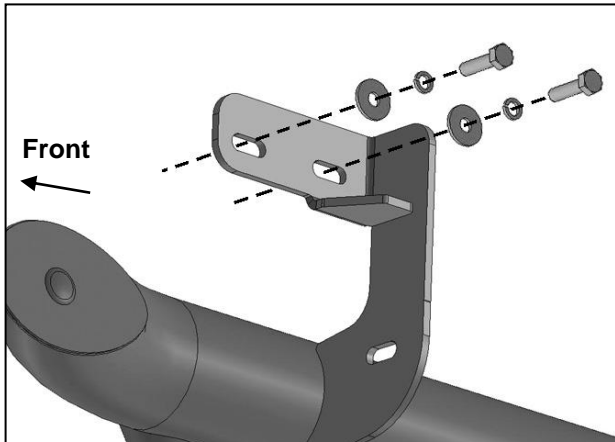

(Fig 10) Passenger side front on models with factory installed threaded inserts. Bolt Plate not required

- (2) 8mm Hex Bolts
- (2) 8mm Lock Washers
- (2) 8mm Flat Washers

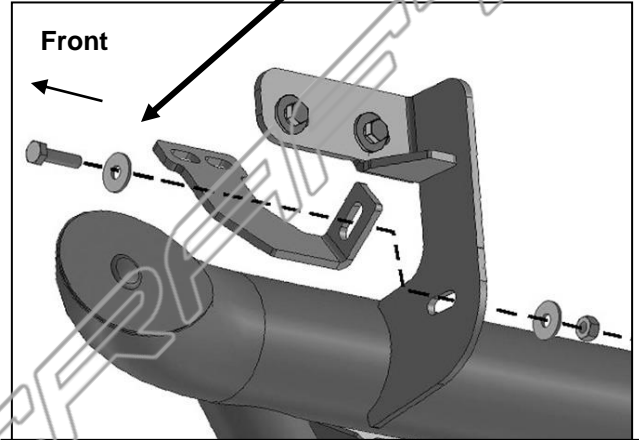

(Fig 11) Attach passenger/right front Support Bracket to front facing side of Mounting Bracket

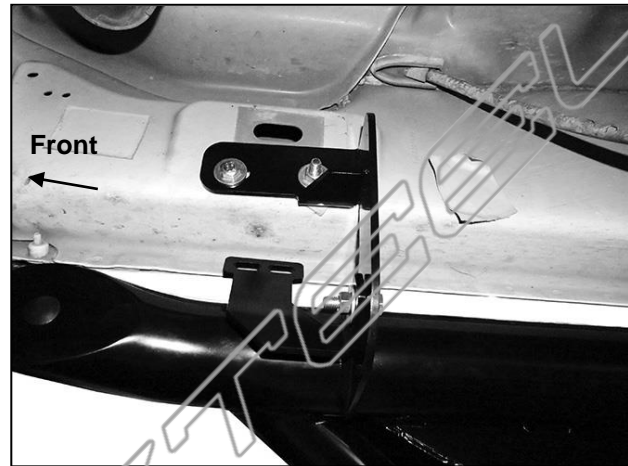

(Fig 12) 2009-10 passenger/right front pictured

- (2) 6mm Hex Bolts
- (4) 6mm Flat Washers
- (2) 6mm Nylon Lock Nuts

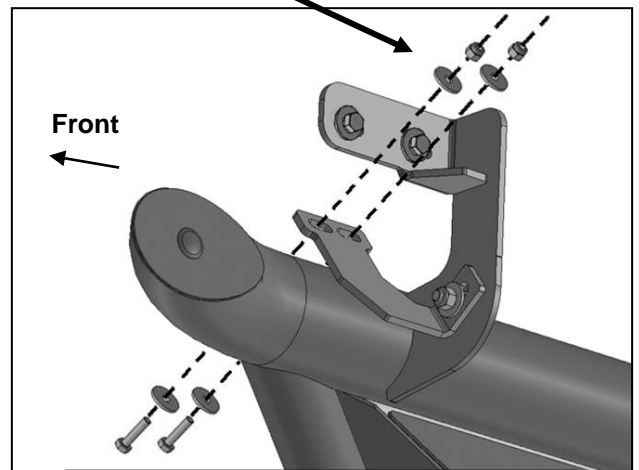

(Fig 13) Attach Support Bracket to back of pinch weld (2011-on models with factory holes in pinch weld only)

IMPORTANT: 2009-2010 models without holes in pinch weld will require drilling 1/4" holes through pinch weld to attach driver side front support bracket. Do complete installation of sidebars first, level sidebar before drilling holes for support bracket.

HD WHEEL TO WHEEL SIDE STEP
2010-17 25-3500 DODGE RAM CREW CAB 8ft BED
Passenger Side Installation Pictured

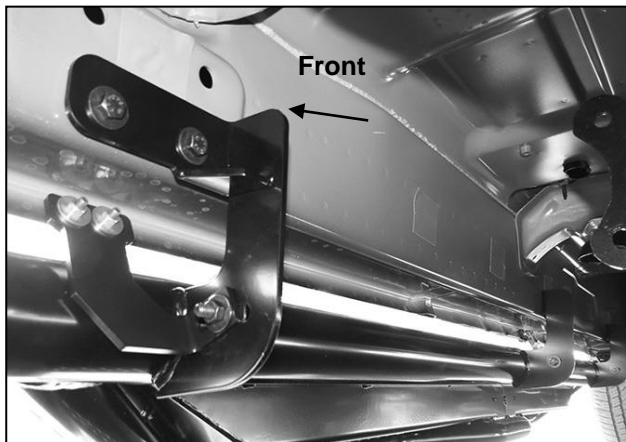

(Fig 14) Passenger/right front complete installation

IMPORTANT: 2009-2010 models without holes in pinch weld will require drilling 1/4" holes through pinch weld to attach driver side front support bracket. Do complete installation of sidebars first, level sidebar before drilling holes for support bracket.

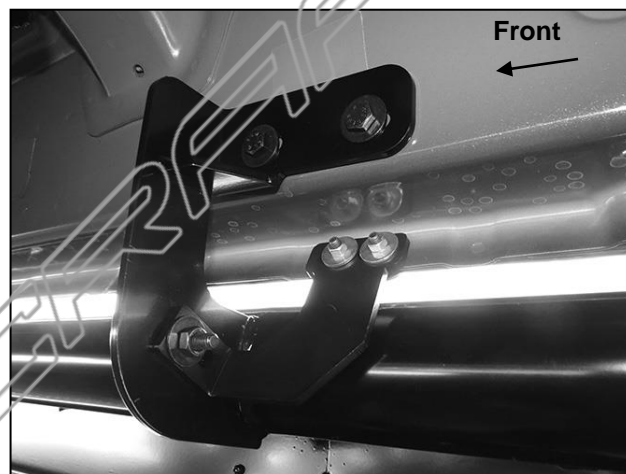

(Fig 15) Passenger/right center complete installation. NOTE: Center and rear Support Brackets attach to back of mounting bracket on HD Side Step

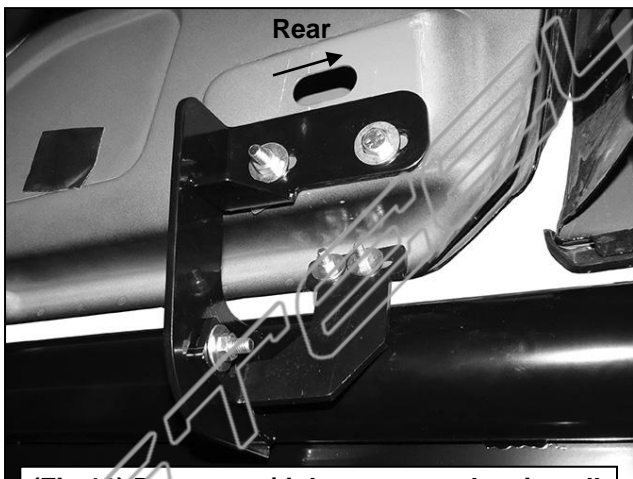

(Fig 16) Passenger/right rear complete install



Complete Installation