

HEAVY DUTY REPLACEMENT WINCH FRONT BUMPER 2017-21 FORD SUPER DUTY

PARTS LIST:

1	Heavy Duty Replacement Winch Front Bumper	8	12mm x 40mm Bolt Plates
1	Driver/left Frame Bracket	20	12-1.75mm x 50mm Hex Bolts
1	Passenger/right Frame Bracket	48	12mm x 32mm x 3mm Flat Washers
1	Winch Tray	28	12mm Lock Washers
1	Winch Access Cover	28	12-1.75mm Hex Nuts
1	Driver/left Light Mount (OEM LED)	2	8-1.25mm x 20mm Hex Bolts
1	Passenger/right Light Mount (OEM LED)	4	8mm x 24mm x 2mm Flat Washers
1	Driver/left Fog Light Block Off	2	8mm Nylon Lock Nuts
1	Passenger/right Fog Light Block Off	5	6mm Combo Button Head Bolts
1	Driver/left Upper U-Bracket (OEM STD light)	6	6mm x 25mm Button Head Bolts
1	Passenger/right Upper U-Brkt (OEM STD light)	4	6mm x 16mm Hex Bolts
2	Lower U-Brackets (OEM fog light only)	13	6mm x 18mm x 1.6mm Flat Washers
1	Adaptive Cruise Control Plastic Cover	10	6mm Lock Washers
1	ACC Adapter Plate	10	6mm Hex Nuts
2	Sensor "L" Mounting Brackets	1	4mm Wrench
2	Plastic Plugs for license plate mount	1	2.5mm Wrench

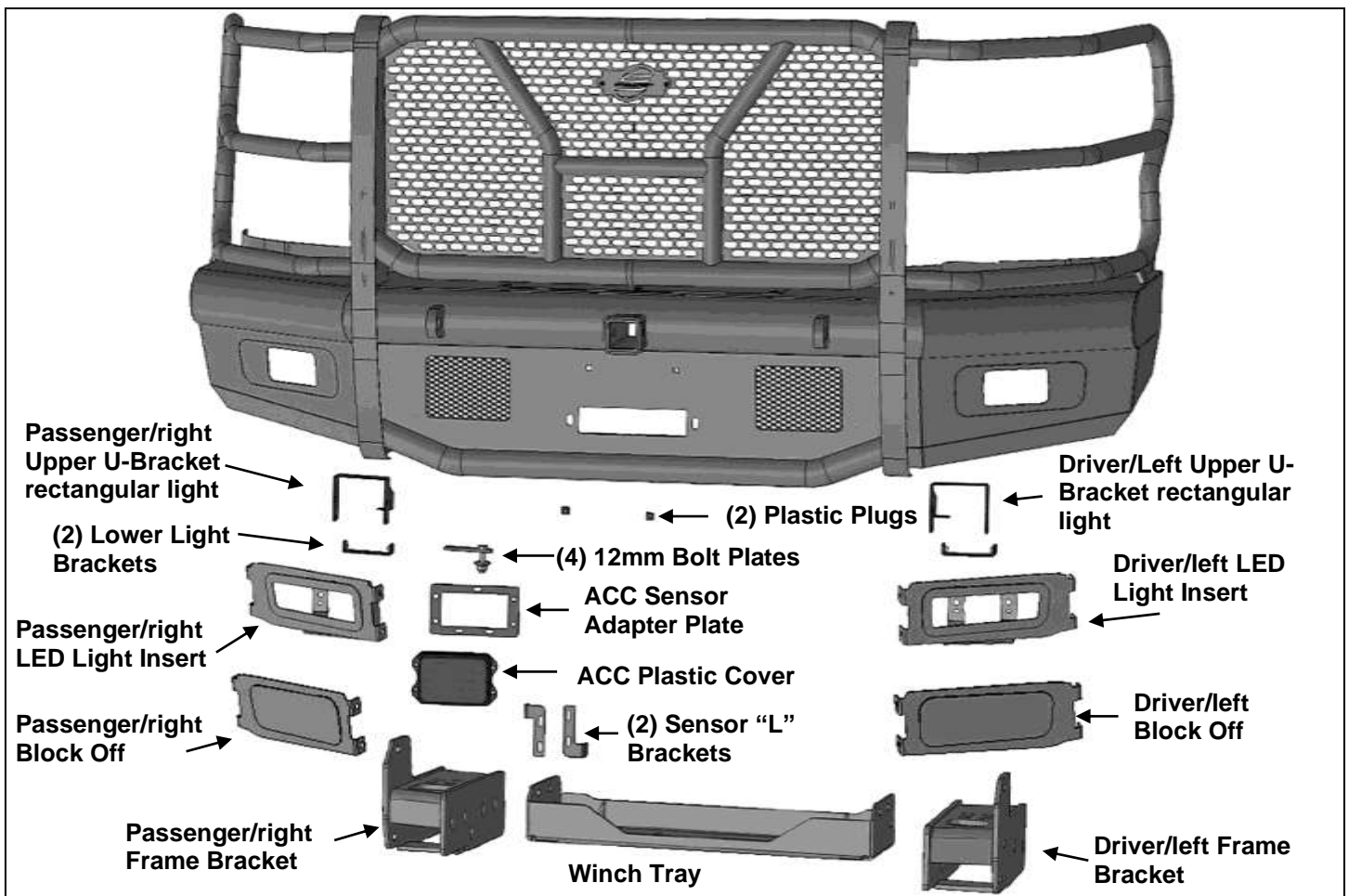

PROCEDURE:

REMOVE CONTENTS FROM BOX. VERIFY ALL PARTS ARE PRESENT. READ INSTRUCTIONS CAREFULLY BEFORE STARTING INSTALLATION. BUMPER IS HEAVY, ASSISTANCE IS HIGHLY RECOMMENDED TO AVOID POSSIBLE INJURY OR DAMAGE TO THE VEHICLE.

HEAVY DUTY REPLACEMENT WINCH FRONT BUMPER 2017-21 FORD SUPER DUTY

1. Remove the license plate and bracket. On models with factory fog lights and/or adaptive cruise control sensor, unplug and move any wiring harness leading to the front bumper, **(Figures 1 & 2)**.
2. Remove the outer bumper supports attaching the ends of the bumper to the outside of the frame, **(Figure 3)**. Remove the plastic covers from the tow hooks to uncover the bumper bolts, **(Figure 4)**.
3. Place blocks or jack stands under the front bumper to support it during mounting bolt removal. Once the bumper has been safely supported, remove the (8) factory bumper bolts, **(Figure 5)**.
WARNING! Assistance is required to hold the bumper in place during bolt removal to prevent the bumper from falling. Carefully slide the bumper off over the tow hooks.
4. Remove the tow hooks from the end of the frame, **(Figure 6)**. Next, remove the factory hex nuts, lower frame extension and double bolt plates from the bottom of the frame, **(Figures 2 & 6)**.
5. Select the driver/left Frame Bracket, **(Figure 7)**. Slide the Bracket over the end of the frame. Line up the slots in the sides of the Bracket with the holes in the frame. Select (4) 12mm Bolt Plates. Insert the Bolt Plates into the open end of the frame and out through the Bracket. Attach the Bracket to the Bolt Plates with (4) 12mm Flat Washers, (4) 12mm Lock Washers and (4) 12mm Hex Nuts, **(Figure 7)**. Leave hardware loose at this time.
6. Attach the top of the Bracket to the frame with the included (4) 12mm x 50mm Hex Bolts, (8) 12mm Flat Washers, (4) 12mm Lock Washers and (4) 12mm Hex Nuts, **(Figure 8)**. Leave hardware loose.
7. Repeat **Steps 5 & 6** to install the passenger/right Frame Bracket.
8. Next, select the Winch Tray Assembly, **(Figure 9)**. Slide the Winch Tray between the two Brackets. Attach the Winch Tray to the Brackets with (6) 12mm x 50mm Hex Bolts, (12) 12mm Flat Washers, (6) 12mm Lock Washers and (6) 12mm Hex Nuts, **(Figure 9)**. Leave hardware loose at this time.
9. If installing winch, attach winch to Winch Tray at this time. Winch must be installed before Bumper is placed in position against Brackets. Also attach winch cable guide, (not included), to Bumper. Follow manufacturer's instructions to properly wire the winch to the electrical system.
10. Determine if the vehicle is equipped with an adaptive cruise control, (ACC), and note design of sensor.

Vehicles without ACC, skip to **Step 11**.

All Models with Adaptive Cruise Control.

- a. Remove the screen covering the square opening on the driver/left side of the Bumper, **(Figure 10)**. Select the (2) L/R "L" Brackets, **(Figures 10 & 11)**. **NOTE:** "L" Brackets are universal and fit either side of opening.
- b. Reuse the screen hardware to attach the "L" Brackets to the tabs on the back of the Bumper, **(Figure 11)**. Do not tighten hardware

Vehicles with "late" style ACC with tabs on top and bottom.

- a. Select the Mounting Bracket Adapter Plate, **(Figure 12)**.
- b. Attach the ACC sensor to the back of the Plate with the included (3) 6mm x 25mm Button Head Bolts, (6) 6mm Flat Washers, (3) 6mm Lock Washers and (3) 6mm Hex Nuts, **(Figure 12)**.
- c. Insert (3) 6mm x 25mm Button Head Bolts through the (3) holes in the ACC Plastic Cover, the ACC Brackets and out through the Plate. Secure with (3) 6mm Flat Washers, (3) 6mm Lock Washers and (3) 6mm Hex Nuts, **(Figure 13)**. Tighten all hardware.

Vehicles with early style ACC with mounting tabs on ends.

- a. Insert (3) 6mm x 25mm Button Head Bolts through the (3) holes in the ACC Plastic Cover, the Left and Right ACC Brackets and out through the adaptive cruise control. Secure with (3) 6mm Flat Washers, (3) 6mm Lock Washers and (3) 6mm Hex Nuts, **(Figure 14)**. Tighten all hardware.
11. With assistance, carefully position the Bumper Assembly up to the Brackets. Temporarily support the weight of the Bumper. **WARNING:** To avoid possible injury or damage to the vehicle, do not proceed until the bumper is fully and safely supported.
 12. Line up the (3) holes in the driver/left side of the Bumper with the (3) holes in the Frame Bracket. Attach the Bumper to the Bracket with the included (3) 12mm x 50mm Hex Bolts, (6) 12mm Flat Washers, (3) 12mm Lock Washers and (3) 12mm Hex Nuts, **(Figure 15)**. Do not fully tighten hardware at this time. Repeat to attach the passenger/right side of the Bumper to the Bracket.
 13. Level and adjust the Bumper and fully tighten all 12mm hardware to 65-70ft-lbs.
 14. Determine if vehicle is equipped with fog lights and the style of light.

Models with rectangular factory fog lights:

HEAVY DUTY REPLACEMENT WINCH FRONT BUMPER 2017-21 FORD SUPER DUTY

- a. Use a flat blade screwdriver to carefully pop out the tabs on the side of the fog light bracket attaching the light to the bracket, **(Figure 1)**. Pop the light out of the plastic bracket housing.
- b. Remove the adjustment screw and spring from the light assembly.
- c. Move to the driver/left fog light opening, **(Figure 16)**. Select the driver/left top U-Bracket, **(Figure 17)**. Attach the Bracket to the slot in the light opening with the included (1) 8mm x 20mm Hex Bolt, (2) 8mm x 24mm STD Flat Washers and (1) 8mm Nylon Lock Nut, **(Figure 17)**.
- d. Spread the sides of the Bracket enough to slide the OE plastic fog light between and into the Bracket, **(Figure 18)**. Select (1) Lower U-Bracket. Attach the Lower Bracket to the Upper Bracket with (2) 6mm x 16mm Hex Bolts, (2) 6mm Lock Washers and (2) 6mm Flat Washers, **(Figure 19)**.
- e. Insert the factory spring between the tab on the Bracket and the light. Insert the screw through the tab, spring and into the fog light, **(Figure 19)**.
- f. Repeat to install the passenger/right fog light.

Models with optional narrow factory LED Fog Light (2020-on models)

- a. Remove the light mount from the bumper, **(Figure 20)**. Remove the screws attaching the light to the plastic mount, **(Figure 21)**.
- b. Remove the driver/left rectangular fog light mount from the back of the Bumper, **(Figure 22)**.
- c. Select the driver/left LED light mount insert. Reuse the hardware to attach the Mount to the tabs on the back of the Bumper, **(Figure 23)**.
- d. Reuse the factory screws to attach the LED fog light to the LED light mount, **(Figure 23)**.
- e. Repeat previous Steps to install the passenger/right LED Light Mount and light.

Models without fog lights.

- a. Remove the preinstalled driver/left rectangular fog light mount insert from the back of the HD Bumper, **(Figure 23)**.
 - b. Select the driver/left Block Off. Reuse the hardware to attach the Block Off to the tabs on the back of the Bumper, **(Figure 23)**.
 - c. Repeat previous Steps to install the passenger/right Block Off.
15. Use the included (2) Plastic Plugs to attach the license plate, (if required), to the Bumper, **(Figure 24)**.
16. On models with grille mounted factory camera, remove the center screen, **(Figure 24)**.
17. Reattach the factory wiring harness. Adjust lights as necessary and tighten all hardware.
18. Do periodic inspections to the installation to make sure that all hardware is secure and tight.

To protect your investment, Do not use any type of polish or wax that may contain abrasives that could damage the finish. Mild soap may be used to clean the HD Front Bumper assembly.

Driver/left Side Installation Pictured



(Fig 1) On models with fog lights, unplug wire harness from back of light

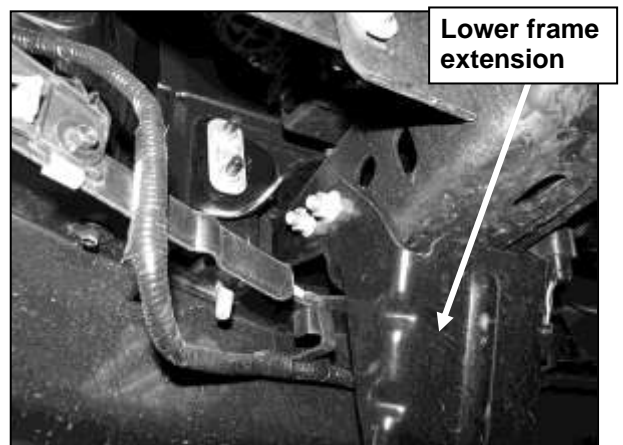

(Fig 2) Release clips attaching the wire harness for fog lights if equipped (driver side)

**HEAVY DUTY REPLACEMENT WINCH FRONT BUMPER
2017-21 FORD SUPER DUTY**

Driver/left Side Installation Pictured

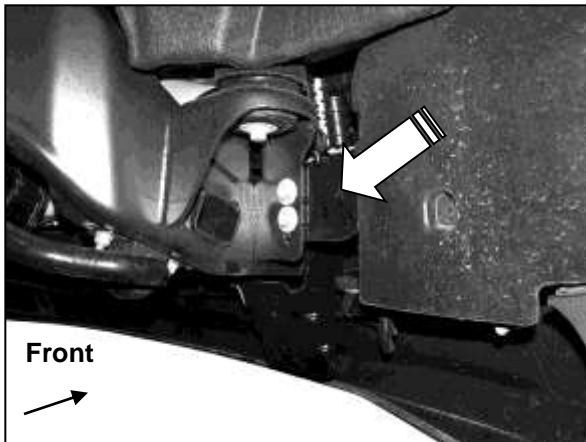

(Fig 3) Remove outer bumper support brackets between frame and bumper (arrow)

WARNING! Do not crawl under bumper unless it is properly supported on blocks or stands or the bumper may fall.

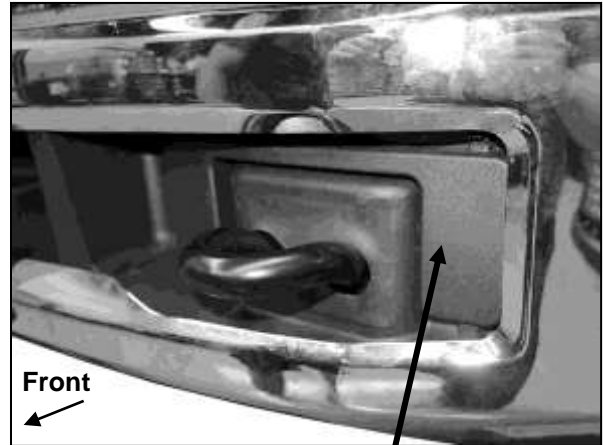

(Fig 4) Remove plastic cover around tow hook



(Fig 5) Remove bumper bolts (driver side pictured)

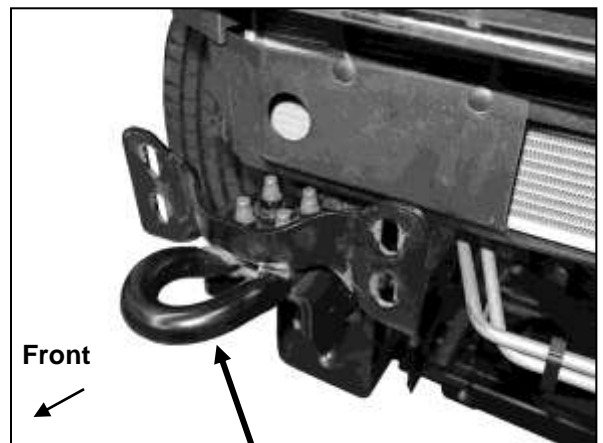

(Fig 6) Remove tow hook assembly and lower frame extension (not pictured-see Fig 2)

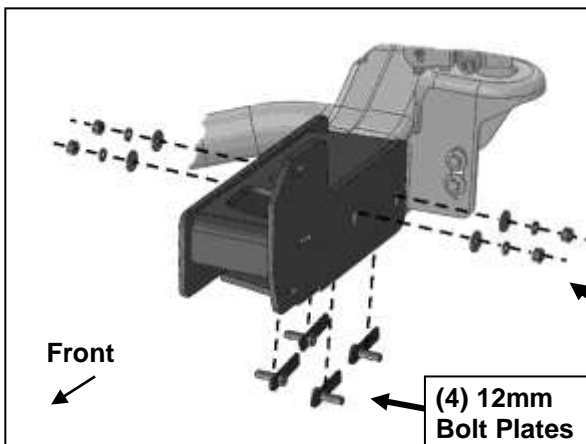

(Fig 7) Insert Bolt Plates into open end of frame. Attach Bracket to sides of frame

- (4) 12mm Flat Washers
- (4) 12mm Lock Washers
- (4) 12mm Hex Nuts

(4) 12mm Bolt Plates

**HEAVY DUTY REPLACEMENT WINCH FRONT BUMPER
2017-21 FORD SUPER DUTY**

Driver/left Side Installation Pictured

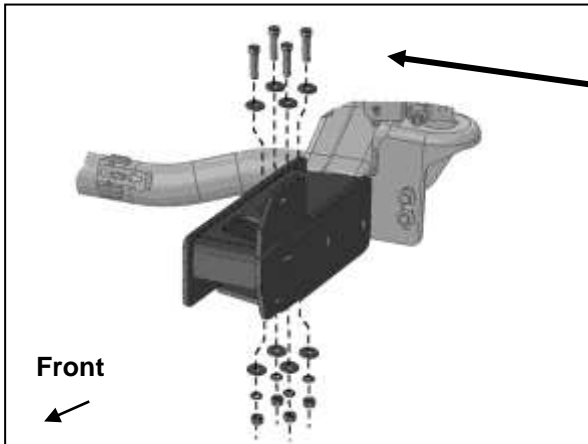

(Fig 8) Attach top of Bracket to (4) top mounting holes in frame

- (4) 12mm x 50mm Hex Bolts
- (8) 12mm Flat Washers
- (4) 12mm Lock Washers
- (4) 12mm Hex Nuts

- (3) 12mm x 50mm Hex Bolts
- (6) 12mm Flat Washers
- (3) 12mm Lock Washers
- (3) 12mm Hex Nuts

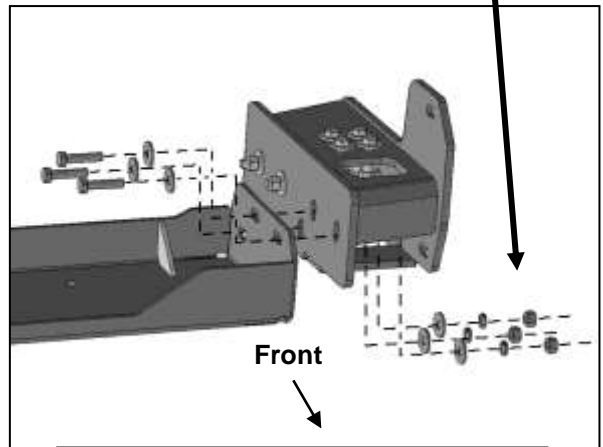

(Fig 9) Attach Winch Tray to Bracket

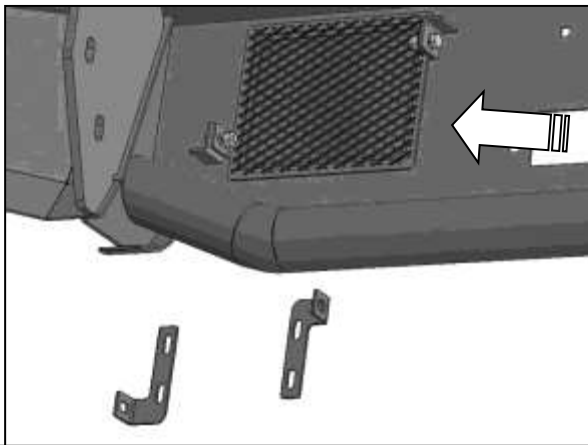

(Fig 10) Remove screen (arrow). Select "L" Brackets

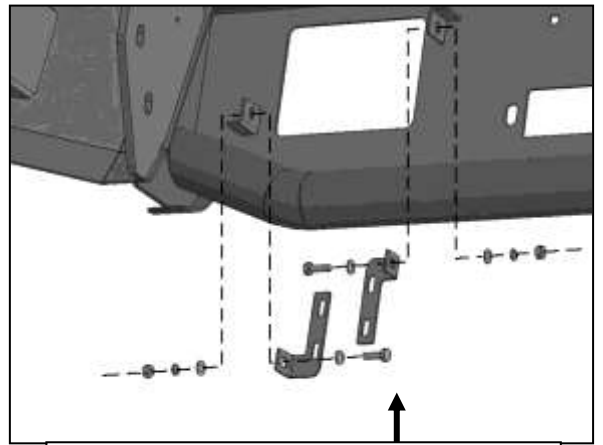

(Fig 11) Reuse hardware to attach "L" Brackets to tabs on back of Bumper

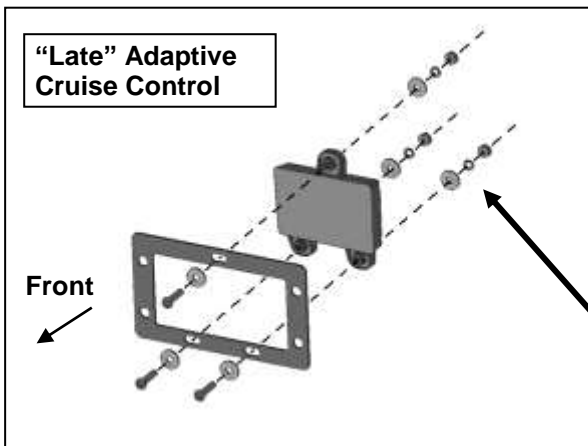

(Fig 12) Attach "Late" ACC sensor to back of Adapter Bracket

- (3) 6mm Button Head Bolts
- (3) 6mm Flat Washers
- (3) 6mm Lock Washers
- (3) 6mm Hex Nuts

HEAVY DUTY REPLACEMENT WINCH FRONT BUMPER
2017-21 FORD SUPER DUTY

Driver/left Side Installation Pictured

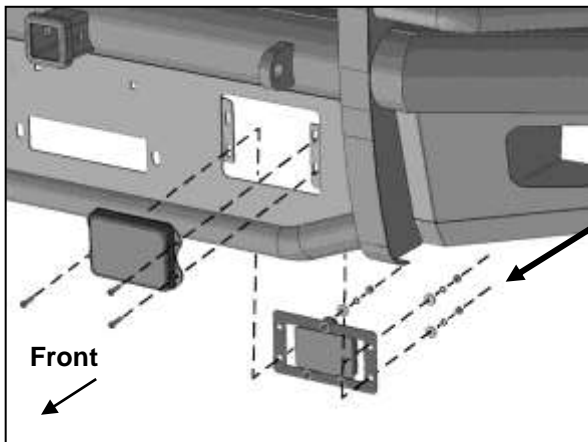

(Fig 13) Attach Adapter Bracket with "Late" ACC and plastic cover to the ACC Brackets

- (3) 6mm x 25mm Button Head Bolts
- (3) 6mm Flat Washers
- (3) 6mm Lock Washers
- (3) 6mm Hex Nuts

ACC Plastic Cover

"Early" Adaptive cruise control

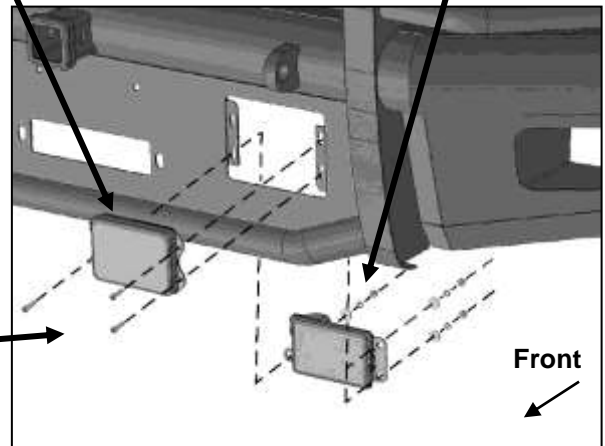

(Fig 14) Attach "Early" ACC and plastic cover to the ACC Brackets

- (3) 6mm x 25mm Button Head Bolts
- (3) 6mm Flat Washers
- (3) 6mm Lock Washers
- (3) 6mm Hex Nuts

- (3) 12mm x 50mm Hex Bolts
- (6) 12mm Flat Washers
- (3) 12mm Lock Washers
- (3) 12mm Hex Nuts

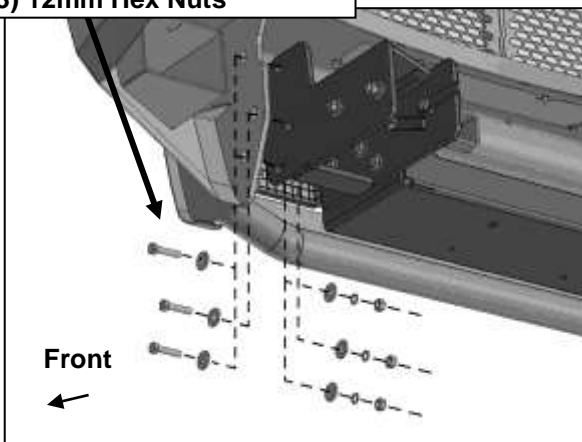

(Fig 15) Attach Bumper to side of Bracket

WARNING! Do not crawl under bumper unless it is properly supported on blocks or stands or the bumper may fall.

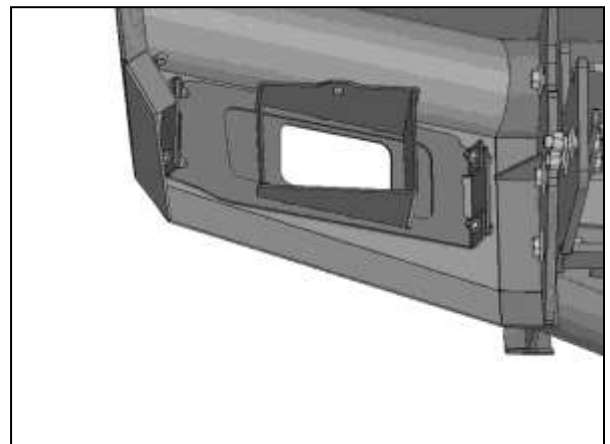

(Fig 16) Optional OEM fog light installation (light not included). Attach driver/left Upper Bracket to the slot in top of the opening

**HEAVY DUTY REPLACEMENT WINCH FRONT BUMPER
2017-21 FORD SUPER DUTY**

Driver/left Side Installation Pictured

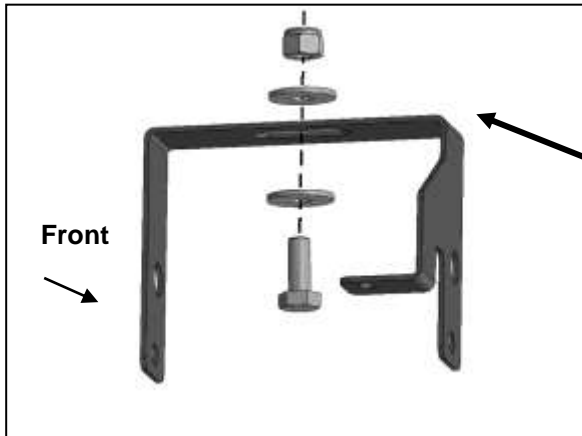

WARNING! Do not crawl under bumper unless it is properly supported on blocks or stands or the bumper may fall.

8mm x 20mm Hex Bolt
(2) 8mm Flat Washers
8mm Nylon Lock Nut

(Fig 17) Optional OEM fog light installation (light not included). Attach driver/left Upper Bracket to the slot in top of the opening



(Fig 18) Carefully spread sides to slide OEM fog light into position in pivot holes

6mm x 16mm Hex Bolt
6mm Lock Washer
6mm Flat Washer

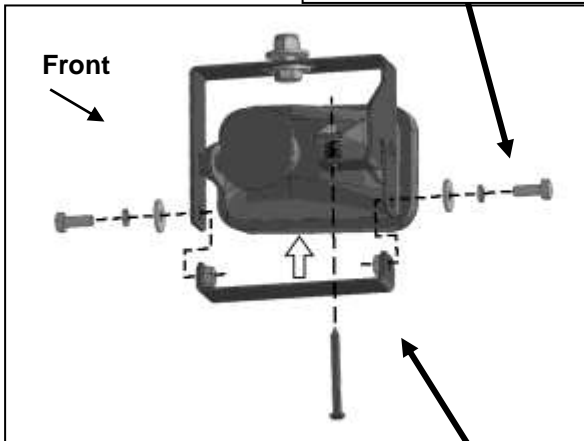

(Fig 19) Attach lower U Bracket to Upper Bracket. Reuse factory adjustment hardware (screw, spring and plastic nut)



(Fig 20) Models equipped with LED fog light option, remove fog light assembly from factory bumper

**HEAVY DUTY REPLACEMENT WINCH FRONT BUMPER
2017-21 FORD SUPER DUTY**

Driver/left Side Installation Pictured



(Fig 21) Remove screws to remove narrow LED fog light from plastic mount

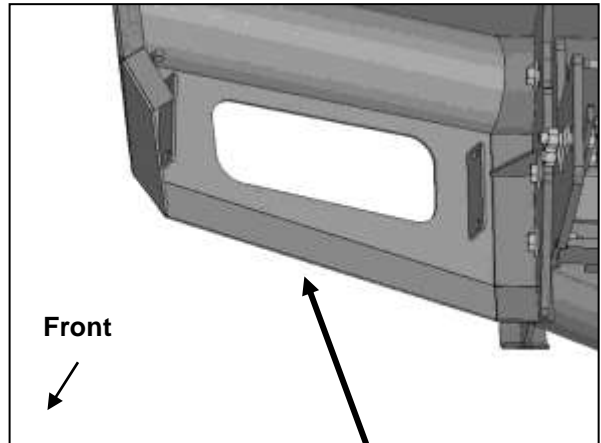

(Fig 22) Remove fog light mount from back of Bumper (driver/left side illustrated)

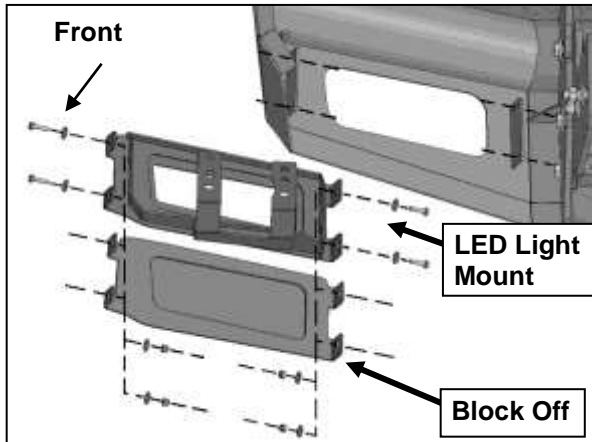

(Fig 23) Models with LED fog lights only, reuse screws to attach LED fog light to Light Mount. Reuse mounting hardware to attach LED Fog Light assembly or Block Offs to tabs on back of Bumper

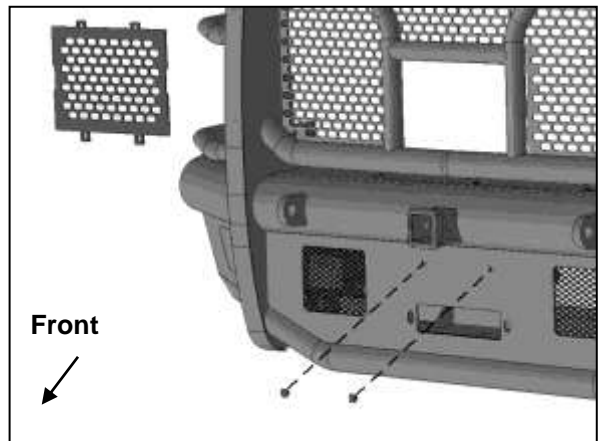

(Fig 24) Push Plastic Plugs into holes in Bumper for license plate. Remove center screen if equipped with grille mounted camera