

PARTS LIST:

1	Front Roof Platform	7	Long Bracket Foam Spacers
1	Rear Roof Platform	36	8mm x 25mm Button Head Bolts
4	Front/Rear Mounting Brackets	4	8mm x 16mm Hex Bolts
3	Center Connector Brackets	68	8mm x 22mm OD x 2mm Flat Washers
7	Clamping Brackets	40	8mm Lock Washers
2	Driver/Left Light Brackets	28	8mm hex Nuts
2	Passenger/Right Light Brackets	8	8mm Nut Plates
1	Driver/Left Foam Seam	28	6mm x 20mm Button Head Bolts
1	Center Foam Seam	8	6mm x 20mm T-Bolts
1	Passenger/Right Foam Seam	64	6mm x 12mm OD x 1.6mm Flat Washers
5	6mm Thick Foam Spacers	36	6mm Lock Washers
2	2mm Thick Foam Spacers	36	6mm Hex Nuts
8	Front/Rear Top Foam Spacers	1	5mm Hex Wrench
6	Center Top Foam Spacers	1	4mm Hex Wrench

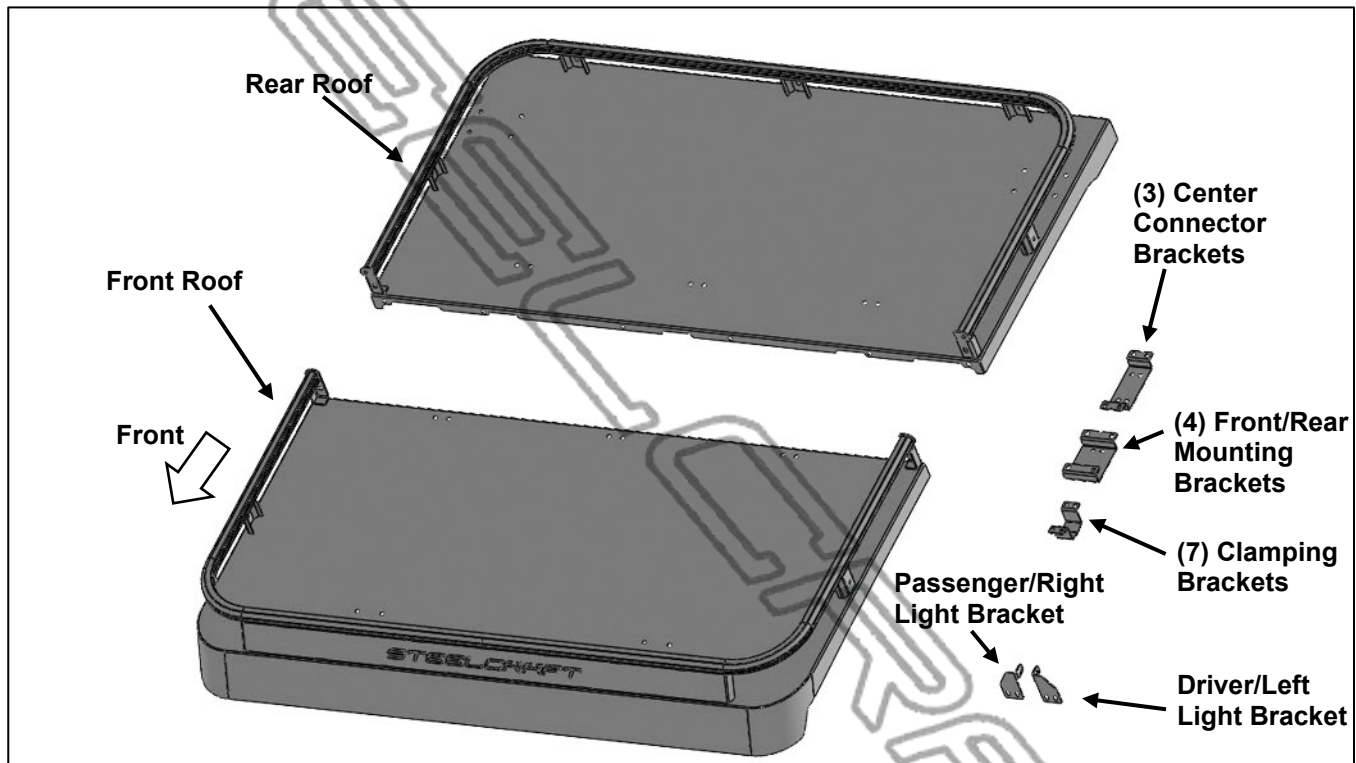

PROCEDURE:

1. REMOVE CONTENTS FROM BOX. VERIFY ALL PARTS ARE PRESENT. READ INSTRUCTIONS CAREFULLY. USE ILLUSTRATION TO IDENTIFY BRACKETS. REMOVE PREVIOUSLY INSTALLED ROOVES AND RACKS.
2. Starting above the roof of the vehicle, locate and remove the bolts securing the roof to the frame, **(Figure 1)**. Remove the clamps from the frame underneath the roof, **(Figure 2)**.
3. Select the Brackets and Foam Spacers. Follow **Figures 3—5** to attach the Spacers to the correct Brackets. Do not tighten hardware.
4. Following the mounting locations in **Figure 7** attach the (4) Mounting and (3) Clamping Brackets to the frame with (4) 6mm Button Head Bolts, (8) 6mm Flat Washers, (4) 6mm Lock Washers and (4) 6mm hex Nuts for each Bracket assembly, **(Figures 6 & 7)**. Do not tighten hardware.
5. **For Lightbar installation, (lightbar not included):**
  - a. Insert (4) T-Bolts into the channel in the rails, **(Figure 8)**. Slide the T-Bolts to the desired location,
  - b. Select the Driver/Left Light Bracket. Attach the Bracket to (2) T-Bolts with (2) 6mm Flat Washers, (2) 6mm Lock Washers and (2) 6mm Hex Nuts, **(Figure 9)**. Do not tighten hardware.
  - c. Repeat the previous **Step** to attach the Passenger/Right Light Bracket.

## ROOF PLATFORMS 2015-24 KAWASAKI MULE PRO

- d. Attach desired lightbar to the Light Brackets with (2) 8mm x 16mm Hex Bolts, (2) 8mm Lock washers and (2) 8mm Flat Washers, **(Figure 10)**. Do not tighten hardware.
- e. Level, adjust and center the lightbar. Then tighten all lightbar hardware.
6. Select the (3) Foam Seams. Attach the Seams to the Front Roof Platform, **(Figure 11)**.
7. Attach the Front and Rear Roof Platforms with (6) 8mm Button Head Bolts, (12) 8mm Flat Washers, (6) 8mm Lock Washers and (6) 8mm Hex Nuts, **(Figure 12)**. Secure the rails above the Roof Platforms with (2) 8mm Button Head Bolts, (4) 8mm Flat Washers, (2) 8mm Lock Washers and (2) 8mm Hex Nuts, **(Figure 13)**. Do not tighten hardware.
8. With assistance, lift the Platform assembly onto the Mounting Brackets. Attach the Platform to the mounting tab that points inward on the (4) Front/Rear Mounting Brackets with (8) 8mm Button Head Bolts, (8) 8mm Lock Washers, (8) 8mm Flat Washers, and (8) 8mm Nut Plates, **(Figure 14)**. Do not tighten Hardware.
9. Attach the rest of the mounting tabs on all Brackets to the Roof Platforms with (20) 8mm Button Head Bolts, (40) 8mm Flat Washers, (20) 8mm Lock Washers and (2) 8mm Hex Nuts, **(Figures 14—18)**. Do not tighten hardware.
10. Level and adjust the Roof Platforms, then tighten all hardware.
11. Do periodic inspections to the installation to make sure that all hardware is secure and tight.

**To protect your investment**, Do not use any type of polish or wax that may contain abrasives that could damage the finish. Mild soap may be used to clean the Platform.

### Driver Side Installation Pictured

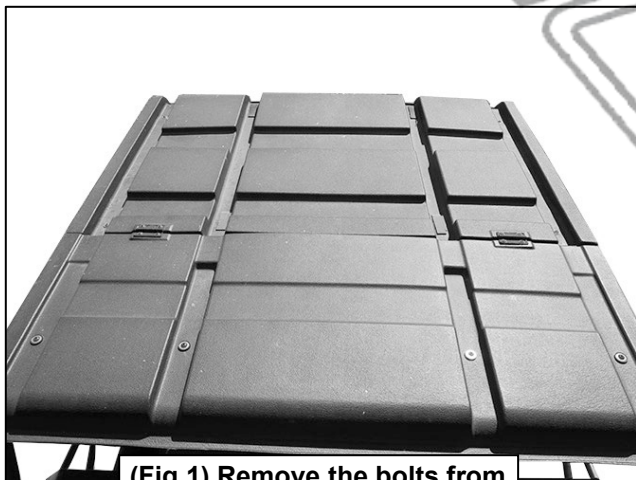

**(Fig 1) Remove the bolts from the top of the factory roof**

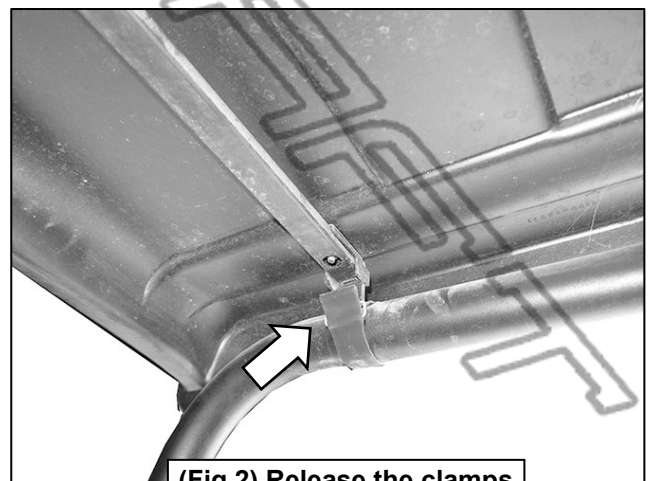

**(Fig 2) Release the clamps from underneath the roof**

Driver Side Installation Pictured

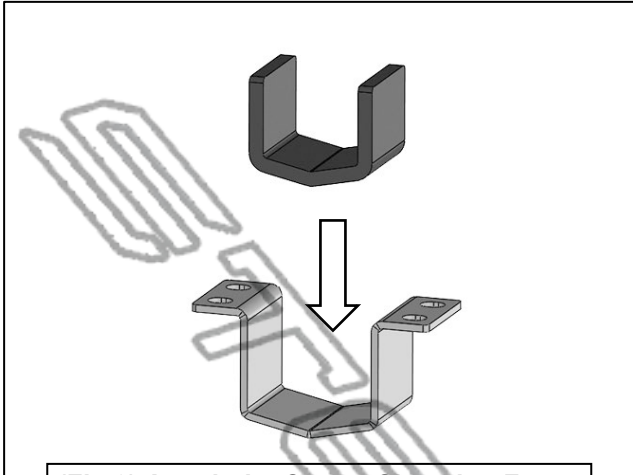

(Fig 3) Attach the Center Clamping Foam Spacers to the Center Clamping Bracket

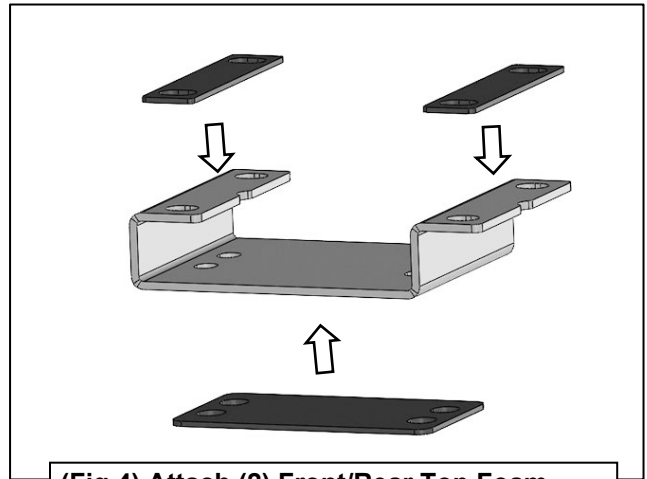

(Fig 4) Attach (2) Front/Rear Top Foam Spacers to the top of the Mounting Bracket and (1) Long Foam Spacer to the bottom

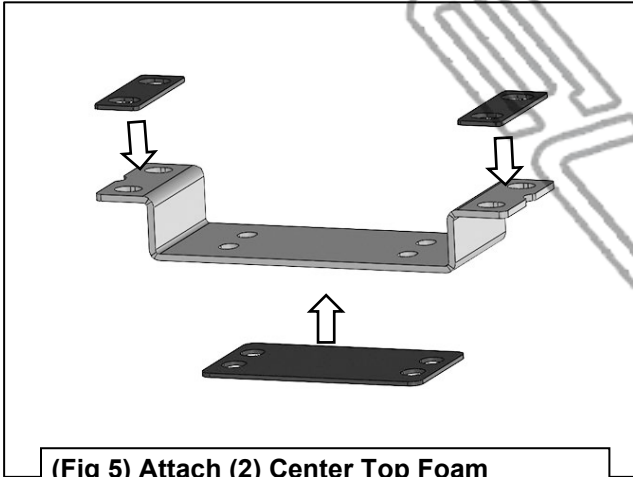

(Fig 5) Attach (2) Center Top Foam Spacers to the top of the Mounting Bracket and (1) Long Foam Spacer to the bottom

- (4) 6mm Button Head Bolts
- (8) 6mm Flat Washers
- (4) 6mm Lock Washers
- (4) 6mm Hex Nuts

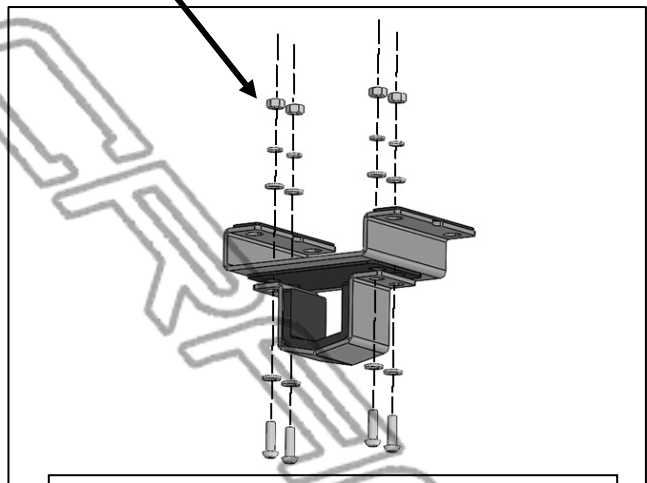

(Fig 6) Attach (1) Clamping Bracket and (1) Front/Rear Mounting Bracket to the frame



(Fig 7) All Mounting Brackets attached to the frame

Driver Side Installation Pictured

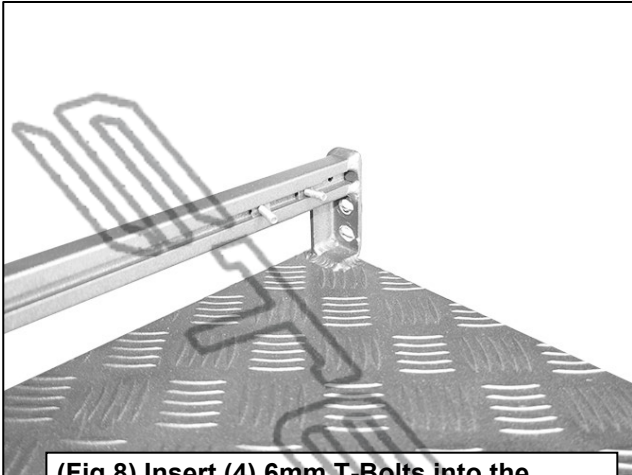

(Fig 8) Insert (4) 6mm T-Bolts into the channel in the rails above the roof platform

- (2) 6mm T-Bolts
- (2) 6mm Flat Washers
- (2) 6mm Lock Washers
- (2) 6mm Hex Nuts

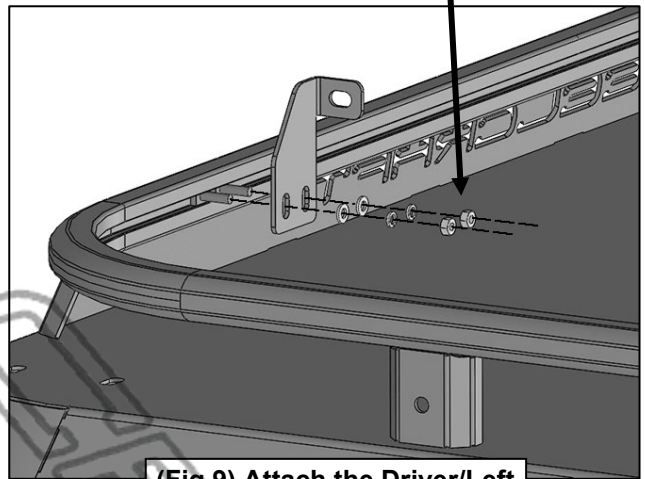

(Fig 9) Attach the Driver/Left Light Bracket to the T-Bolts

- 8mm x 16mm Hex Bolt
- 8mm Lock Washer
- 8mm Flat Washer

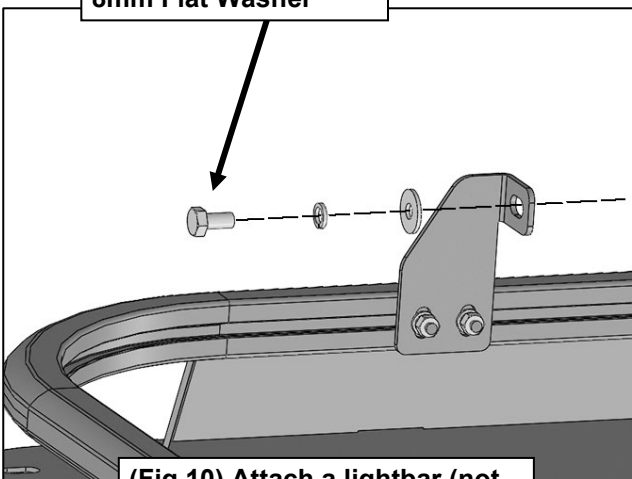

(Fig 10) Attach a lightbar (not included) to the Light Brackets



Driver Side Installation Pictured

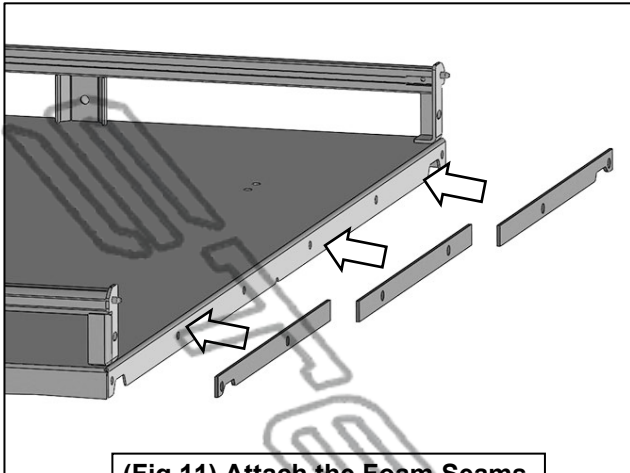

(Fig 11) Attach the Foam Seams to the Front Roof Platform

- (3) 8mm Button Head Bolts
- (6) 8mm Flat Washers
- (3) 8mm Lock Washers
- (3) 8mm Hex Nuts

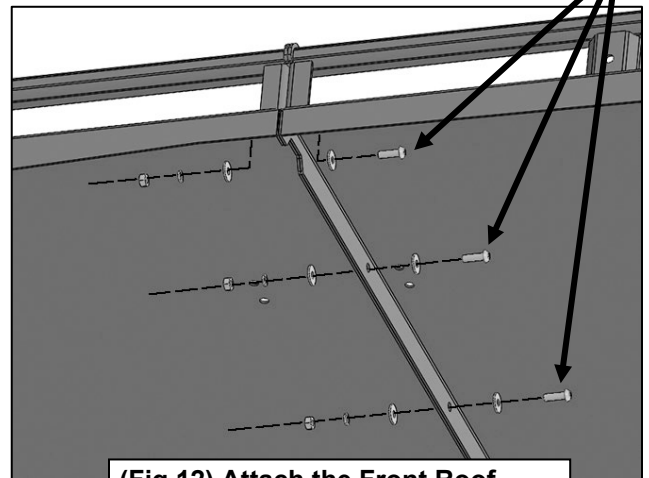

(Fig 12) Attach the Front Roof Platform to the Rear Roof Platform

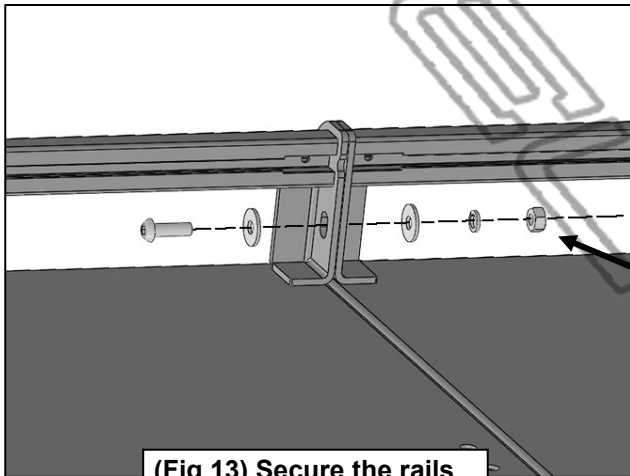

(Fig 13) Secure the rails above the Roof Platforms

- 8mm Button Head Bolt
- (2) 8mm Flat Washers
- 8mm Lock Washer
- 8mm Hex Nut

- (4) 8mm Button Head Bolts
- (8) 8mm Flat Washers
- (4) 8mm Lock Washers
- (4) 8mm Hex Nuts

- (4) 8mm Button Head Bolts
- (4) 8mm Lock Washers
- (4) 8mm Flat Washers
- (4) 8mm Nut Plates

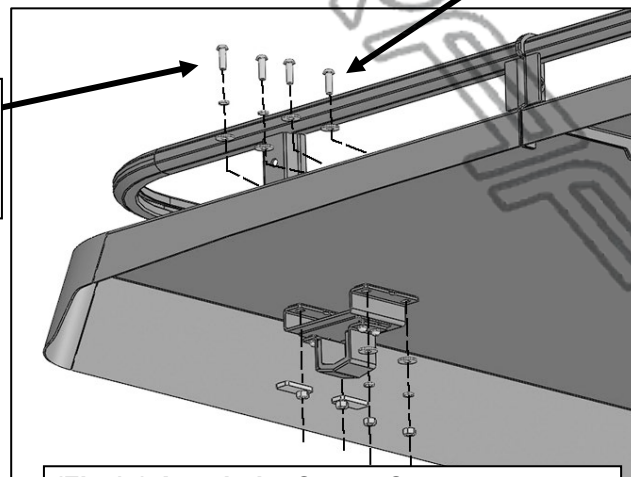

(Fig 14) Attach the Center Connector Bracket to the bottom of the Roof Platforms

Driver Side Installation Pictured

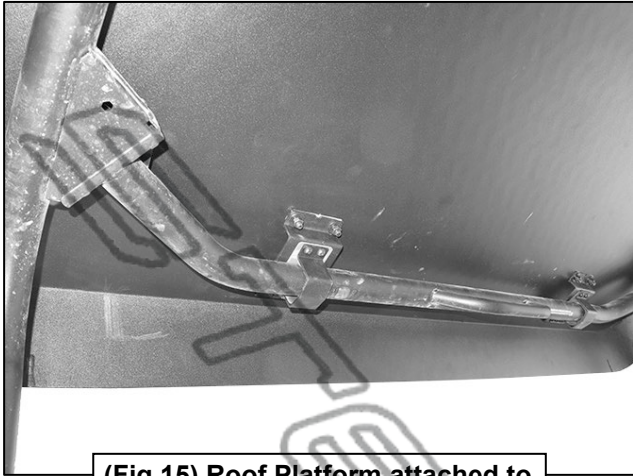

(Fig 15) Roof Platform attached to the front (2) Mounting Brackets

- (4) 8mm Button Head Bolts
- (8) 8mm Flat Washers
- (4) 8mm Lock Washers
- (4) 8mm Hex Nuts

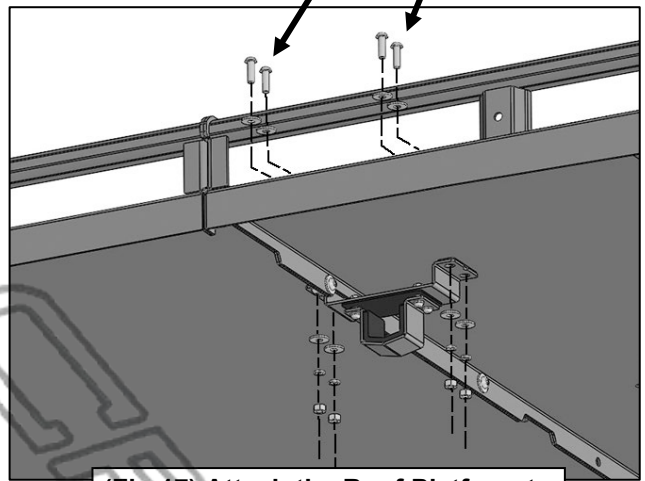

(Fig 17) Attach the Roof Platform to the (3) Center Connector Brackets

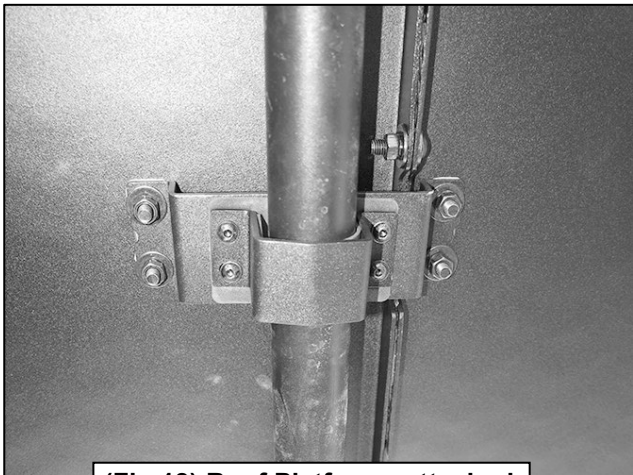

(Fig 18) Roof Platforms attached to (1) Center Connector Bracket