

PARTS LIST:

| | | | |
|---|----------------------------------|----|--------------------------------|
| 1 | Bull Bar | 4 | 10mm x 40mm Hex Bolts |
| 1 | Driver/Left Mounting Bracket | 4 | 10mm x 35mm Hex Bolts |
| 1 | Passenger/Right Mounting Bracket | 16 | 10mm x 27mm x 3mm Flat Washers |
| 2 | 2022-on Bracket Spacer | 8 | 10mm Nylon Lock Nuts |
| 4 | 10mm x 50mm Hex Bolts | | |

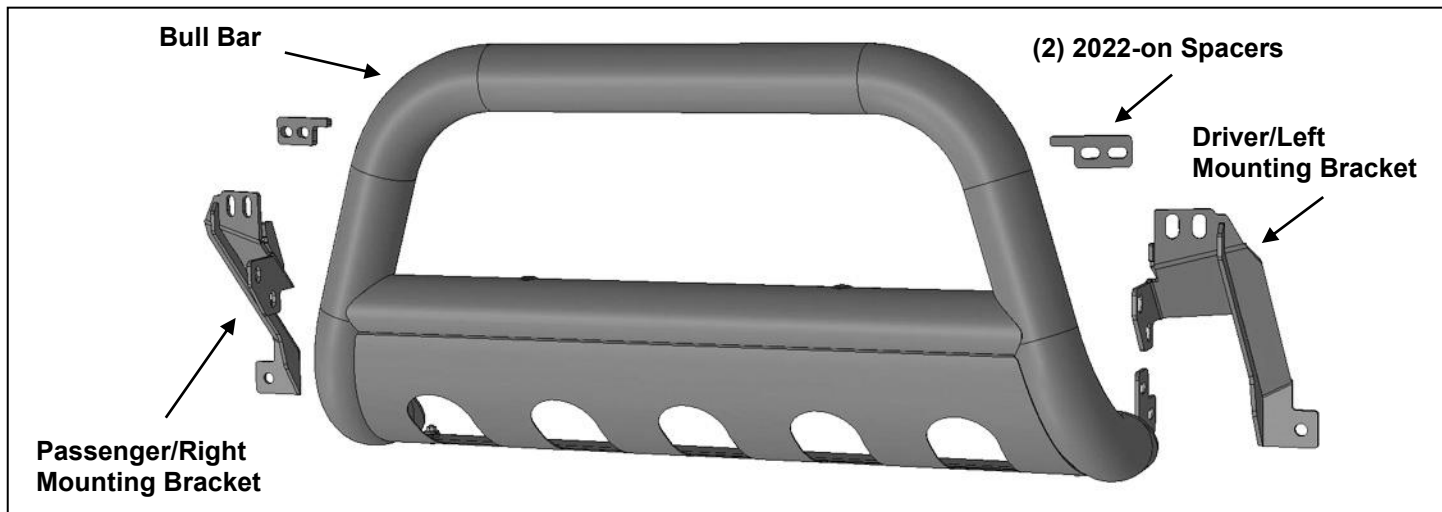

PROCEDURE:

REMOVE CONTENTS FROM BOX. VERIFY ALL PARTS ARE PRESENT. READ INSTRUCTIONS CAREFULLY BEFORE STARTING INSTALLATION. CUTTING IS REQUIRED. INSTALLATION MAY INTERFERE WITH BUMPER MOUNTED PARKING SENSORS AND CAMERA. ASSISTANCE IS RECOMMENDED.

1. Starting at the front of the vehicle, open the hood and remove the (8) bolts from the top of the plastic bumper cover, **(Figure 1)**.
2. Move to the driver/left front wheel opening. Remove the hardware attaching the fender liner to the bumper cover and end of front fender, **(Figure 2)**. Remove the screws attaching the bottom of the bumper cover to the fender liner, **(Figure 3)**.
3. Remove the hardware attaching the bottom of the bumper to the vehicle, **(Figure 4)**.
4. Firmly pull the end of the fender flare from the fender and bumper, **(Figure 5)**. Don't remove the entire flare, only release the forward end attached to the bumper cover and end of fender.
5. Move to the passenger/right side of the vehicle. Repeat **Steps 2—4** to release the fender liner and fender flare. Pull back the liner and unplug all wiring harnesses leading to the front bumper cover, **(Figure 6)**.
6. From inside the wheel well, locate and remove the (3) bolts attaching the passenger/right side of the bumper to the end of the fender, **(Figure 7)**. Repeat this **Step** to release the driver/left side of the bumper.
7. Unplug both headlights, **(Figure 8)**. Release the clip attaching the rear of each headlight assembly to the front end of the fender, **(Figure 9)**.
8. With assistance, pull the ends of the bumper cover to release from clips and carefully remove the front bumper, grille and headlights as an assembly from the front of the vehicle, **(Figures 9 & 10)**. Place the bumper on a soft, clean surface.
9. **Determine year of vehicle:**
 - 2021 models**
 - a. Remove the outer flange nut from driver/left end of the lower crossmember, **(Figures 11 & 12)**.
 - b. Select the driver/left Mounting Bracket, **(Figure 13)**.
 - c. Attach the top of the Bracket directly to the outside of the flat mounting tab on the bottom of the impact bumper with (2) 10mm x 40mm Hex Bolts, (4) 10mm Flat Washers and (2) 10mm Nylon Lock Nuts, **(Figure 13)**.

d. Reuse the factory flange nut to attach the bottom of the Mounting Bracket to the outer end of the lower crossmember, **(Figure 13)**.

e. Repeat previous **Steps** to attach the passenger/right Mounting Bracket. Fully tighten hardware.

2022-on models:

a. Remove the outer flange nut from driver/left end of the lower crossmember, **(Figures 11 & 12)**.

b. Select the driver/left Mounting Bracket and (1) Top Bracket Spacer, **(Figure 14)**.

c. Insert the Spacer between the top of the Bracket and the mounting tab on the bottom of the impact bumper. Attach the Bracket and Spacer to the tab with the included longer (2) 10mm x 50mm Hex Bolts, (4) 10mm Flat Washers and (2) 10mm Nylon Lock Nuts, **(Figures 14 & 15)**.

d. Reuse the factory flange nut to attach the bottom of the Mounting Bracket to the outer end of the lower crossmember, **(Figure 15)**.

e. Repeat previous **Steps** to attach the passenger/right Mounting Bracket.

10. Attach the Bull Bar to the Mounting Brackets with (4) 10mm Hex Bolts, (8) 10mm Flat Washers and (4) 10mm Hex Nuts, **(Figure 16)**. Do not tighten hardware.

11. Level and adjust the Bull Bar and tighten **ONLY** the Mounting Bracket to vehicle hardware.

12. Move to the driver/left pocket next to the lower radiator opening in the bumper cover, **(Figure 17)**. Use removable tape to cover the pocket. Mark a 3/4" wide by 4" tall rectangle onto the left/inner edge of the pocket. Repeat this **Step** to mark the passenger/right pocket. **NOTE:** Measurements are given as a starting location reference only. For best results, use a sharp knife or hacksaw blade to carefully cut the slots to clear the Brackets. Start with a small slot smaller than the Brackets and slowly enlarge the slot to clear the Brackets.

13. Temporarily remove the Bull Bar from the Mounting Brackets. Reattach the bumper cover and fender flares to the vehicle after it has been trimmed to clear the Brackets, **(Figure 18)**. Plug in wiring harness and headlights.

14. Reattach the Grille Guard and tighten all hardware.

15. Do periodic inspections to the installation to make sure that all hardware is secure and tight.

To protect your investment, Do not use any type of polish or wax that may contain abrasives that could damage the finish. Mild soap may be used to clean the Bull Bar.

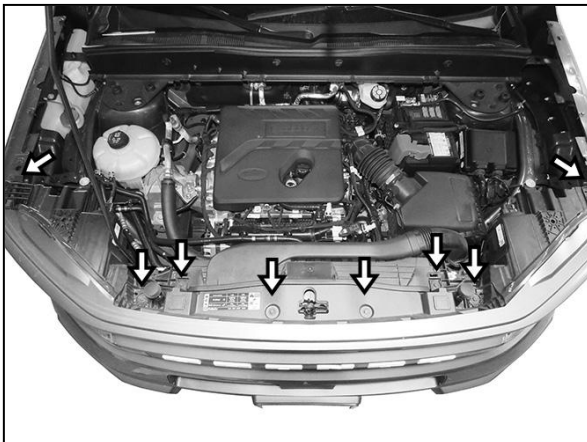

(Fig 1) Remove the hardware attaching the top of the bumper cover. Also unplug both headlights. Driver/left side pictured to show mounting hardware and locations

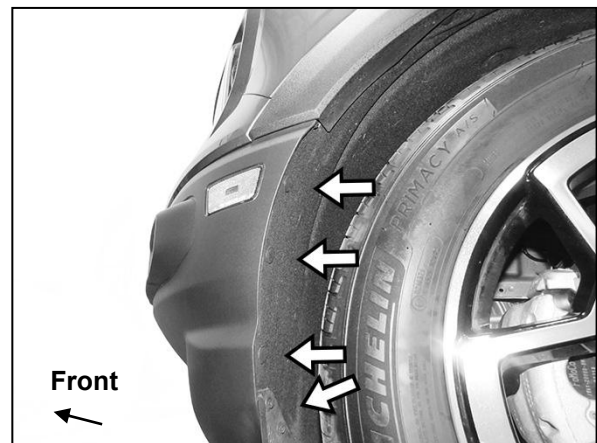

(Fig 2) Remove the hardware attaching the fender liner to the front bumper (arrows)

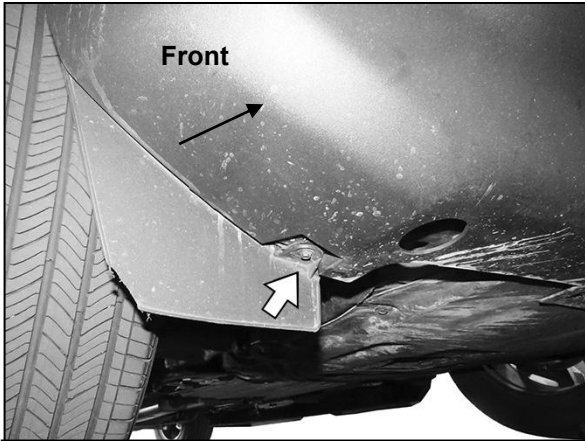

(Fig 3) Remove screws attaching bottom of bumper cover to inner liner (arrow)

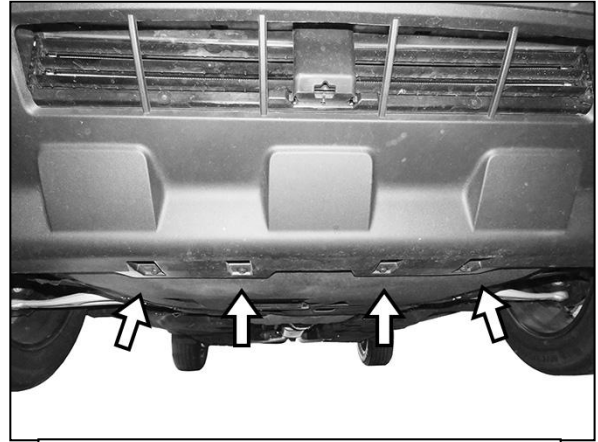

(Fig 4) Remove the hardware attaching the bottom of the bumper to the vehicle



(Fig 5) Firmly pull the front of the fender flare out from the bumper (passenger/right side pictured). Do not remove the flare, only release the front end of the flare



(Fig 6) Unplug the wiring harness leading to the front bumper (passenger/right side pictured).

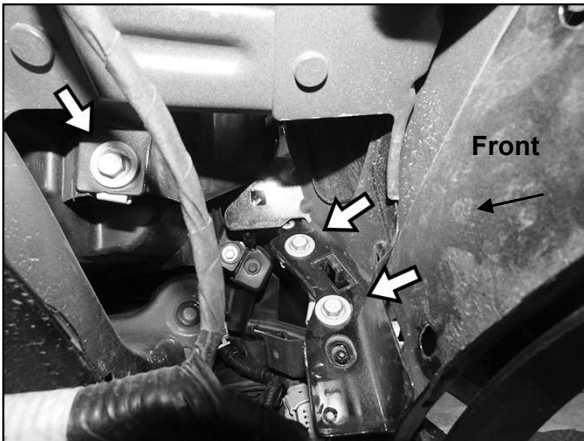

(Fig 7) From inside the fender, behind the bumper, remove hardware attaching the front bumper to the end of the fender, (passenger/right side pictured)

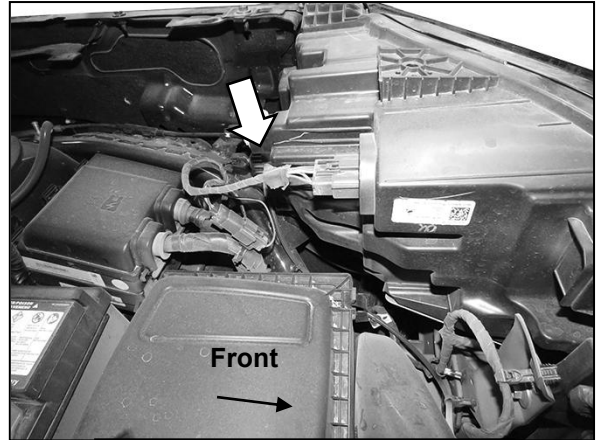

(Fig 8) Unplug both headlights

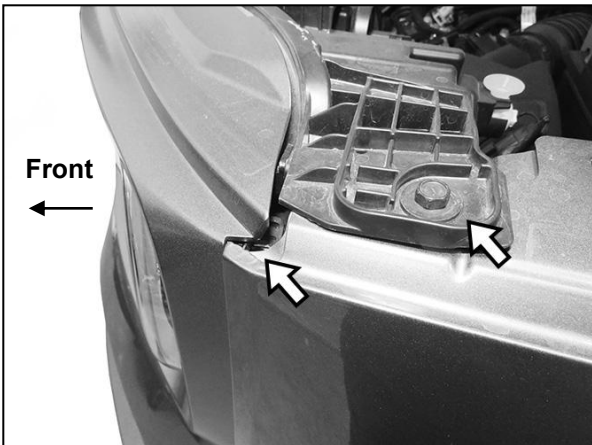

(Fig 9) Remove the hex bolt attaching the headlight assembly to the fender (arrow). Using needle nose pliers or a flat blade screwdriver to release the inner clip and pull the front bumper cover with headlight away from the vehicle (arrow). Driver/left side pictured



(Fig 10) Carefully remove the bumper cover assembly and place it on a clean, soft surface

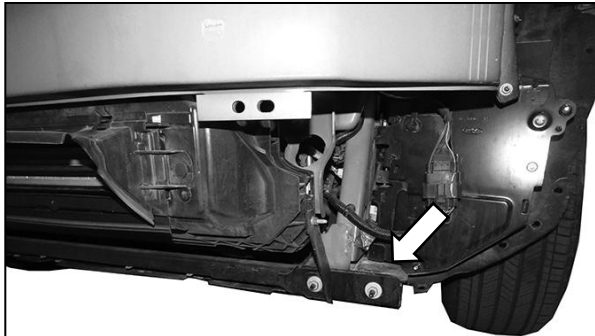

Front

(Fig 11) Temporarily remove the outer nut from the lower crossmember (arrow). Driver/left side pictured

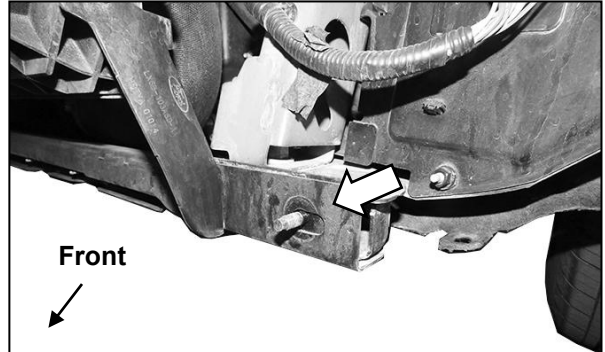

Front

(Fig 12) Temporarily remove the outer nut from the lower. Driver/left side pictured

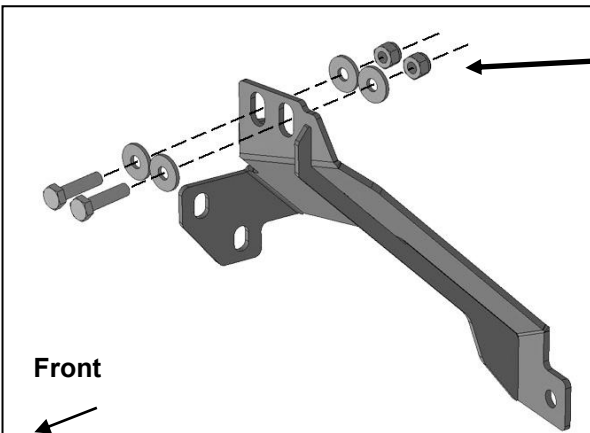

Front

(Fig 13) 2021 models only: Attach driver/left Bracket to mounting tab and crossmember. Reuse the factory hex nut to attach the bottom of the Bracket to the crossmember

- (2) 10mm x 40mm Hex Bolts
- (4) 10mm Flat Washers
- (2) 10mm Nylon Lock Nuts

- (2) 10mm x 50mm Hex Bolts
- (4) 10mm Flat Washers
- (2) 10mm Nylon Lock Nuts

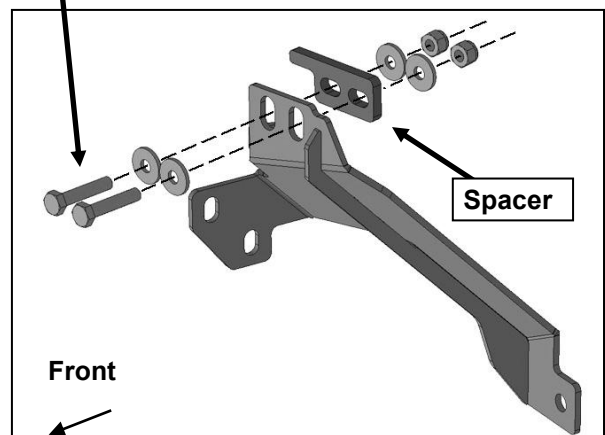

Front

(Fig 14) 2022-on models only: Insert Spacer between top of Bracket and mounting tab. Reuse the factory hex nut to attach the bottom of the Bracket to the crossmember. Driver/left Bracket illustrated.

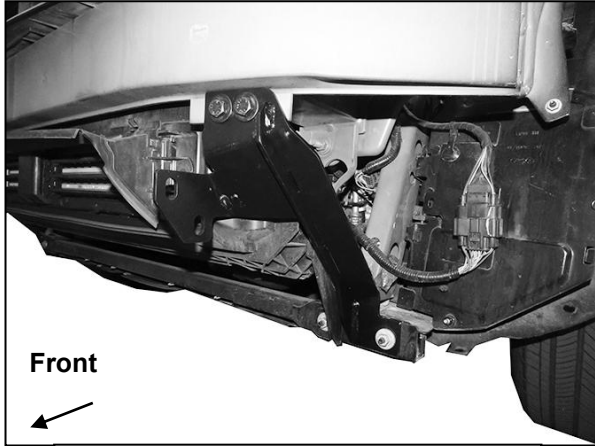

(Fig 15) Driver/left Mounting Bracket attached to the vehicle

- (2) 10mm x 35mm Hex Bolts
- (4) 10mm Flat Washers
- (2) 10mm Nylon Lock Nuts

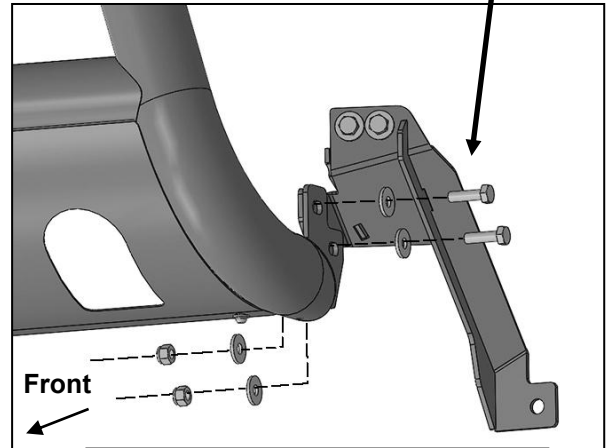

(Fig 16) Attach the Bull Bar to the outside of the Mounting Brackets



(Fig 17) From behind the bumper mark the indicated area with tape. Use a hacksaw or sharp knife to make small cuts to clear Brackets

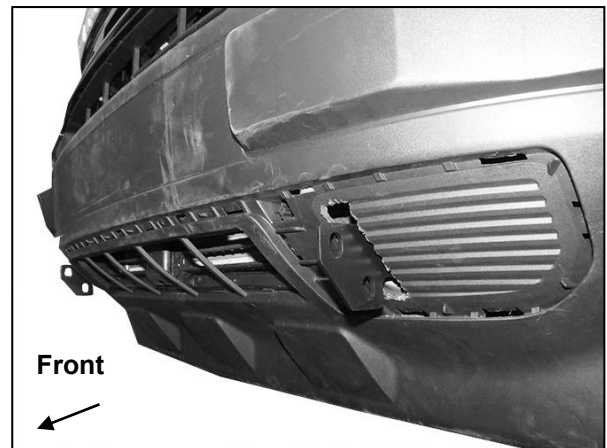

(Fig 18) Reattach the bumper to the vehicle



Complete Installation