

INSTALLATION INSTRUCTIONS

**FORTIS BUMPER
2010-18 RAM 25-3500**

STEELCRAFT

PARTS LIST:

1	Fortis Front Bumper	12	12mm x 37mm x 3mm Flat Washers
1	Driver/left side Frame Bracket	16	12mm x 32mm x 3mm Flat Washers
1	Passenger/right side Frame Bracket	8	12mm Lock Washers
1	Driver/left side LED Light "L" Bracket	8	12-1.75mm Hex Nuts
1	Passenger/right side LED Light "L" Bracket	6	12mm Nylon Lock Nuts
2	License Plastic Plugs	2	8-1.25mm x 25mm Hex Bolts
3	Dodge Wiring Harnesses	2	8-1.25mm x 16mm Hex Bolts
6	Retaining Ring	6	8mm x 24mm x 2mm Flat Washers
6	Centering Foam Washers	4	8mm Lock Washers
6	Sensor Hole Plugs	2	8-1.25mm Hex Nuts
1	Sensor Cover Kit	12	4-0.75mm x 10mm Button Head Bolts
14	12-1.75mm x 50mm Hex Bolts	1	2.5mm Allen Wrench

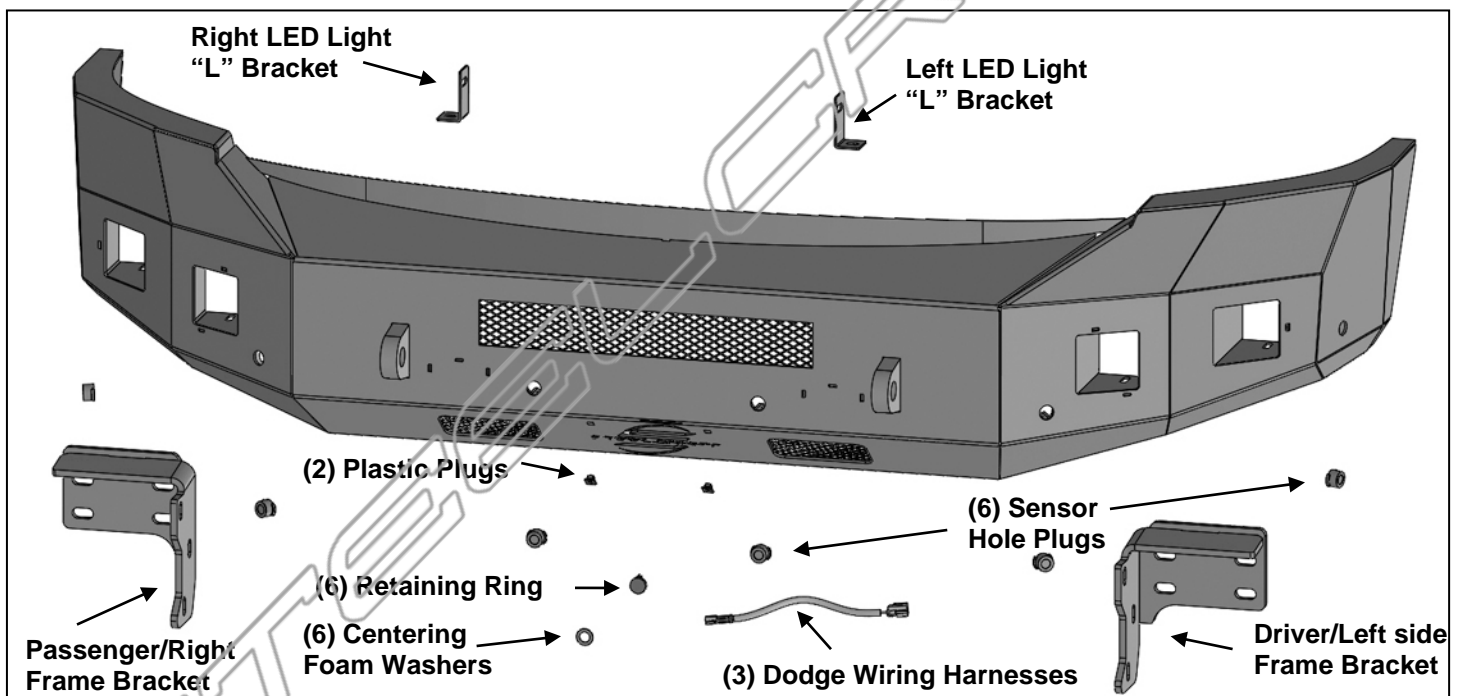

PROCEDURE:

REMOVE CONTENTS FROM BOX. VERIFY ALL PARTS ARE PRESENT. READ INSTRUCTIONS CAREFULLY BEFORE STARTING INSTALLATION. BUMPER IS HEAVY, ASSISTANCE IS HIGHLY RECOMMENDED TO AVOID POSSIBLE INJURY OR DAMAGE TO THE VEHICLE. CUTTING MAY BE REQUIRED.

1. Remove the license plate and bracket. On models with factory fog lights and/or sensors, unplug wiring harness, **(Figure 1)**. Release the harness from the clips attached to the back of the bumper and move harness away from bumper.
2. Next, open hood and remove the plastic cover between the top of the grille and the top of the radiator. Carefully remove the grille assembly, **(Figures 2 & 3)**.
3. Place blocks or jack stands under the front bumper to support it during mounting bolt removal. Once the bumper has been safely supported, remove the hex nuts attaching each bumper bracket to the end of the frame, **(Figure 4)**. **WARNING!** Assistance is required to hold the bumper in place during hardware removal to prevent the bumper from falling. Slide the bumper assembly off of the tow hooks.
4. Next, remove the tow hooks from the ends of the frame, **(Figures 5 & 6)**.

5. Select the driver/left side Frame Bracket. Attach the Bracket to the end of the frame with (4) 12mm x 50mm Hex Bolts, (8) 12mm x 32mm Flat Washers, (4) 12mm Lock Washers and (4) 12mm Hex Nuts, **(Figure 7)**. Leave hardware loose. Repeat this Step to install the passenger side Frame Bracket.
6. **Optional Center LED light installation**, (sold separately). **NOTE:** Light must be installed in Bumper before Bumper Assembly is attached to the Brackets.
 - a. Select the L/R “L” Brackets, **(Figure 8)**. **NOTE:** “L” Brackets are offset for universal fitment for most LED bar style lights. Attach the LED light assembly to the “L” Brackets with the included (2) 8mm x 16mm Hex Bolts, (2) 8mm Lock Washers and (2) 8mm Flat Washers, **(Figure 8)**. Do not fully tighten hardware at this time. **NOTE:** “L” Brackets may require modification for hardware larger than 8mm or use brackets supplied with light if possible.
 - b. Attach the light and brackets to the top of the (2) tabs on the back of the Bumper with the included (2) 8mm x 25mm Hex Bolts, (4) 8mm Flat Washers, (2) 8mm Lock Washers and (2) 8mm Hex Nuts, **(Figure 8)**. Adjust light position and tighten hardware.
 - c. Follow light manufacturer’s instructions to wire the light to the vehicle’s electrical system once Bumper has been fully installed.
7. **NOTE:** Sensors, (if equipped), must be installed in Bumper before Bumper is attached to Brackets.

Models without bumper sensors:

- a. Select the included (6) Rubber Plugs.
- b. From behind bumper, push plugs into sensor mounting holes.

Models with bumper mounted sensors:

- a. Remove sensors from back of OE Bumper.
 - b. Remove factory sealing washer from sensor. Slide the provided Foam Washer onto the front of the sensor, **(Figure 9)**.
 - c. Push the sensor in from the back of the Bumper until it is flush with the sensor sleeve. **NOTE:** Sensor tabs may need to be trimmed to fit sensor inside sensor sleeve. Push (1) Retaining Ring into the sensor sleeve to secure the sensor in place, **(Figure 10)**.
 - d. Repeat the previous steps for the remaining sensors.
 - e. Starting on the driver side, run the OE sensor wire harness through the bumper cutouts. Connect the first three driver side sensors to the OE sensor wire harness.
 - f. Use the provided wire harness extensions to connect the remaining three passenger side sensors to the OE sensor wire harness.
8. If front license plate is required, insert (2) Plastic Plugs into the square holes in the front of the Bumper, **(Figure 11)**. Reuse the factory screws to attach the license plate to the plastic plugs.
 9. With assistance, position the Bumper Assembly up to the insides of the Frame Brackets. Temporarily support the weight of the Bumper. **WARNING:** To avoid possible injury or damage to the vehicle, do not proceed until the Bumper is fully and safely supported.
 10. Attach the Bumper to the inside of the Frame Brackets with (6) 12mm x 50mm Hex Bolts, (12) 12mm x 37mm Flat Washers and (6) 12mm Nylon Lock Nuts, **(Figures 12 & 13)**. Do not fully tighten hardware.
 11. Reattach the main wiring harness to the bumper sensors, if equipped.
 12. **LED light installation at ends of bumper** (sold separately).
 - a. Insert light into opening and up to mounting slots. Check for clearance between front and back of light, **(Figure 14)**.
 - b. Follow the light manufacturer’s instructions to attach each light to slot in the bottom of the light opening. **IMPORTANT:** On two light systems, attach the flood light to the outer slot and the spot light to the inner slot.
 - c. Repeat the above steps for passenger side light installation.
 - d. Follow light manufacturer’s instructions to properly wire the light to the vehicle electrical system.
 13. Level and adjust the bumper and fully tighten all hardware.
 14. Do periodic inspections to the installation to make sure that all hardware is secure and tight.

To protect your investment, wax this product after installing. Regular waxing is recommended to add a protective layer over the finish. Do not use any type of polish or wax that may contain abrasives that could damage the finish. Mild soap may be used to clean the Bumper assembly.

Driver Side Installation Pictured

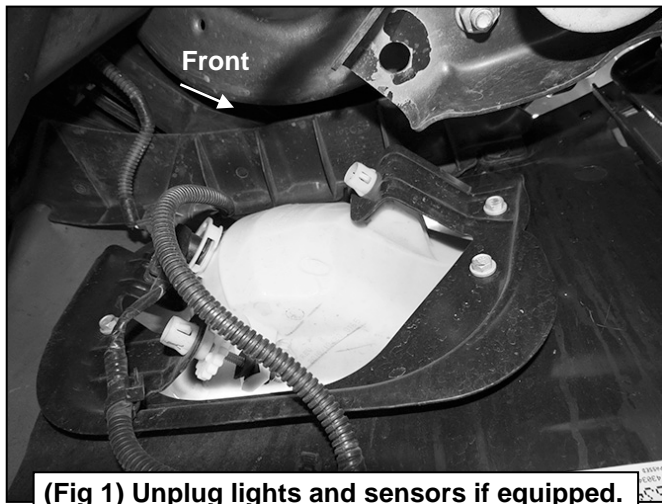

(Fig 1) Unplug lights and sensors if equipped. Unplug harness to bumper and move harness

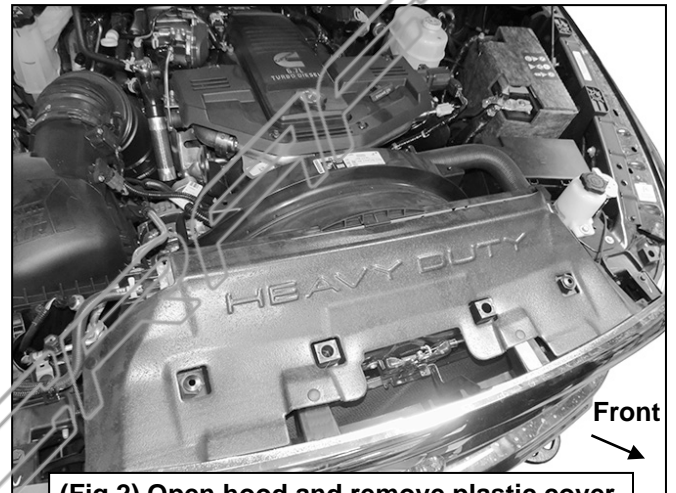

(Fig 2) Open hood and remove plastic cover

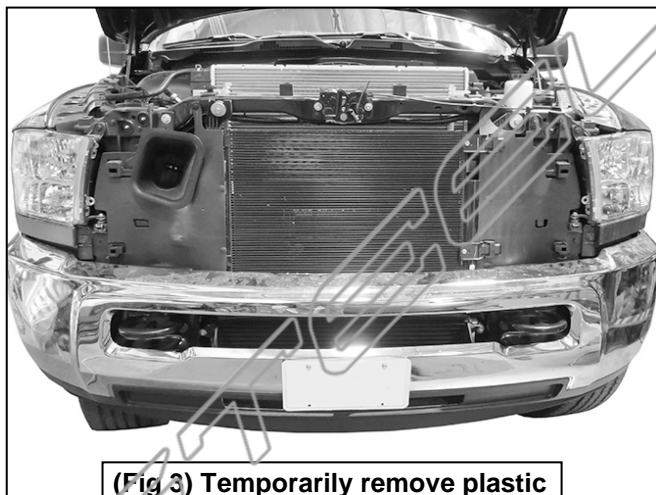

(Fig 3) Temporarily remove plastic grille to access top bumper bolts

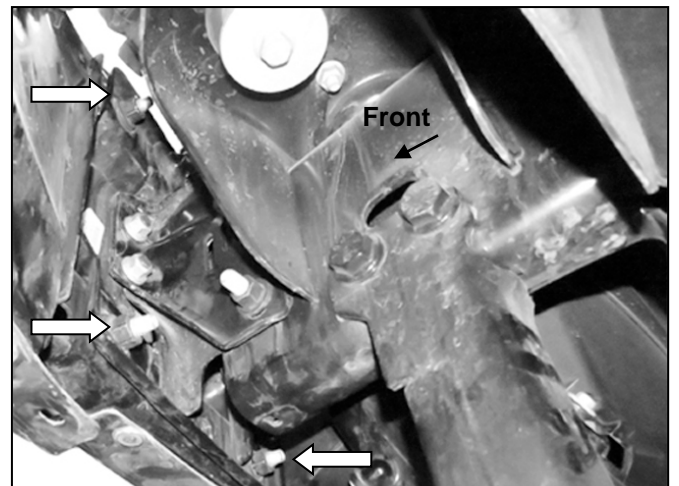

(Fig 4) Remove hex nuts from bumper bolts (arrows). Bumper bracket pictured from below/behind bumper

WARNING! Do not remove bumper bolts unless the bumper is properly supported on blocks or stands or the bumper may fall.

Driver Side Installation Pictured

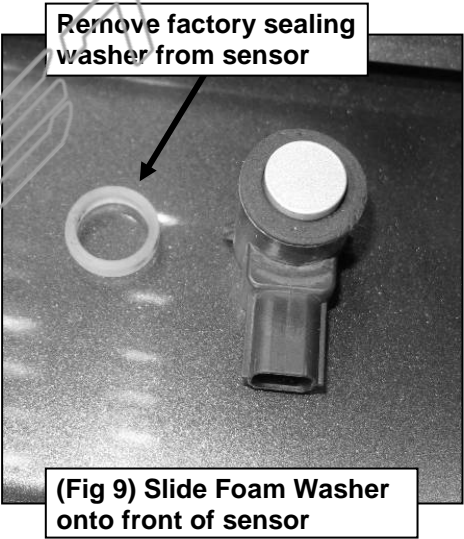
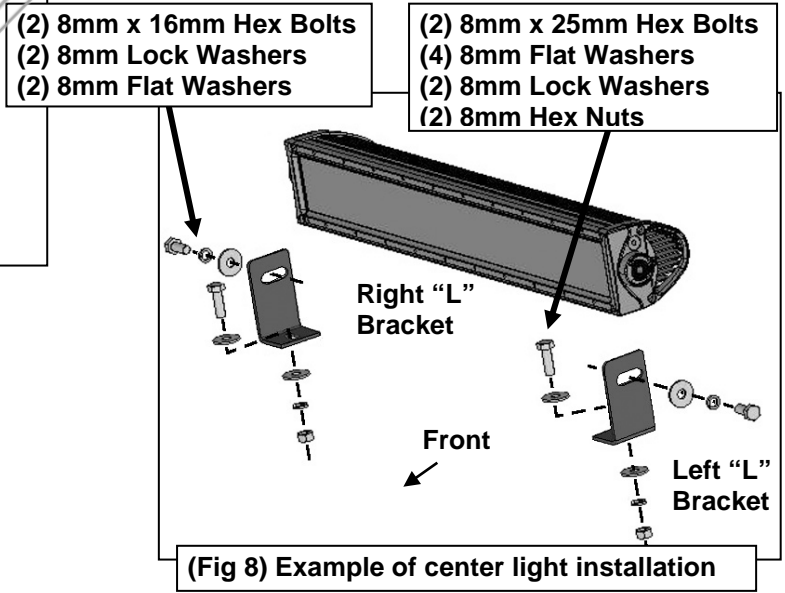
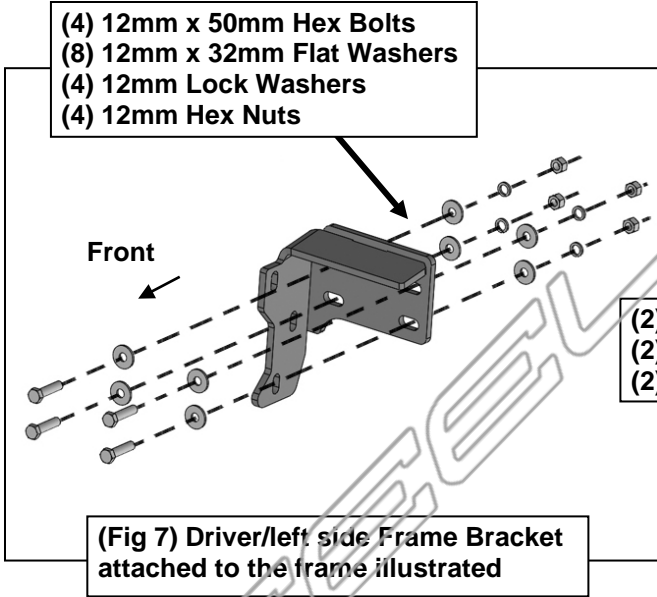
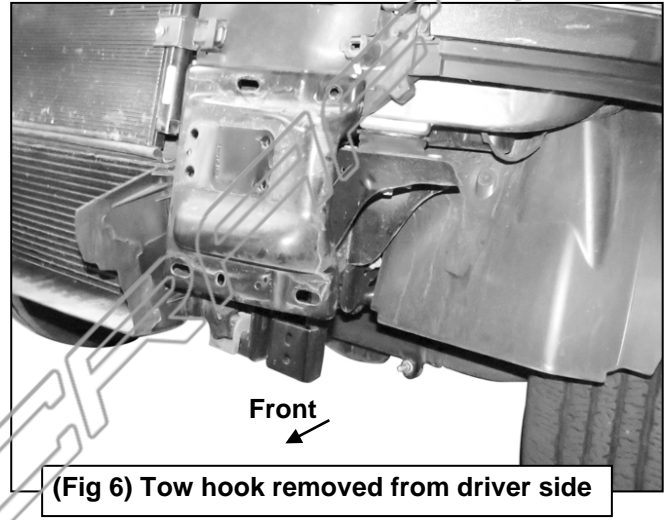
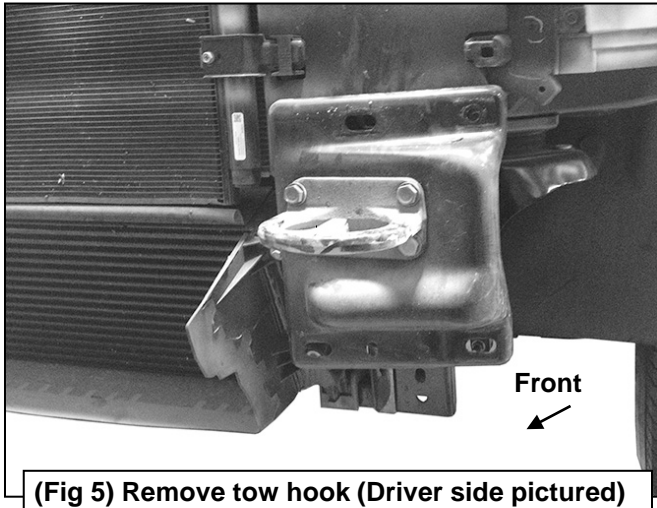

Driver Side Installation Pictured

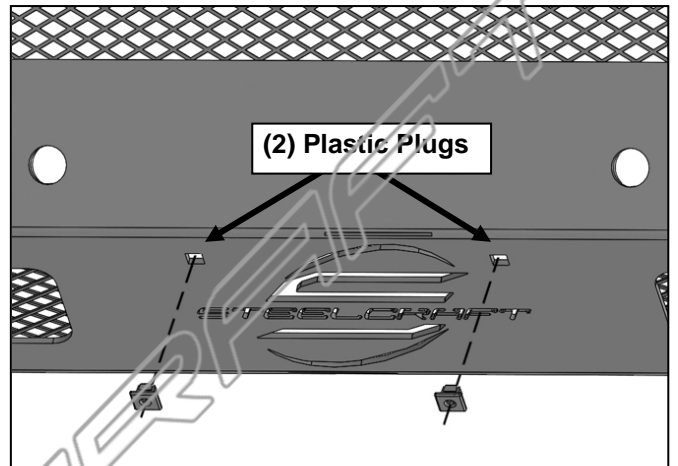
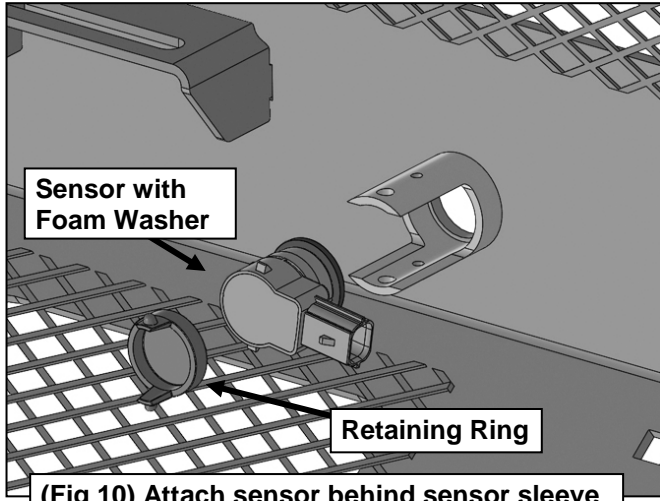

WARNING! Do not crawl under bumper unless the bumper is properly supported on blocks or stands or the bumper may fall.

