

INSTALLATION INSTRUCTIONS

UNIVERSAL HEADACHE RACK

STEELCRAFT

PARTS LIST:

1	Headache Rack	2	Special 10mm "J" Bolts
1	Driver Mounting Base	6	10-1.5mm x 40mm Hex Bolts
1	Passenger Mounting Base	6	10mm x 34mm OD x 3mm Flat Washers
4	12-1.75mm x 40mm Hex Bolts	12	10mm x 24mm OD x 2.2mm Flat Washers
10	12mm x 37mm OD x 3mm Flat Washers	6	10mm Lock Washers
4	12mm Lock Washers	6	10mm Hex Nuts
4	12mm Hex Nuts	4	10mm Plastic Insulating Washers (Use with Ford aluminum beds only)

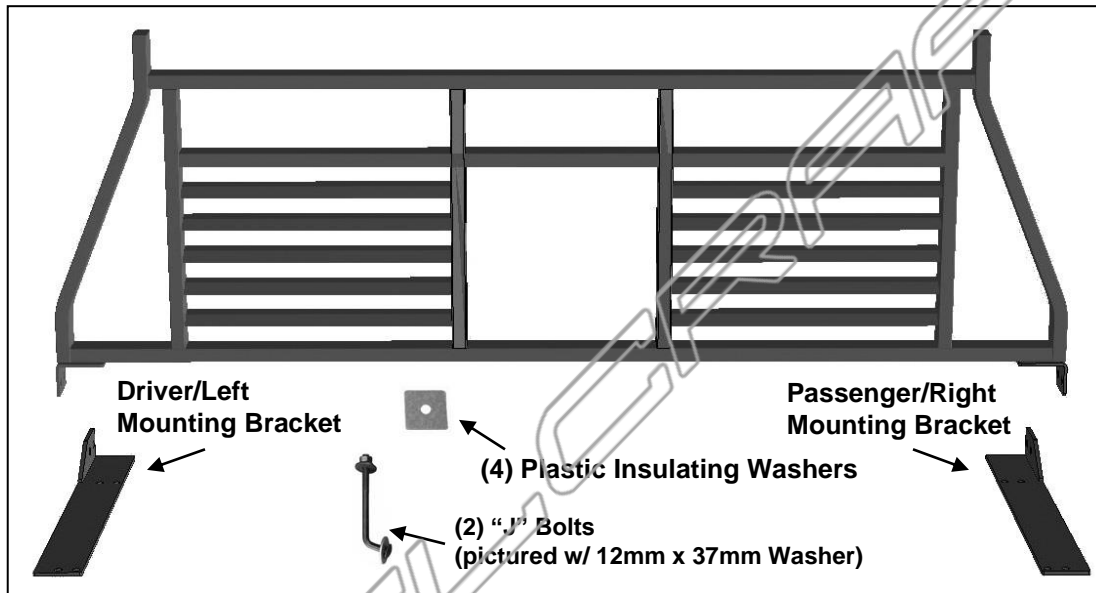

- 1. REMOVE CONTENTS FROM BOX. VERIFY ALL PARTS ARE PRESENT. READ INSTRUCTIONS CAREFULLY BEFORE STARTING INSTALLATION. DRILLING IS REQUIRED. ASSISTANCE IS RECOMMENDED. CUTTING OF PLASTIC BED LINER (IF EQUIPPED) MAY BE REQUIRED.**
- Select the passenger side Mounting Bracket. Bolt the Bracket to the outside of the tab on the right side of the Headache Rack with (2) 12mm x 40mm Hex Bolts, (4) 12mm Flat Washers, (2) 12mm Lock Washers and (2) 12mm Hex Nuts, **(Figure 1)**. Snug but do not fully tighten hardware at this time. Repeat to attach the driver side Mounting Bracket. **IMPORTANT:** The Mounting Brackets can be attached to the outside or inside of the Headache Rack if width adjustment is required, **(Figures 1 & 10)**. The Brackets can also be switched side to side for additional Rack width if desired.
- With assistance, carefully place the Headache Rack onto the approximate mounting position at the front of the truck bed. Line up the forward end of the Brackets with the end of the bed. Adjust the width of the Brackets for best fit on the truck bed as described in **Step 2**.
- Determine if the forward holes in the Brackets line up with the front stake pockets. **NOTE:** On some vehicles, the front stake pocket may be covered with a plastic bed cap. Remove or cut out the cover as required to gain access to the stake pocket **only** if using "J" Bolts, **(Figures 2—4)**.

Bracket lines up with the stake pocket-use 10mm "J" Bolt if possible:

 - Select (1) 10mm "J" Bolt and (1) 12mm Flat Washer, **(Figure 3)**. Slide the Flat Washer over the "J" Bolt down to the head on the bolt. Insert the "J" Bolt into the hole in the side of the stake pocket, (if equipped), and up through the Bracket, **(Figure 4)**.
 - Secure the Bracket to the "J" Bolt with (1) 10mm Small Flat Washer, (1) 10mm Lock Washer and (1) 10mm Hex Nut. Do not fully tighten hardware at this time.
 - Repeat to install the passenger side "J" Bolt.
 - NOTE:** If "J" Bolt does not reach Bracket or cannot be installed, (no hole in stake pocket), do not use the "J" Bolts and Skip to **Step 5**.

Do not attach the Headache Rack with only the "J" Bolts! Additional hardware is required and drilling is mandatory.

5. With the Headache Rack properly positioned on the top of the bed, locate the best location to drill. Use the provided holes in the Brackets if possible, **(Figure 5)**. Do not drill the top of the bed until you have made absolutely sure that you can gain access to the bottom of the mounting locations. **(Figure 6)**.
 - a. Use the pre-punched holes in the Bracket if possible. If you are using the "J" Bolts, only mark the rear mounting location on the top of the bed, **(Figure 5)**. If "J" Bolts are not used, mark the forward and rear mounting locations.
 - b. Each mounting Bracket has (2) pairs of mounting holes. Use the holes to the center of the Bracket if possible to better support the Headache Rack, **(Figure 7)**.
6. Once all locations have been checked and the holes marked on the top of the bed, remove the Headache Rack assembly. **IMPORTANT:** Do not drill too close to the edge of the top of the bed.
7. Drill the required holes as marked with a 7/16" drill bit. Bolt the Bracket to each mounting hole with (1) 10mm Hex Bolt, (2) 10mm Flat Washers, (1) 10mm Lock Washer and (1) 10mm Hex Nut, **(Figures 7 & 10)**. **NOTE:** Use the larger Washers under the top of the bed if possible. Smaller 10mm Flat Washers have also been provided if there is insufficient room.

IMPORTANT SPECIAL NOTE for 2015-on Ford F150, 2016-on Ford F250-450 only: (4) 10mm Plastic Washers have been included to insulate the aluminum bed from the steel 10mm Flat Washers. Insert the Plastic Washers between the underside of the bed and the 10mm Flat Washer, **(Figure 10)**.

8. The provided mounting holes in the Brackets will allow installation on most but not all vehicles. If the holes are not in the correct location for your particular model, drill new mounting holes through the Bracket and top of the bed as necessary for the best possible fit, **(Figures 8 & 9)**.
9. On some models, the location of the inner stake pocket interferes with the forward mounting holes. For added support, drill an additional hole at the front of the Bracket, **(Figures 8 & 9)**. Additional hardware has been provided to bolt the Brackets to the front of the bed for (3) locations per Bracket if desired.
10. Center the Headache Rack on the truck, check the alignment and tighten all hardware.
11. Do periodic inspections to the installation to make sure that all hardware is secure and tight.

To protect your investment, wax this product after installing. Regular waxing is recommended to add a protective layer over the finish. Do not use any type of polish or wax that may contain abrasives that could damage the finish.

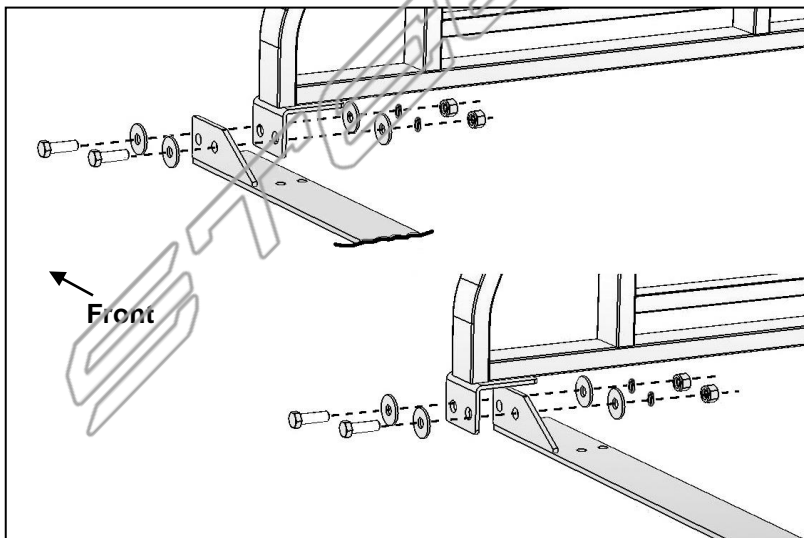

(Fig 1) Mounting Brackets can be bolted to the inside or outside of the mounting tab on the Headache Rack to accommodate different truck bed widths

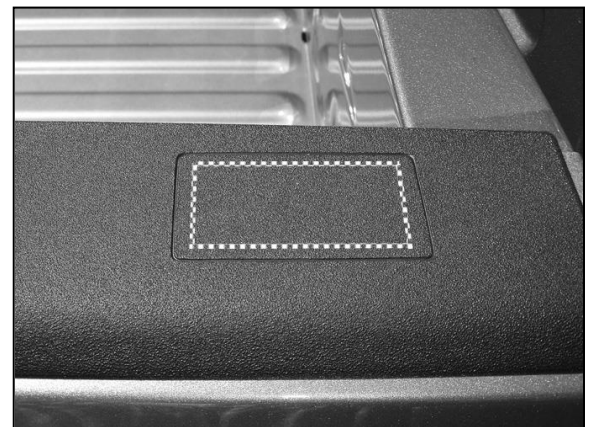

(Fig 2) Remove plug or cut out opening in plastic bed cap as necessary



(Fig 3) 10mm "J" Bolt w/12mm Flat Washer



(Fig 4) Use the "J" Bolt to secure the front mounting holes on the Bracket to the stake pocket if possible. Do not drill any mounting holes until after all mounting locations are checked for clearance

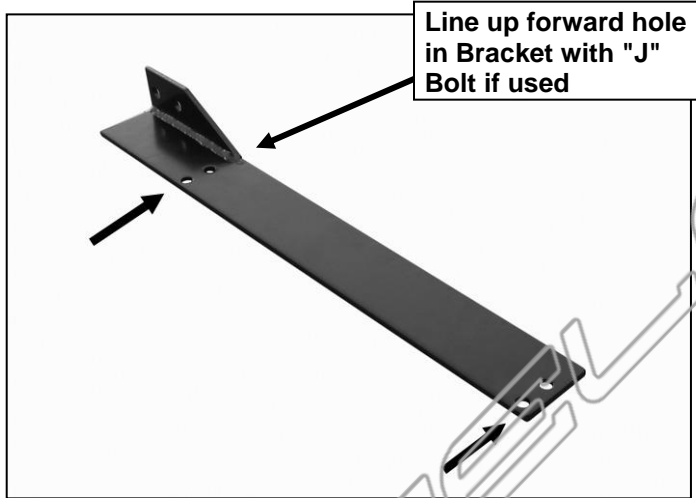

Line up forward hole in Bracket with "J" Bolt if used

(Fig 5) Insert 10mm "J" Bolt with (1) 12mm Flat Washer into hole in side of stake pocket and up through opening and forward hole in the Bracket.



(Fig 6) Before drilling any holes through the top of the bed, check the bottom of the top edge of the bed for hardware clearance.

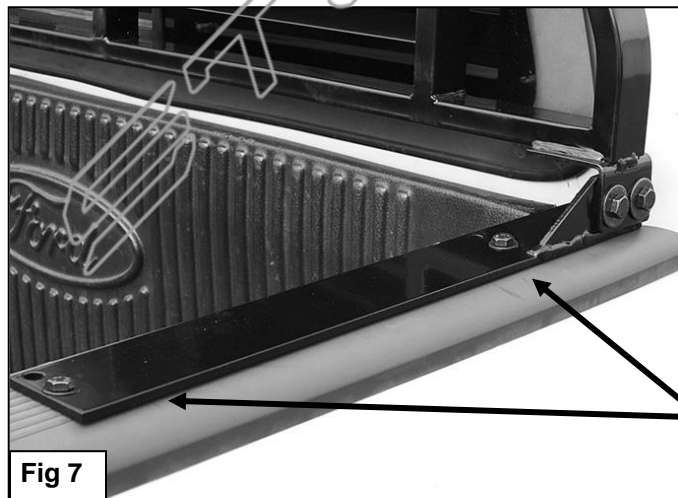

- (2) 12mm Hex Bolts
- (4) 12mm Flat Washers
- (2) 12mm Lock Washers
- (2) 12mm Hex Nuts

- 10mm Hex Bolt
- 10mm Small Flat Washer (top)
- 10mm Large Flat Washer (bottom)
- 10mm Lock Washer
- 10mm Hex Nut

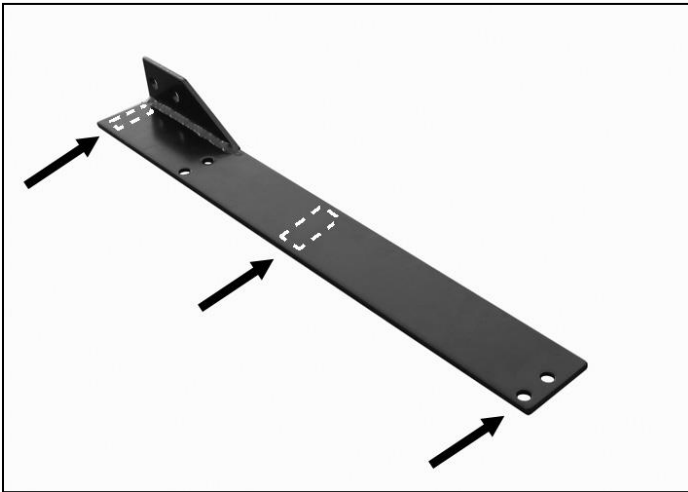

(Fig 8) If the forward hole in the Bracket does not line up with the stake pocket or the J Bolt will not fit properly, drill the necessary holes and bolt the Bracket directly to the top of the bed.

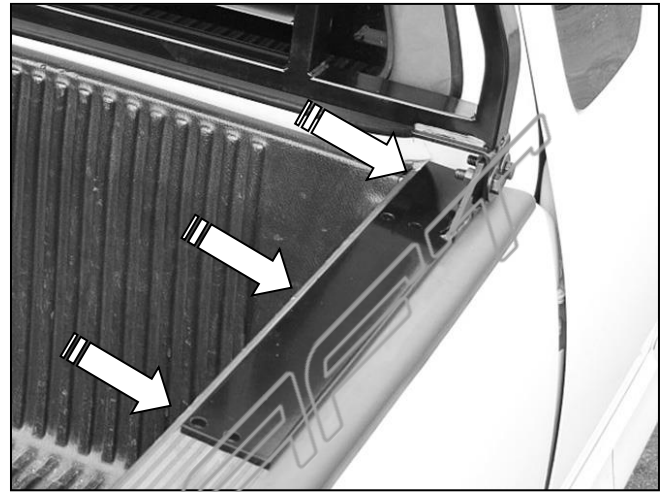

(Fig 9) Optional "3-Bolt" per side installation pictured.

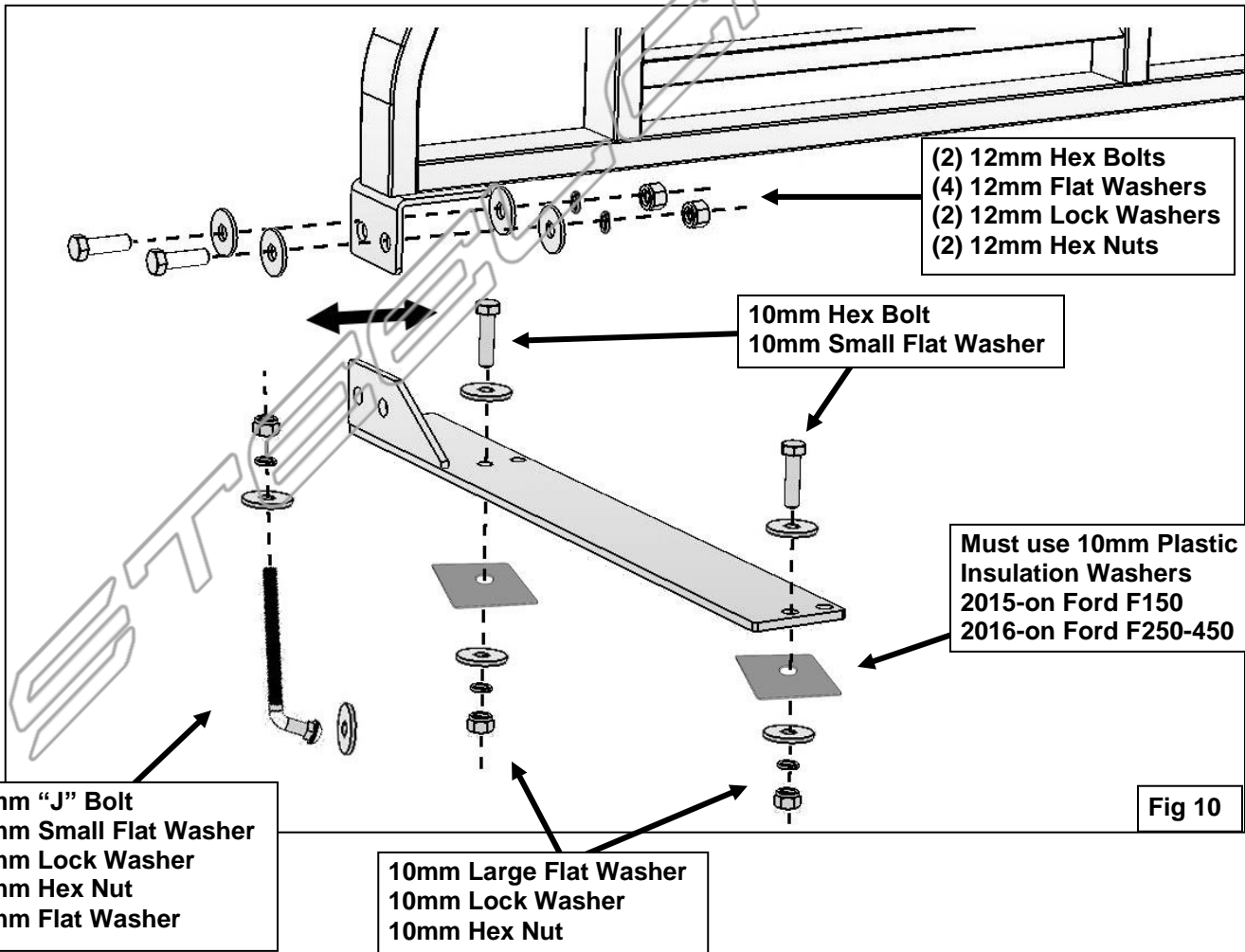

Fig 10