

**ALUMINUM VIEWPOINT RUNNING BOARDS
2009-13 DODGE JOURNEY**

PARTS LIST:

1	Driver/Left Running Board	4	12mm Hex Nuts
1	Passenger/Right Running Board	2	10mm Lock Washers
1	Driver/Left Front Mounting Bracket	2	10mm x 30mm x 2.5mm Flat Washers
1	Passenger/Right Front Mounting Bracket	2	10mm Hex Nuts
1	Driver/Left Center Mounting Bracket	6	8mm x 25mm Hex Bolts
1	Passenger/Right Center Mounting Bracket	6	8mm Lock Washers
1	Driver/Left Rear Mounting Bracket	12	8mm x 24mm x 2mm Flat Washers
1	Passenger/Right Rear Mounting Bracket	6	8mm Hex Nuts
3	Driver/Left Support Brackets	12	6mm T-Bolts
3	Passenger/Right Support Brackets	6	6mm x 20mm Button Head Bolts
2	10-1.5mm x 35mm Button Head Bolt Plates (Center Bracket)	12	6mm Lock Washers
2	12-1.75mm x 40mm Narrow Bolt Plate (for rear bracket-5/8" wide)	24	6mm x 22mm OD x 2.0mm Flat Washers
2	12-1.75mm x 35mm Wide Bolt Plate (for front bracket-13/16" wide)	6	6mm Nylon Lock Nuts
4	12mm Lock Washers	12	6mm Hex Nuts
4	12mm x 32mm x 3mm Flat Washers		

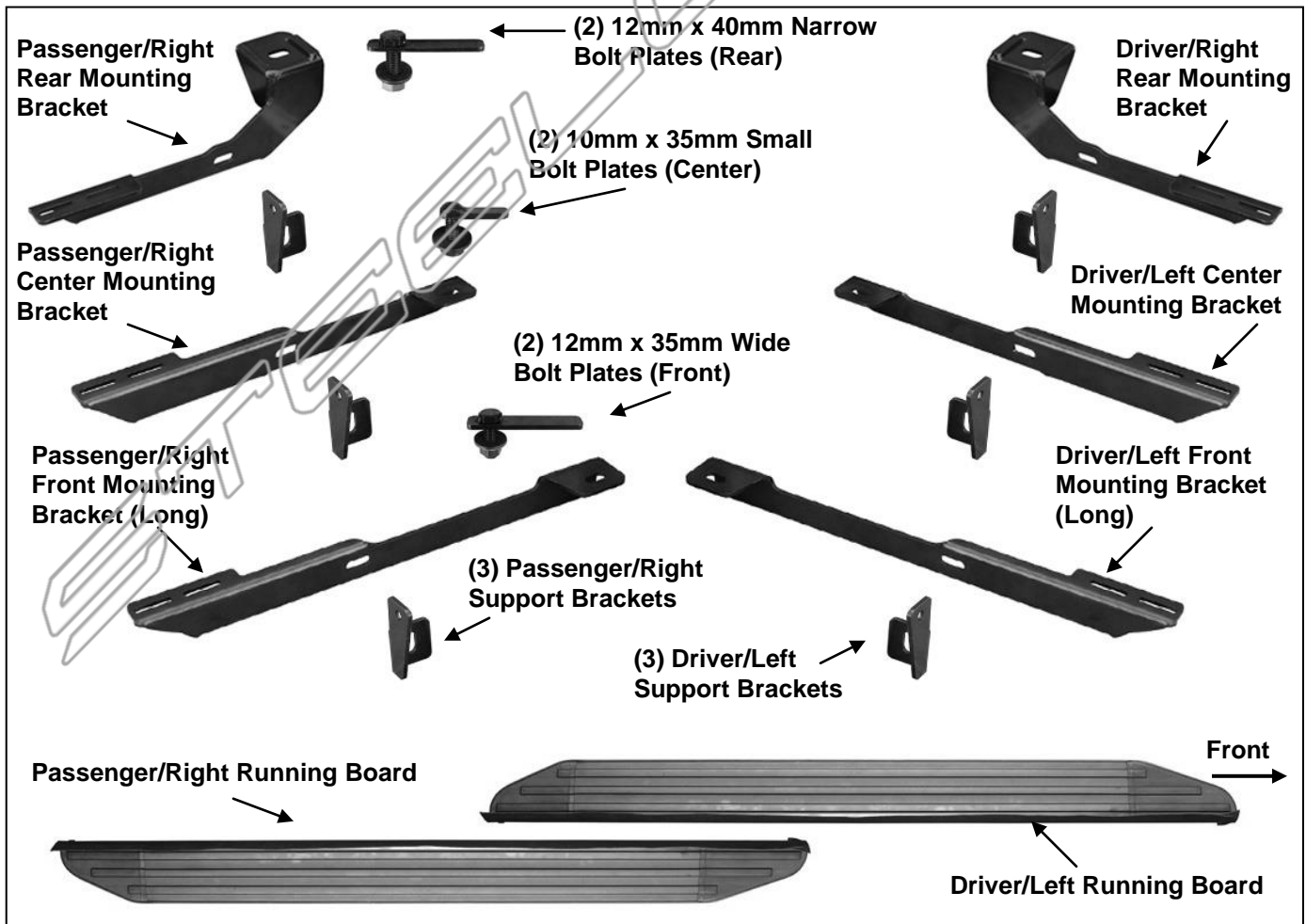

**ALUMINUM VIEWPOINT RUNNING BOARDS
2009-13 DODGE JOURNEY**

PROCEDURE:

- 1. REMOVE CONTENTS FROM BOX. VERIFY ALL PARTS ARE PRESENT. READ INSTRUCTIONS CAREFULLY BEFORE STARTING INSTALLATION. DRILLING IS REQUIRED. ASSISTANCE IS RECOMMENDED.**
2. Starting toward the front of the driver/left side of the vehicle, locate the factory oval hole in the bottom of the inner frame channel, **(Figure 12)**. Insert (1) 12mm x 35mm Wide Bolt Plate into the factory hole, **(Figures 2A & 2B)**. Select the driver side Front Bracket. Attach the Bracket to the Bolt Plate with (1) 12mm Flat Washer, (1) 12mm Lock Washer and (1) 12mm Hex Nut, **(Figure 3)**. Do not tighten hardware at this time.
3. Select (1) driver side Support Bracket, **(Figure 4A)**. Bolt the Support Bracket to the front of the Mounting Bracket with (1) 8mm x 25mm Hex Bolt, (2) 8mm Flat Washers, (1) 8mm Lock Washer and (1) 8mm Hex Nut, **(Figure 4B)**. Snug but do not tighten hardware at this time.
4. Move along the side to the center mounting location directly below where the front and rear doors meet. Locate the square hole in the bottom of the frame channel, **(Figure 5)**. Insert (1) 10mm Button Head Bolt Plate into the factory hole, **(Figures 6A & 6B)**. Attach the Center Mounting Bracket to the Bolt Plate with (1) 10mm Flat Washer, (1) 10mm Lock Washer and (1) 10mm Hex Nut, **(Figure 7)**. Snug but do not tighten hardware at this time.
5. Select (1) driver side Support Bracket, **(Figure 4A)**. Bolt the Support Bracket to the front of the Mounting Bracket with (1) 8mm x 25mm Hex Bolt, (2) 8mm Flat Washers, (1) 8mm Lock Washer and (1) 8mm Hex Nut, **(Figure 8)**. Snug but do not tighten hardware at this time.
6. Continue along the side of the vehicle toward the rear tire. Locate the factory oval hole in the floor panel, **(Figure 9)**. Insert (1) 12mm x 40mm Narrow Bolt Plate into the hole, **(Figures 10A & 10B)**. Rotate the Bolt Plate 90-degrees or until it stops so that the plate is across, not inline with the oval hole.
7. Attach the driver side Rear Mounting Bracket to the Bolt Plate with (1) 12mm Flat Washer, (1) 12mm Lock Washer and (1) 12mm Hex Nut, **(Figure 11)**. Snug but do not tighten at this time.
8. Repeat **Steps 3 & 5** to bolt the Support Bracket to the front of the Mounting Bracket, **(Figure 11)**.
9. Carefully unwrap and select the driver side Running Board. Insert (6) 6mm T-Bolts into the slots in the end of the channels, (3 T-Bolts per slot), on the bottom of the Running Board, **(Figure 12)**. Hold the Running Board up in the approximate position and slide the T-Bolts down the slots to line up with the Brackets. Tilt the Running Board up at a slight angle to clear the slots in the Brackets. Secure the Running Board to the Brackets with (6) 6mm Flat Washers, (6) 6mm Lock Washers and (6) 6mm Hex Nuts, **(Figure 13)**. **NOTE:** The Running Board is designed to fit close to the vehicle. It may be necessary to loosen and tilt the Brackets downward to insert the Running Board. Do not fully tighten hardware at this time.
10. Level and adjust the Running Board and tighten all Mounting Bracket to vehicle hardware. Line up the Support Brackets with the back of the pinch weld. Use clamps to temporarily attach the Support Brackets to the pinch weld, **(Figures 14 & 15)**. Align the Running Board and mark the location of the (3) Support Brackets onto the back of the pinch weld, **(Figures 4B, 8 & 13)**. Once all (3) locations are marked, remove the Running Board. Loosen the Brackets and move them out of the way. **VERY IMPORTANT:** Do not drill too close to the edge of the pinch weld.
11. Drill a 1/4" hole through the pinch weld at the front Bracket location. Move the front Bracket and Support Bracket back into position. Attach the Support Bracket to the pinch weld with (1) 6mm x 20mm Button Head Bolt, (2) 6mm Flat Washers and (1) 6mm Nylon Lock Nuts, **(Figure 16)**. Repeat this Step to install the Center and Rear Support Brackets.
12. Reinstall the Running Board, align, adjust as necessary and tighten all hardware.
13. Repeat **Steps 2 – 12** for passenger side Running Board installation.
14. Do periodic inspections to the installation to make sure that all hardware is secure and tight.

To protect your investment, wax this product after installing. Regular waxing is recommended to add a protective layer over the finish. Do not use any type of polish or wax that may contain abrasives that could damage the finish.

For stainless steel: Aluminum polish may be used to polish small scratches and scuffs on the finish. Mild soap may be used also to clean the Running Board.

For gloss black finishes: Mild soap may be used to clean Running Board.

Driver Side Installation Pictured

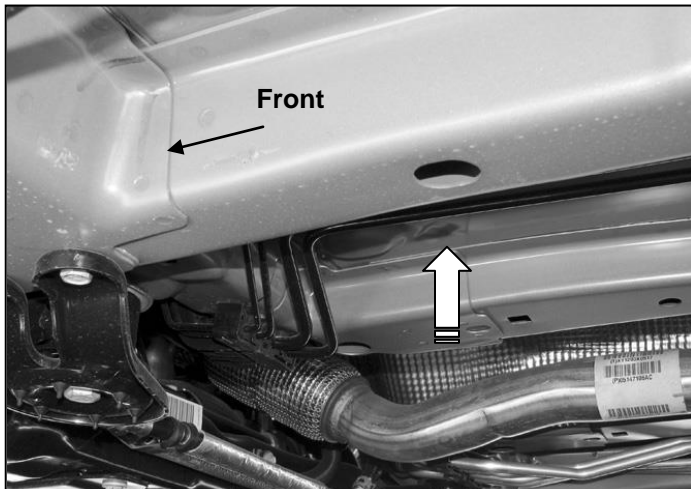

(Fig 1) Driver/left front mounting location pictured

12mm Flat Washer
12mm Lock Washer
12mm Hex Nut

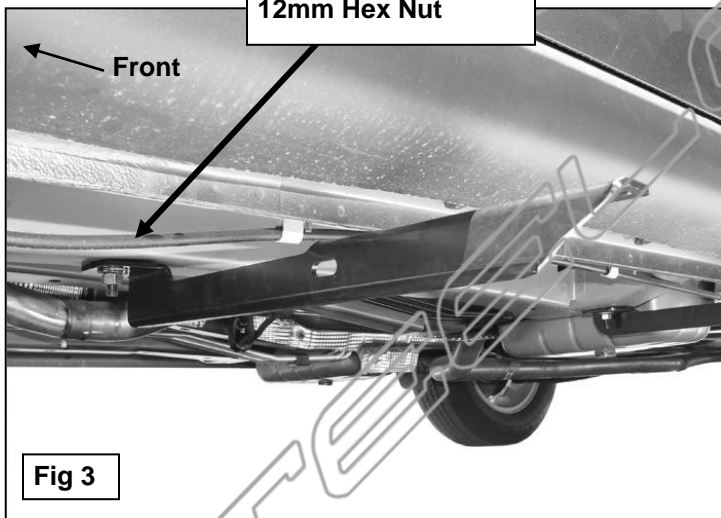
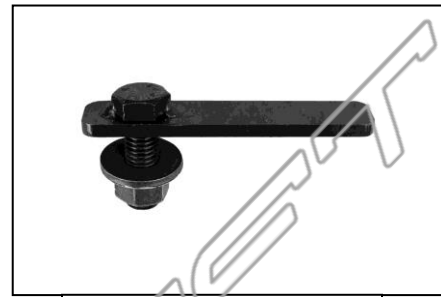

Fig 3



(Fig 2A) 12mm x 35mm
Wide Bolt Plate

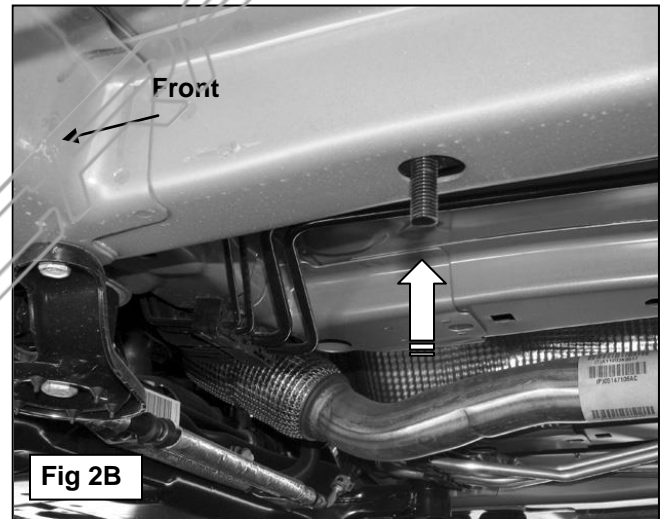

Fig 2B

Do not drill any mounting
locations until after all Brackets
have been installed and adjusted

8mm x 25mm Hex Bolt
8mm Lock Washer
(2) 8mm Flat Washers
8mm Hex Nut

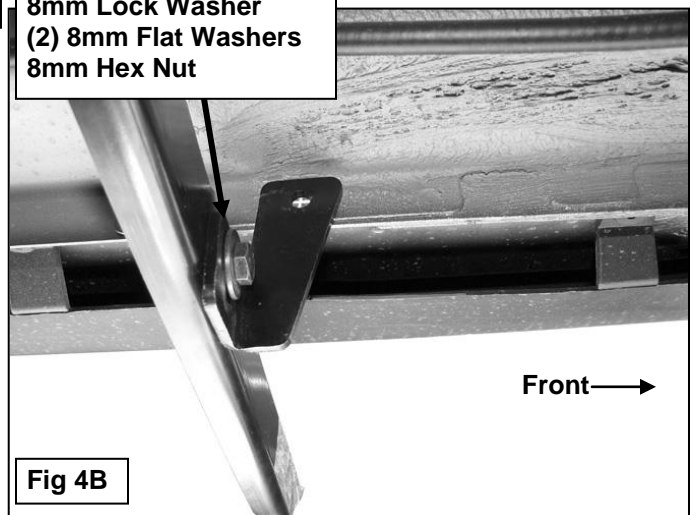
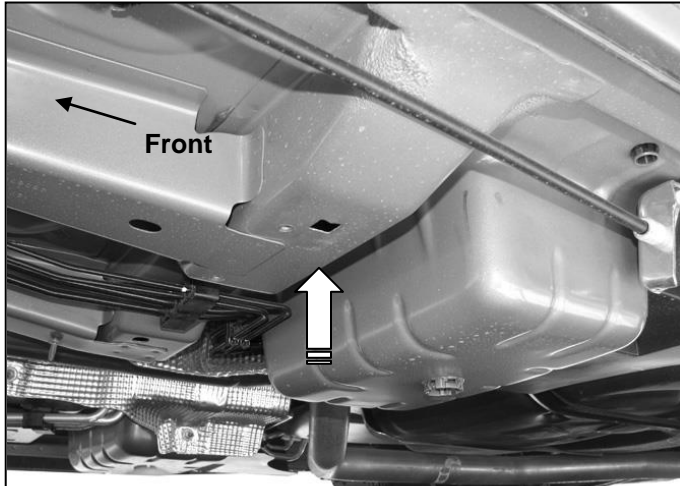

Fig 4B



(Fig 4A) Driver/left
Support Bracket (1 of 3)

Driver Side Installation Pictured



(Fig 5) Driver/left center mounting location pictured

10mm Flat Washer
10mm Lock Washer
10mm Hex Nut

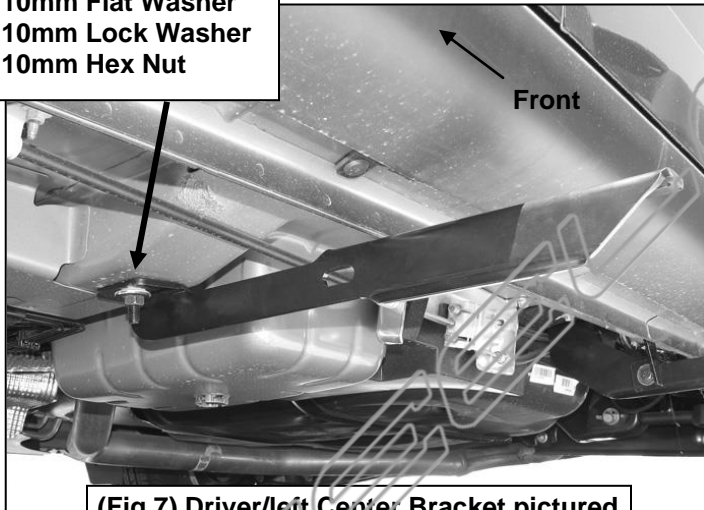

(Fig 7) Driver/left Center Bracket pictured

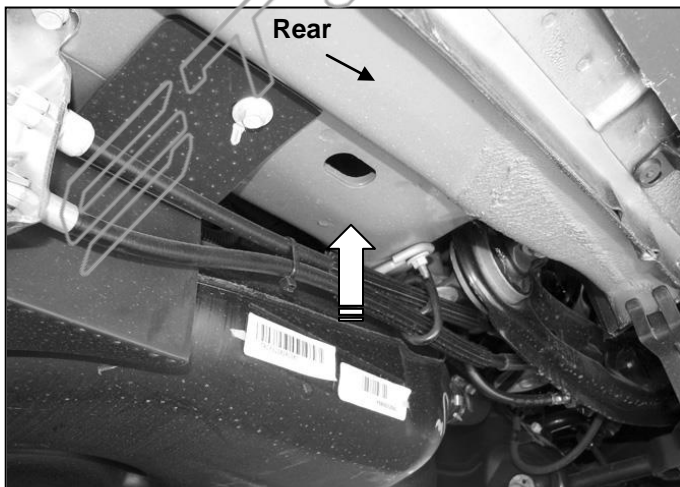

(Fig 9) Driver/left rear mounting location pictured



(Fig 6A) 10mm x 35mm Small
Button Head Bolt Plate

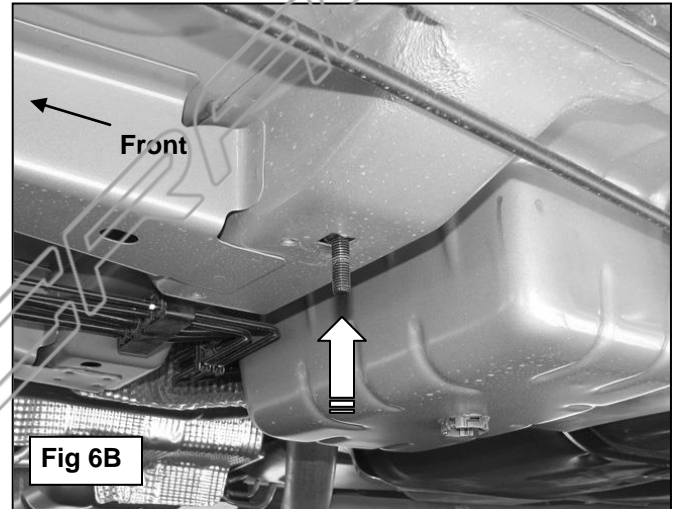
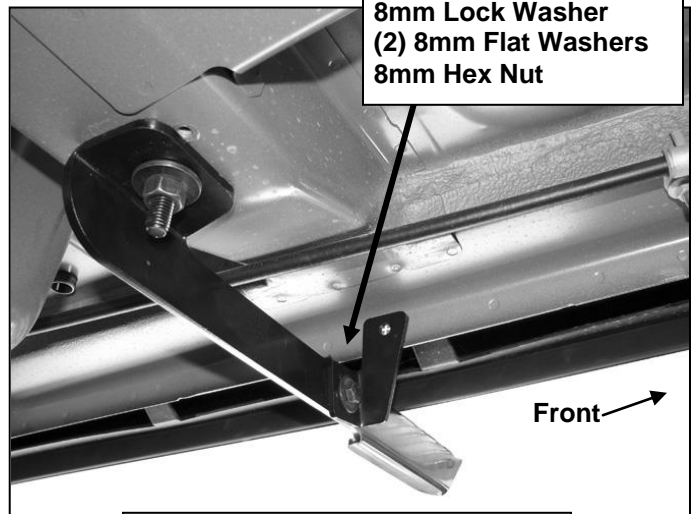

Fig 6B

8mm x 25mm Hex Bolt
8mm Lock Washer
(2) 8mm Flat Washers
8mm Hex Nut



(Fig 8) Driver/left Center Bracket
pictured with Support Bracket

Do not drill any mounting
locations until after all Brackets
have been installed and adjusted

Driver Side Installation Pictured



(Fig 10A) 12mm x 40mm
Narrow Bolt Plate

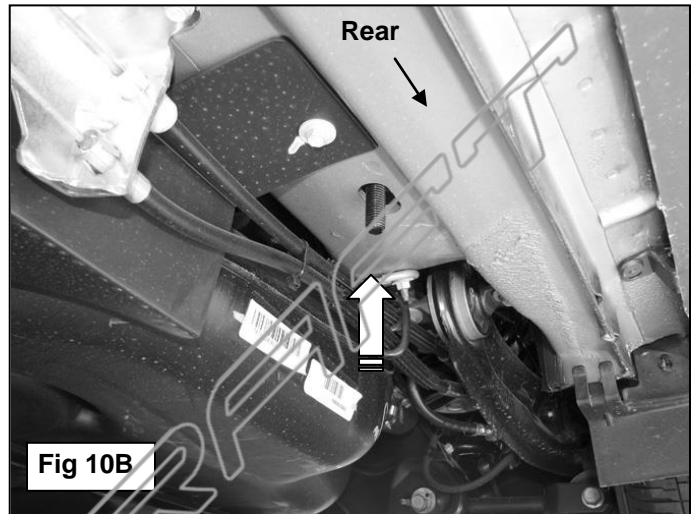
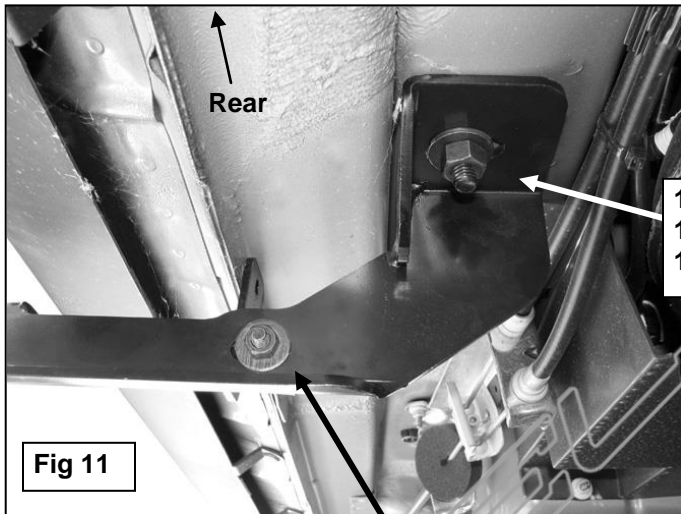

Fig 10B



Rear

12mm Flat Washer
12mm Lock Washer
12mm Hex Nut

Fig 11

8mm x 25mm Hex Bolt
8mm Lock Washer
(2) 8mm Flat Washers
8mm Hex Nut

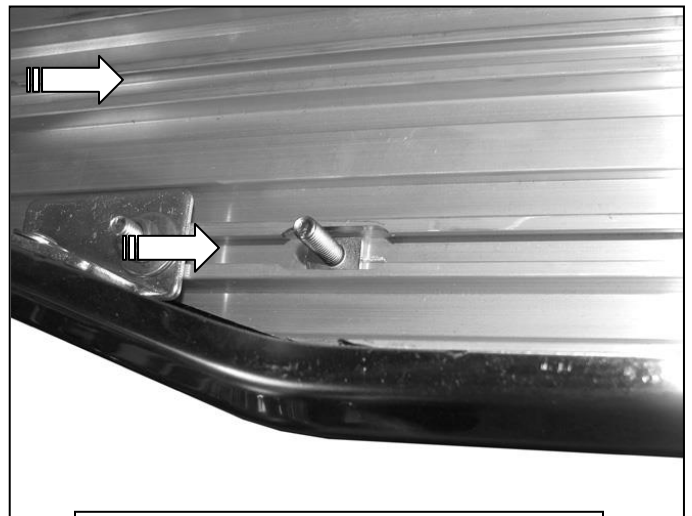

(Fig 12) Slide (3) T-Bolts into each track

Do not drill any mounting
locations until after all Brackets
have been installed and adjusted

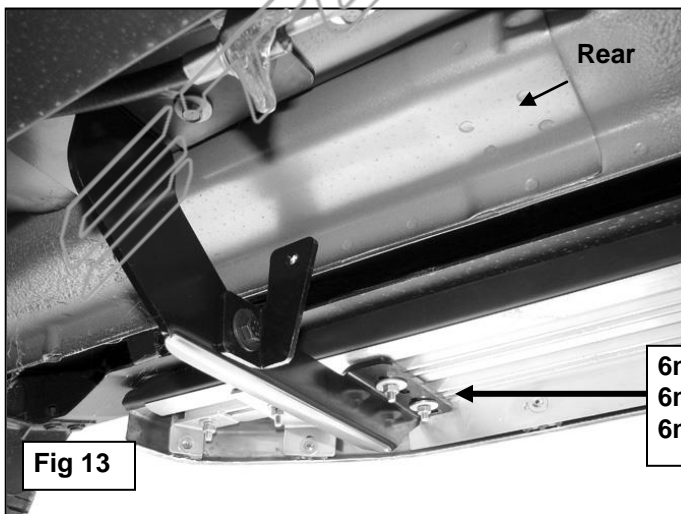

Rear

6mm Flat Washers
6mm Lock Washers
6mm Hex Nuts

Fig 13

**ALUMINUM VIEWPOINT RUNNING BOARDS
2009-13 DODGE JOURNEY**

Driver Side Installation Pictured

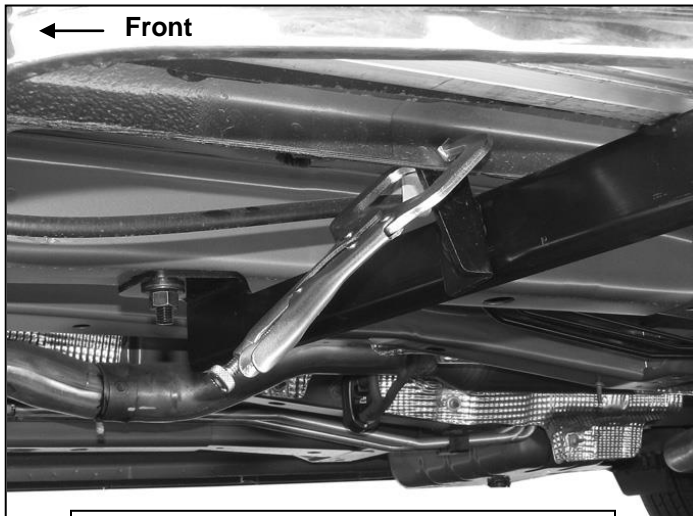

(Fig 14) Driver/left front Bracket pictured

**6mm x 20mm Button Head Bolt
(2) 6mm Flat Washers
6mm Nylon Lock Nut**

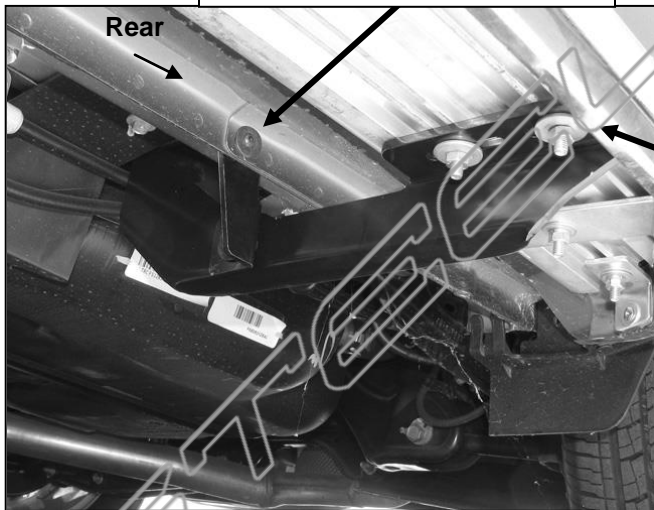

(Fig 16) Driver/left rear Bracket pictured

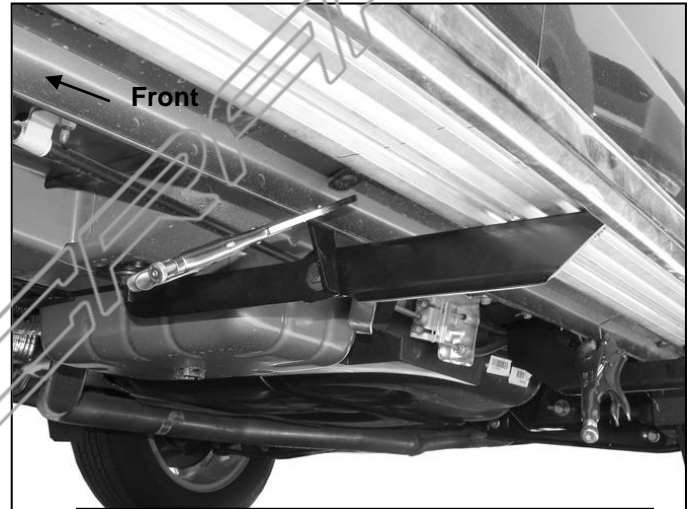

(Fig 15) Driver/left center Bracket pictured

**6mm Flat Washers
6mm Lock Washers
6mm Hex Nuts**

Use clamps or place stands under the Brackets to help hold the Brackets in proper position. Once aligned and adjusted, mark the locations of all (3) Support Brackets. Drill locations with a 1/4" drill bit. Do not drill too close to the edge of the pinch weld



**Installation
Complete**