

PARTS LIST:

1	Driver/Left side Running Board	8	10mm Plastic Retainers
1	Passenger/Right side Running Board	2	10-1.5mm x 25mm Hex Bolts
1	Driver/Left front Mounting Bracket	1	10-1.5mm x 35mm Hex Bolt (Threaded Insert Tool)
1	Passenger/Right front Mounting Bracket	14	10mm x 27mm x 3mm STD Flat Washers
1	Driver/Left front Support Bracket	1	10mm ID x 20mm OD x 2mm Flat Washer
1	Passenger/right front Support Bracket	12	10mm Serrated Flange Nuts
1	Driver/left center Mounting Bracket	1	10mm Hex Nut
1	Passenger/right center Mounting Bracket	1	10mm Insert Tool
1	Driver/Left rear Mounting Bracket	1	10-1.5mm Threaded Insert
1	Passenger/right rear Mounting Bracket	12	6mm T-Bolts
2	10mm x 35mm Bolt Plates	12	6mm x 22mm OD x 2mm Flat Washers
2	10mm x 50mm "T" Bolts	12	6mm Lock Washers
6	10mm Bent Threaded Rod Bolts	12	6mm Hex Nuts

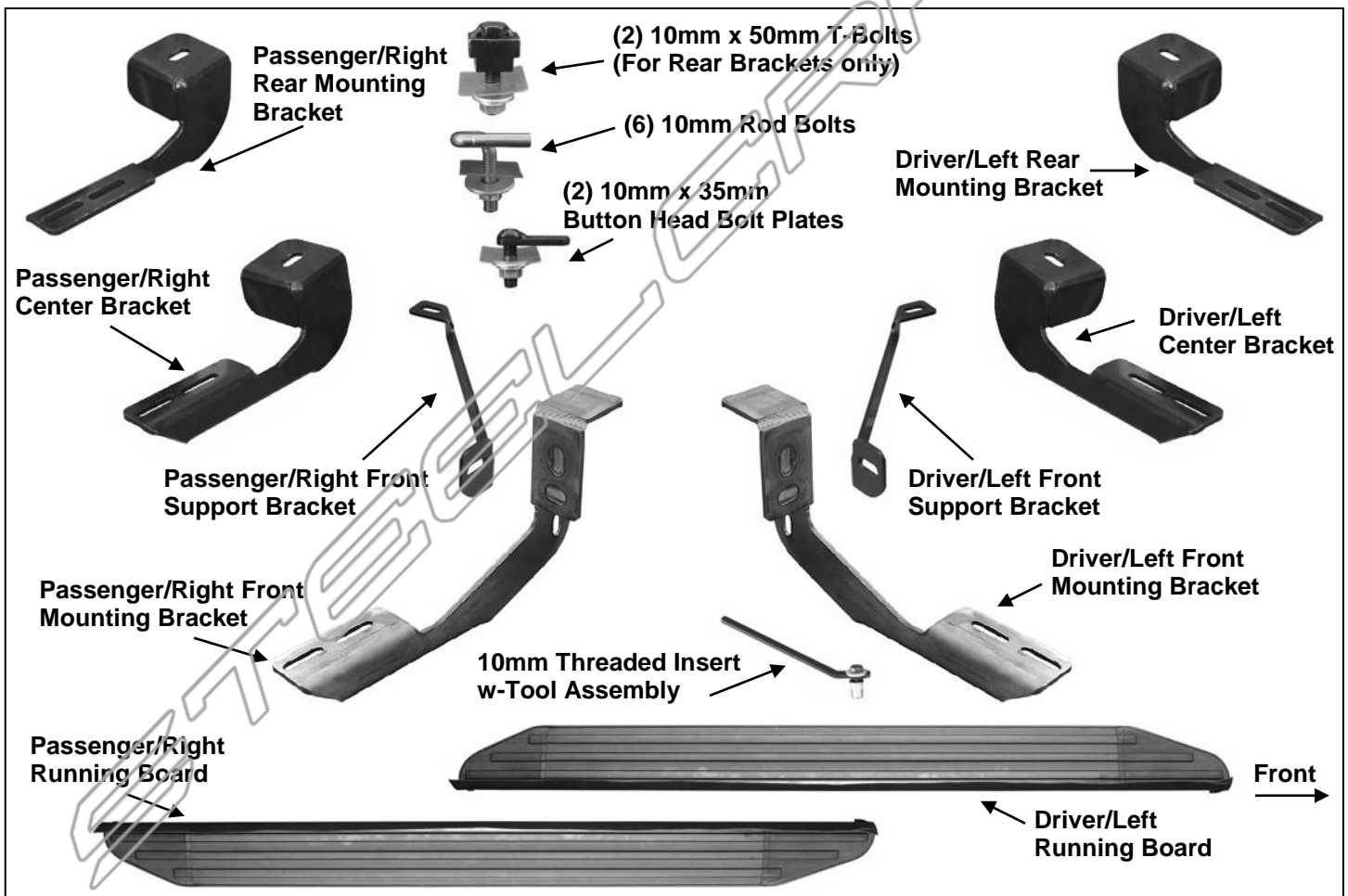

PROCEDURE:

1. REMOVE CONTENTS FROM BOX. VERIFY ALL PARTS ARE PRESENT. READ INSTRUCTIONS CAREFULLY BEFORE STARTING INSTALLATION. CUTTING IS REQUIRED. ASSISTANCE IS RECOMMENDED.
2. Start installation under the driver side front of the vehicle. Remove the plastic cover, (Figure 1). Pay close attention to the type and location of all factory hardware for reinstallation.
3. Locate the factory hole(s) in the inside wall of the floor panel, (Figure 2). NOTE: The mounting locations may be covered by sealant or undercoating. Use a small screwdriver to poke through

the sealant to uncover the hole. **IMPORTANT:** Brackets must sit flat against sheet metal. Scrape any excess sealant from body panel before installing any and all Brackets.

4. Select the correct driver side front bracket installation for your model year:

**2011-14 models with (2) factory holes in driver side-front location. Also use for passenger side front bracket installation, all model years:**

- a. Select (1) 10mm Rod Bolt and (1) 10mm Plastic Retainer, **(Figure 3)**. Partially thread the Retainer onto the Rod Bolt. Insert the Rod Bolt into the factory hole in the side panel, **(Figure 4)**. Thread the Retainer down until it is tight against the floor panel. The Retainer is designed to help hold the Rod Bolt in place during Bracket installation. Repeat this Step to install the second Rod Bolt in the remaining hole.
- b. Hang the driver side Front Bracket from the (2) Rod Bolts with (2) 10mm x 34mm Large Flat Washers and (2) 10mm Flange Nuts, **(Figure 5)**. Snug but do not tighten hardware at this time.

**2015-on with (1) factory hole in driver side-front location-applies to driver side front bracket install only:**

- a. Locate the single factory hole as previously described in Step 3, **(Figure 6)**. Select the 10mm Threaded Insert Tool, (1) 10mm Threaded Insert, (1) 10mm x 20mm Small Flat Washer, (1) 10mm Hex Nut and (1) 10mm x 35mm Hex Bolt. Assemble the tool as pictured in **Figure 7**.
  - b. Push the Threaded Insert assembly into the factory hole. Hold tool handle and assembly up tight against the inner body panel. Tighten the 10mm hex bolt until insert is fully expanded into hole, **(Figure 8)**. **NOTE:** Do not over tighten the Hex Bolt or damage to the insert, body panel or insert pull out may occur.
  - c. Once Metal Insert is fully compressed, remove the bolt and tool from the Metal Insert.
  - d. Line up the top slot in the Driver Side Front Bracket with the Threaded Insert. Attach the Bracket to the Insert with (1) 10mm x 35mm Hex Bolt, (1) 10mm x 27mm STD Flat Washer and (1) 10mm Flange Nut, **(Figure 9)**. Do not tighten hardware at this time.
5. Next, remove the plastic plug from the bottom of the frame channel, **(Figure 10)**. Select (1) 10mm button head Bolt Plate and (1) Plastic Retainer, **(Figure 11)**. Partially thread the Retainer onto the Bolt Plate. Insert the Bolt Plate into the hole in the bottom of the frame channel, **(Figure 12)**. Thread the Retainer down tight against the sheet metal to hold the Bolt Plate in place.
6. Select the driver side front Support Bracket. Secure the Bracket to the back of the front Mounting Bracket with (1) 10mm x 25mm Hex Bolt, (2) 10mm x 27mm STD Flat Washers and (1) 10mm Flange Nut, **(Figure 13)**. Leave hardware loose at this time. Attach the inner end of the Support Bracket to the Bolt Plate with (1) 10mm x 27mm STD Flat Washer and (1) 10mm Flange Nut, **(Figure 14)**. Snug but do not fully tighten hardware at this time.
7. Move toward the center of the vehicle. Locate the factory hole in the bottom of the outer frame channel, **(Figure 15)**. **NOTE:** Hole may be covered with sealant as described in **Step 3**. Select (1) 10mm Rod Bolt and (1) 10mm Plastic Retainer, **(Figure 16)**. Insert Rod Bolt into factory hole and tighten Retainer, **(Figure 17)**.
8. Select the driver side Center Bracket, **(Figure 18)**. **IMPORTANT: the Center and Rear Brackets are similar, use Figure 18 to properly identify the Center and Rear Brackets.** Attach the Center Bracket to the Rod Bolt with (1) 10mm x 27mm STD Flat Washer and (1) 10mm Flange Nut, **(Figure 19)**. Snug but do not fully tighten hardware at this time.
9. Move to the rear mounting location and locate the large oval hole in the floor panel. Select (1) 10mm T-Bolt and (1) 10mm Plastic Retainer, **(Figure 20)**. Partially thread the Retainer onto the T-Bolt. Insert the T-Bolt into the oval hole in the floor panel and rotate Bolt 90-degrees so

that the Block is across the oval hole, **(Figure 21)**. Thread the Retainer down until it is tight against the floor panel, **(Figure 22)**.

10. Select the driver side Rear Mounting Bracket, **(Figures 18 & 23)**. Attach the Bracket to the T-Bolt with (1) 10mm x 27mm STD Flat Washer and (1) 10mm Flange Nut, **(Figure 23)**. Snug but do not fully tighten hardware at this time.
11. Carefully unwrap the Running Boards and select the driver side. Insert (6) 6mm T-Bolts into the slots in the end of the channels, (3 T-Bolts per channel), on the bottom of the Running Board, **(Figure 24)**. Hold the Running Board up in approximate position and slide the T-Bolts down to line up with the Mounting Brackets. Tilt the Board up at a slight angle and push back against the vehicle until the T-Bolts fit into the slots on the Brackets. Attach the Board to the Brackets with (6) 6mm Flat Washers, (6) 6mm Lock Washers and (6) 6mm Hex Nuts, **(Figure 25)**. Do not tighten hardware at this time. **NOTE:** the Running Board is designed to fit close to the vehicle. It may be necessary to temporarily loosen the Bracket hardware and tilt the Brackets downward to insert the Running Board.
12. Level and adjust the Running Board as desired and tighten all hardware **except** the hardware securing the front Support Bracket, **(Figure 13)**. Once all other hardware has been tightened, temporarily remove the front Support Bracket. Hold the plastic cover removed in **Step 2**, up in position. Trace the location of the front Bracket onto the cover, **(Figure 26)**. Carefully cut the plastic cover to clear the Bracket, **(Figure 27)**. **IMPORTANT:** Cut as little as possible from the cover. Reinstall the plastic cover with factory hardware. Reinstall the Support Bracket over the plastic cover as described in **Step 6**. Tighten all hardware.
13. Repeat **Steps 2—12** for passenger side Running Board installation. **NOTE:** Follow **2011-14** driver side front bracket installation instructions for passenger side front bracket installation.
14. Do periodic inspections to the installation to make sure that all hardware is secure and tight.

**To protect your investment**, wax this product after installing. Regular waxing is recommended to add a protective layer over the finish. Do not use any type of polish or wax that may contain abrasives that could damage the finish.

**For stainless steel:** Aluminum polish may be used to polish small scratches and scuffs on the finish. Mild soap may be used also to clean the Running Board.

#### Driver/Left Side Installation Pictured

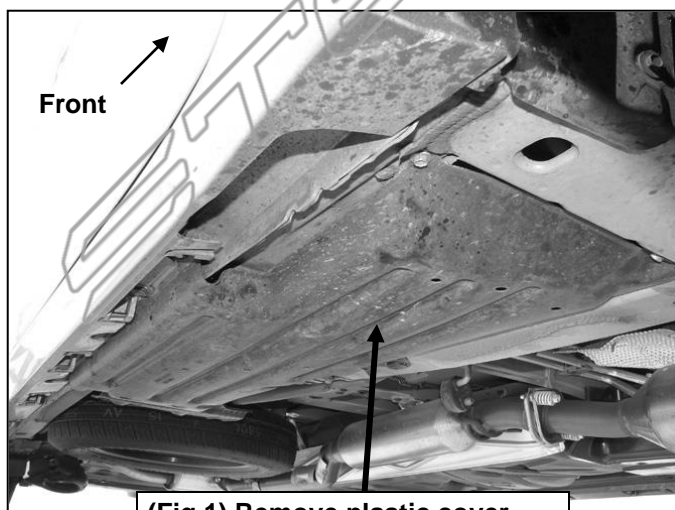

**(Fig 1)** Remove plastic cover.  
**NOTE:** Passenger side pictured

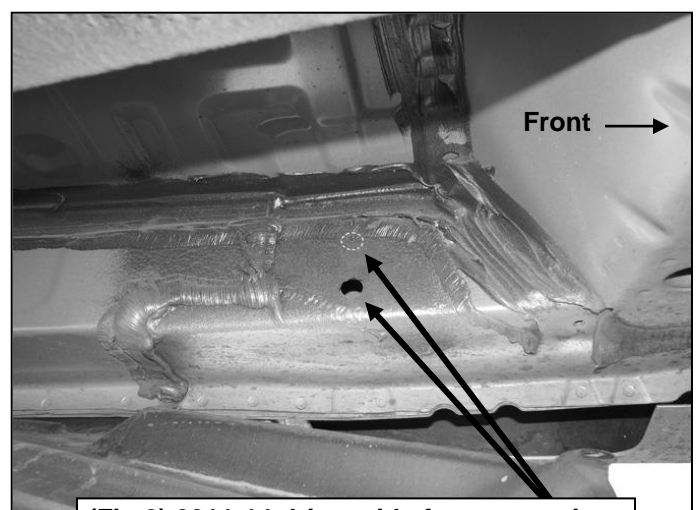

**(Fig 2)** 2011-14 driver side front mounting location-remove sealant as necessary

Driver/Left Side Installation Pictured

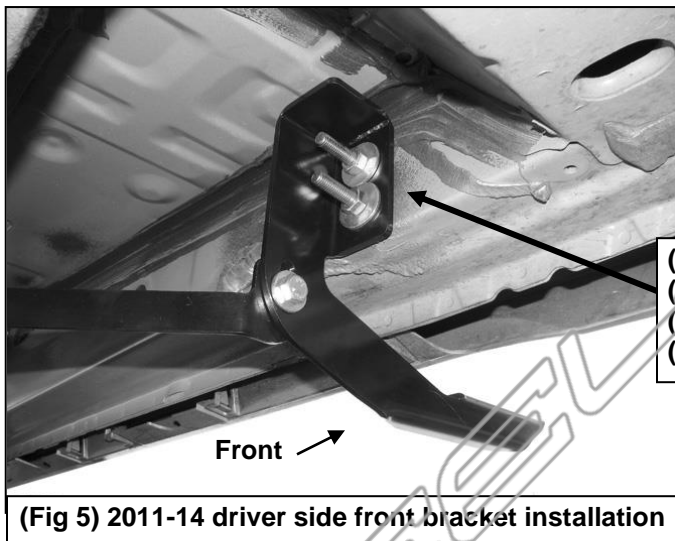
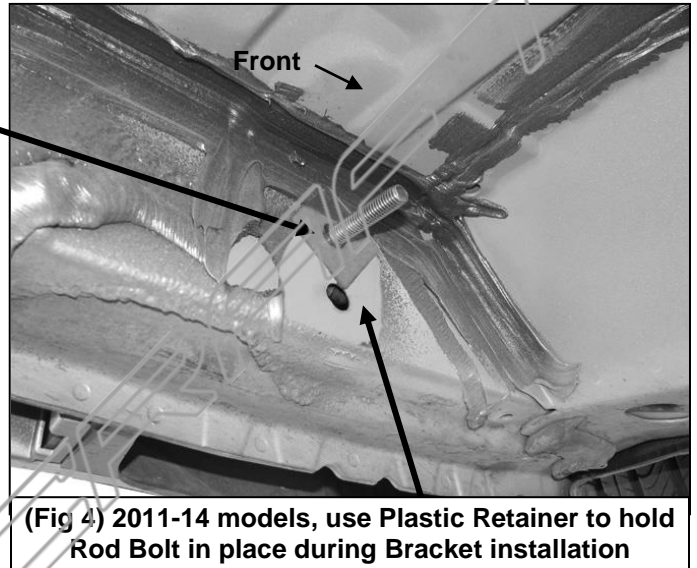
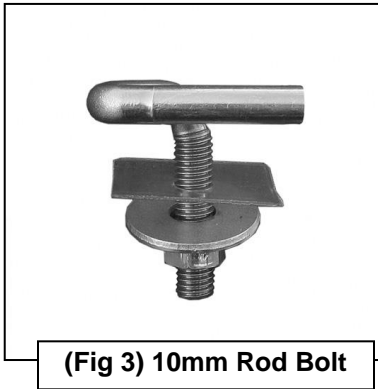

- (2) 10mm Rod Bolts
- (2) 10mm Plastic Retainers
- (2) 10mm STD Flat Washers
- (2) 10mm Flange Nuts

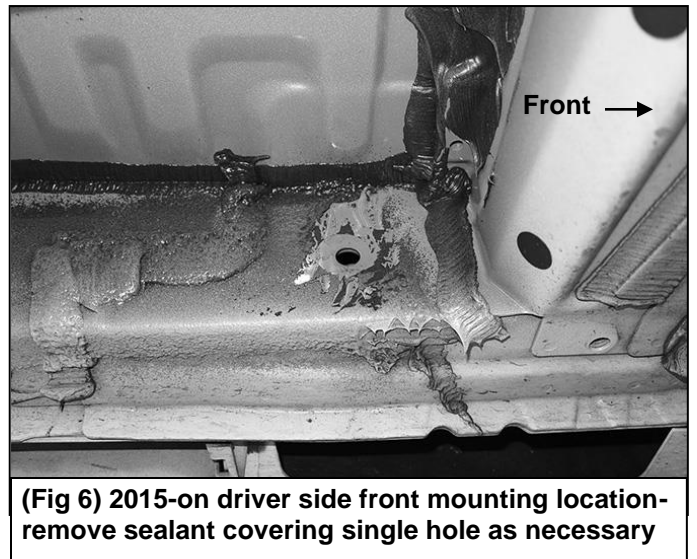
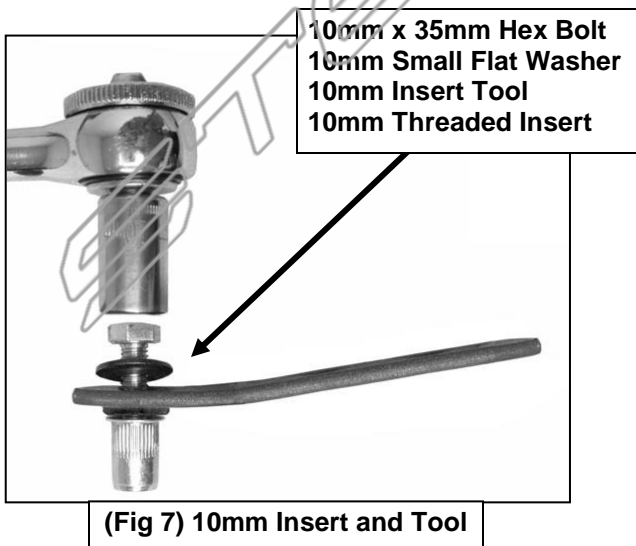

Driver Side Installation Pictured

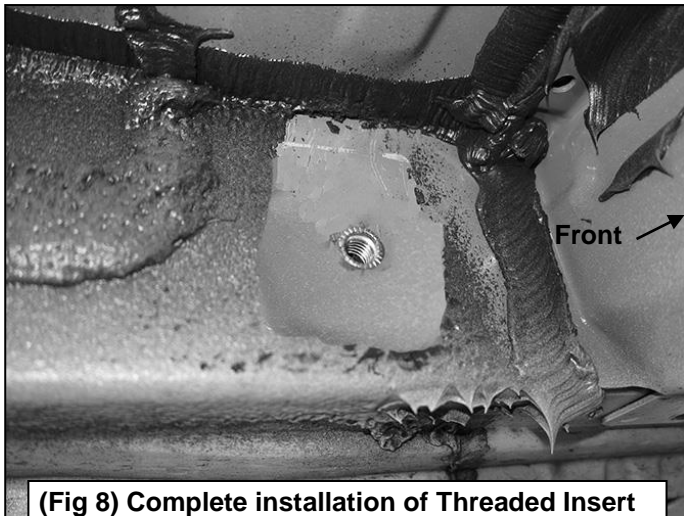

(Fig 8) Complete installation of Threaded Insert required on driver side 2015-on models only

Hold handle and push insert into factory hole. Gently tap into hole if necessary. Hold insert in place by firmly grasping the handle on the tool. Turn the hex bolt (tighten) with wrench to expand insert in part. Once Metal Insert is fully compressed, remove the bolt and tooling from Metal Insert. **WARNING:** Do not overtighten or damage to the part or insert may result.

10mm x 35mm Hex Bolt  
10mm Lock Washer  
10mm STD Flat Washer

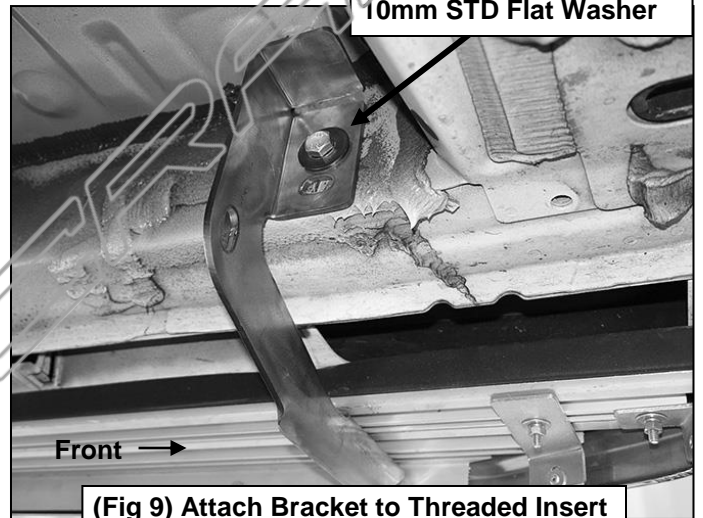

(Fig 9) Attach Bracket to Threaded Insert

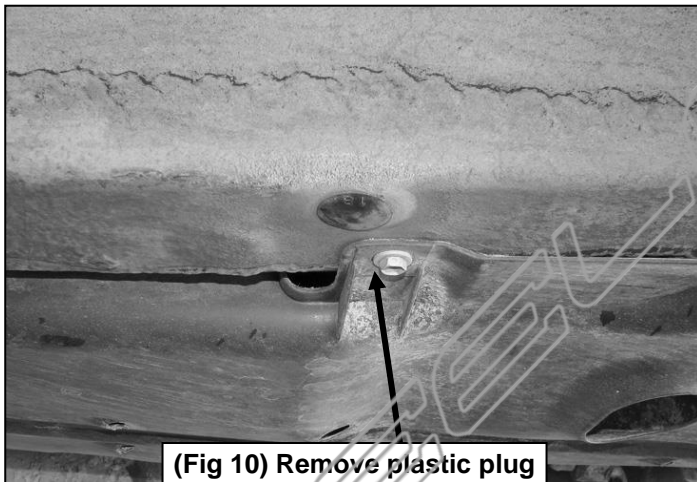

(Fig 10) Remove plastic plug on bottom of frame channel

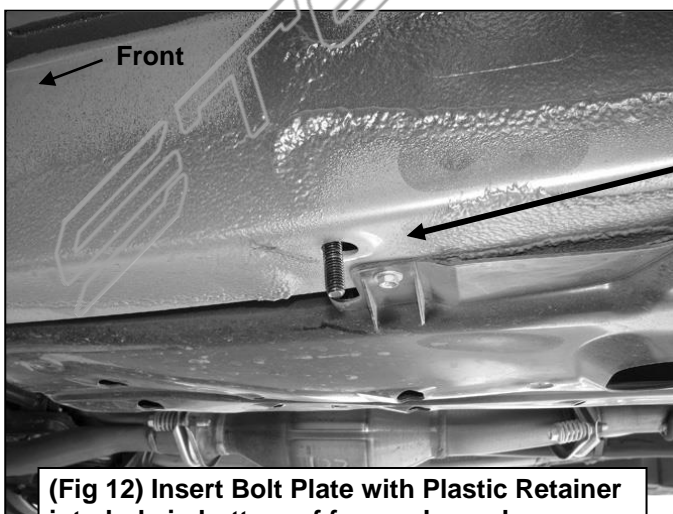

(Fig 12) Insert Bolt Plate with Plastic Retainer into hole in bottom of frame channel



(Fig 11) 10mm x 35mm Bolt Plate

Driver Side Installation Pictured

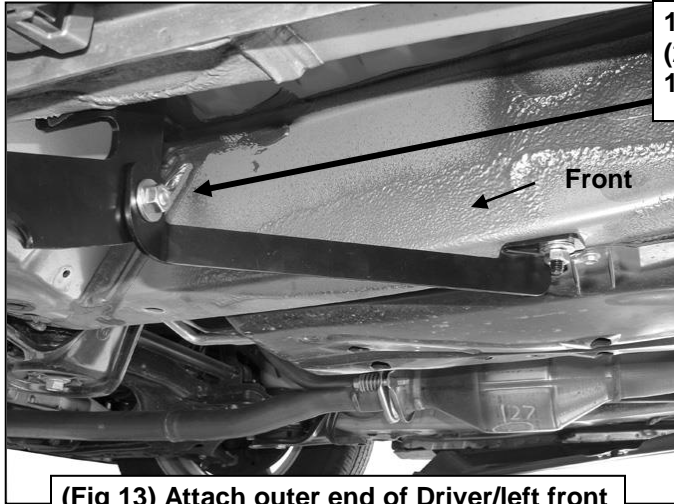

10mm Hex Bolt  
(2) 10mm STD Flat Washers  
10mm Flange Nut

(Fig 13) Attach outer end of Driver/left front Support Bracket to back of Front Bracket

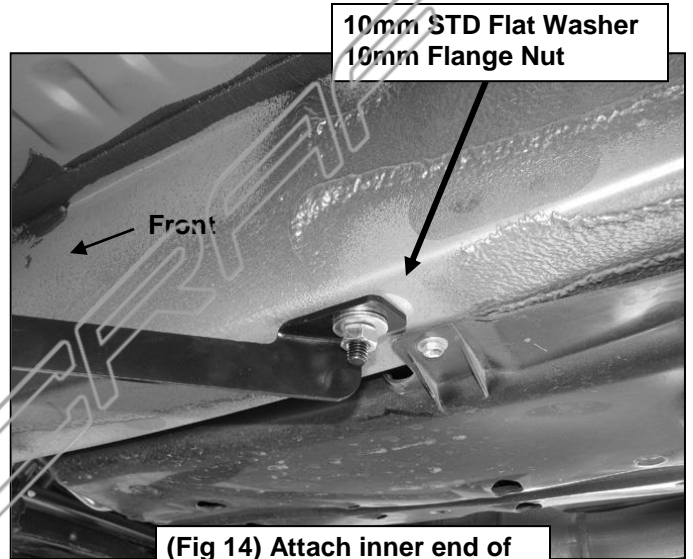

10mm STD Flat Washer  
10mm Flange Nut

(Fig 14) Attach inner end of Support Bracket to Bolt Plate

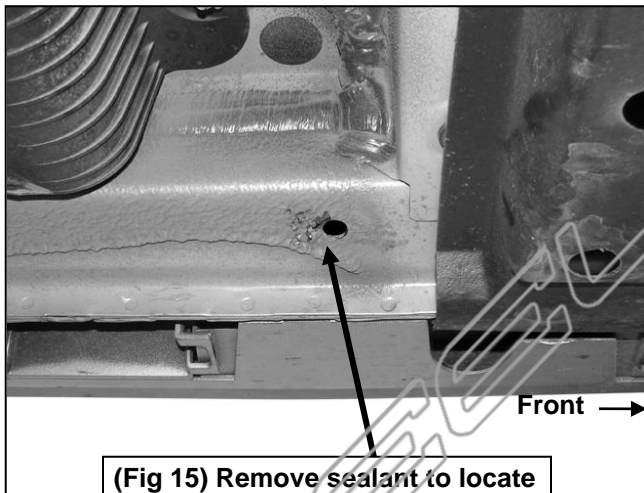

(Fig 15) Remove sealant to locate factory hole for center Bracket

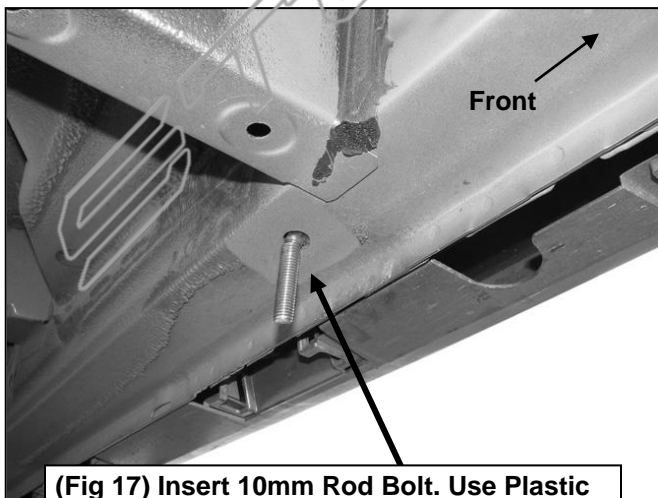

(Fig 17) Insert 10mm Rod Bolt. Use Plastic Retainer to hold Rod Bolt in position

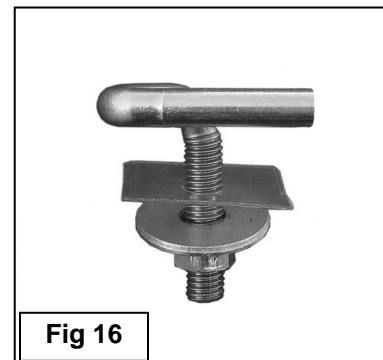
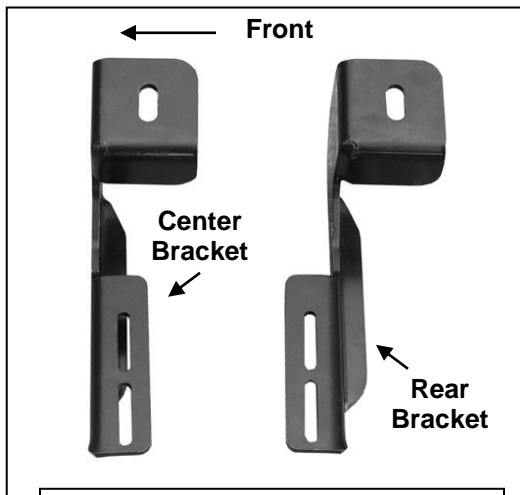
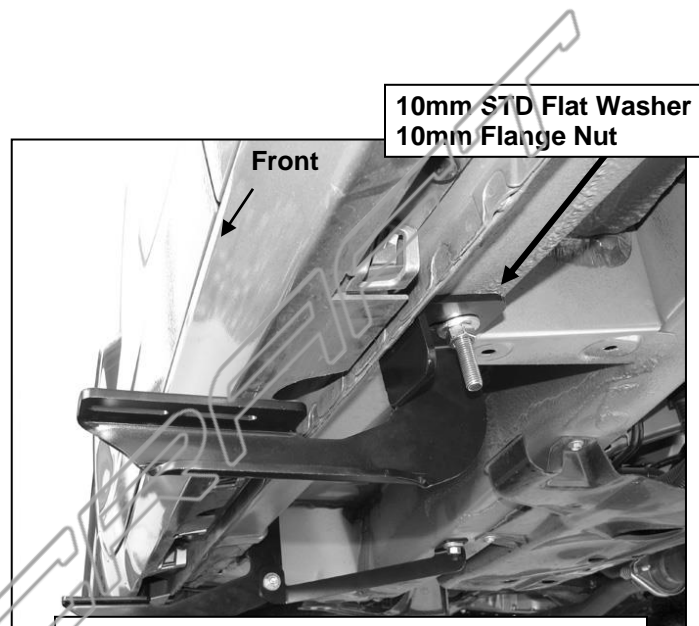

Fig 16

Driver Side Installation Pictured



(Fig 18) IMPORTANT: Driver side Center Bracket (cradle to rear) and Rear Bracket (cradle to front)



(Fig 19) Driver side Center Bracket pictured

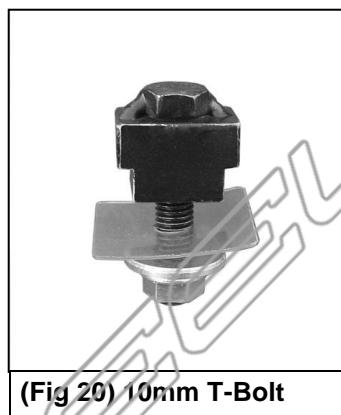

(Fig 20) 10mm T-Bolt

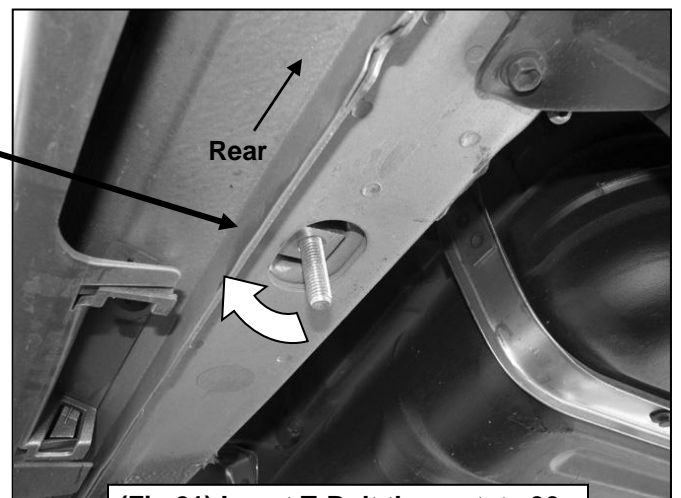

(Fig 21) Insert T-Bolt then rotate 90-degrees to go across oval hole

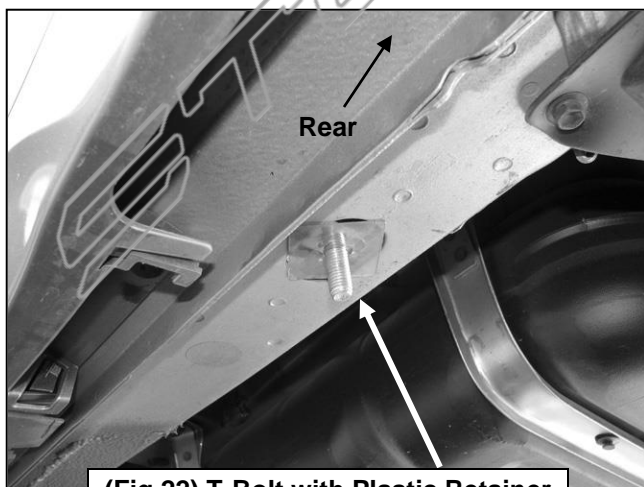

(Fig 22) T-Bolt with Plastic Retainer

Driver Side Installation Pictured

