

INSTALLATION INSTRUCTIONS
VIEWPOINT RUNNING BOARDS
16-17 HONDA PILOT

STEELCRAFT

PARTS LIST:

1	Driver side running board	12	8mm Lock Washer
1	Passenger side running board	12	8mm x 24mm x 2mm Flat Washers
2	Front Mounting Brackets (use for left or right)	12	6-1.0 x 20mm T-Bolts
2	Center Mounting Brackets (use for left or right)	12	6mm x 22mm OD x 2mm Flat Washer
2	Rear Mounting Brackets (use for left or right)	12	6mm Lock Washer
12	8-1.25mm x 25mm Hex Bolt	12	6-1.0mm Hex Nuts

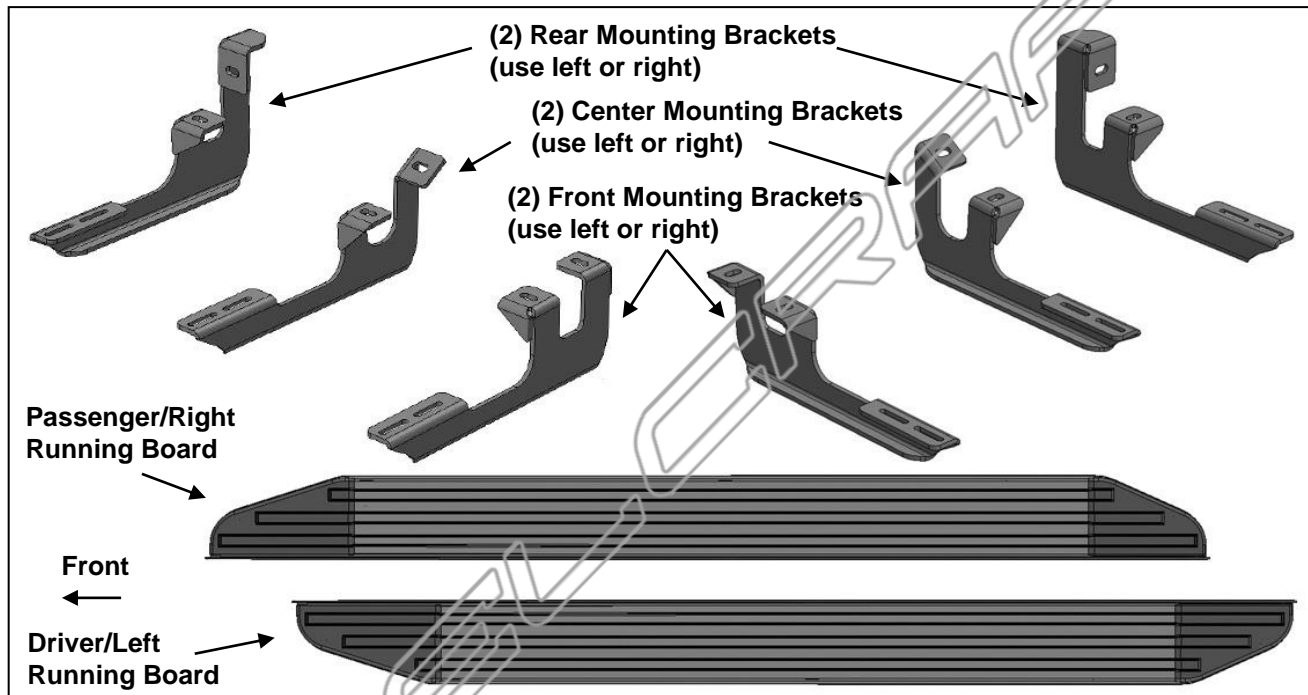

PROCEDURE:

PROCEDURE:

- 1. REMOVE CONTENTS FROM BOX. VERIFY ALL PARTS ARE PRESENT. READ INSTRUCTIONS CAREFULLY BEFORE STARTING INSTALLATION.**
- Starting on the driver/left side front of the vehicle, locate the two factory 8mm threaded holes located in the bottom of the floor panel, **(Figure 1)**. **NOTE:** Brackets install in the factory running board mounting locations. Threaded holes may be covered with insulation. Clean mounting locations as required for proper Bracket installation.
- Select (1) Front Mounting Bracket, **(Figure 2)**. **NOTE:** Brackets will fit left or right side. Attach the Bracket to the two threaded holes with (2) 8mm x 25mm Hex Bolts, (2) 8mm Lock Washers and (2) 8mm Flat Washers, **(Figure 3)**. Do not tighten hardware at this time.
- Move to the center of the vehicle. Locate the two threaded holes in the bottom of the floor panel and body support panel, **(Figure 4)**. Repeat **Steps 2 & 3** to attach (1) Center Bracket, **(Figures 5 & 6)**.
- Next, move to the driver/left rear of the vehicle. Locate the holes in the bottom and inner side of the floor panel, **(Figure 7)**. Repeat **Steps 2 & 3** to install (1) Rear Bracket, **(Figures 8 & 9)**.
- Select the driver/left side Running Board. Locate the openings cut at the end of the slots on the bottom of the Running Board, **(Figure 10)**. Insert (3) 6mm T-Bolts into each channel through the openings. Slide the T-Bolts into the approximate position in line with the (3) Brackets on the vehicle.

7. Carefully position the Driver/Left Running Board onto the (3) Mounting Brackets. Slide the T-Bolts into position and through the slots in the Brackets. Attach the Board to the Brackets with (6) 6mm Flat Washers, (6) 6mm Lock washers and (6) 6mm Hex Nuts, **(Figure 11)**.
NOTE: Temporarily loosen Brackets if necessary to fit Running Board between Brackets and vehicle. Do not tighten hardware at this time.
8. Level and adjust the Running Board and tighten all hardware.
9. Repeat **Steps 2—8** for the passenger/right Running Board installation.
10. Do periodic inspections to the installation to make sure that all hardware is secure and tight.

To protect your investment, wax this product after installing. Regular waxing is recommended to add a protective layer over the finish. Do not use any type of polish or wax that may contain abrasives that could damage the finish. **For stainless steel:** Aluminum polish may be used to polish small scratches and scuffs on the finish. Mild soap may be used also to clean the Running Board.

Driver Side Installation Pictured

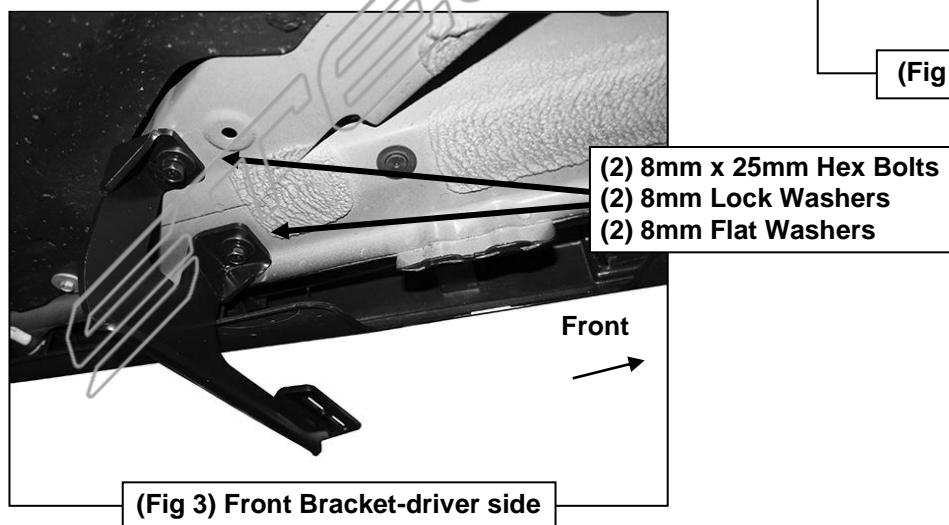
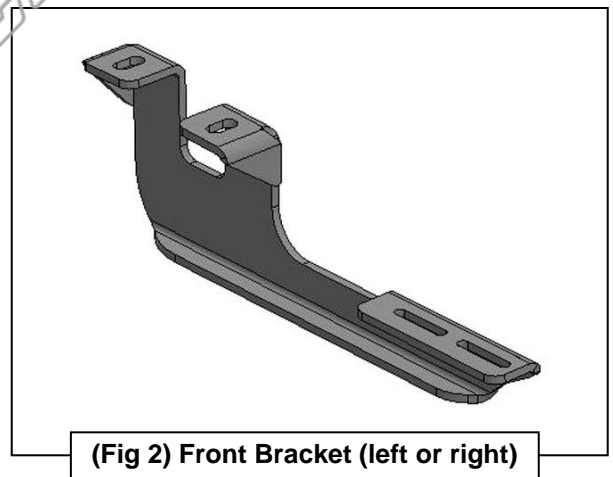
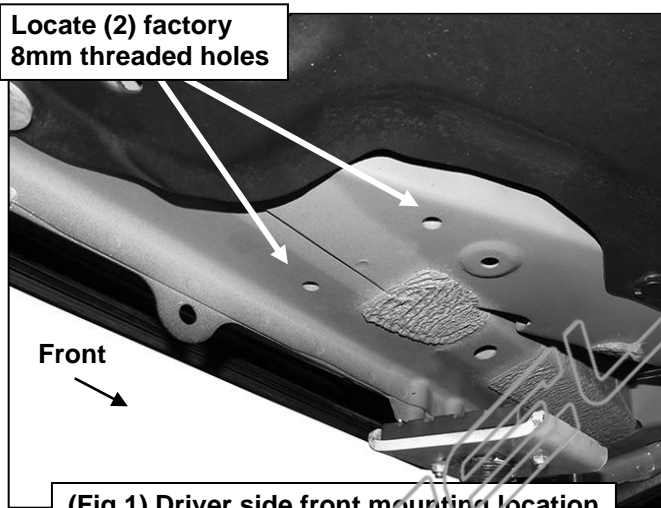

Driver Side Installation Pictured

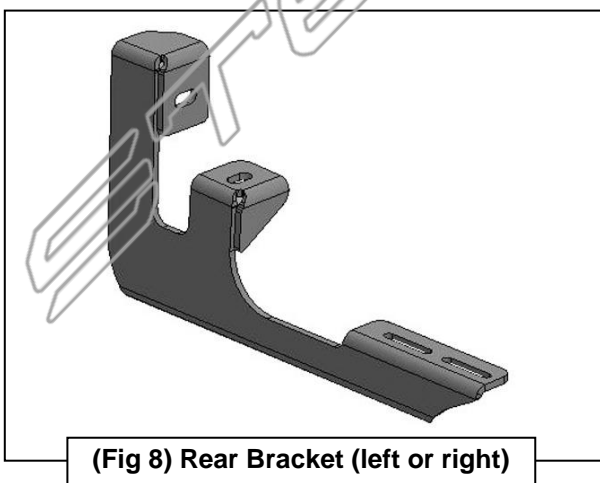
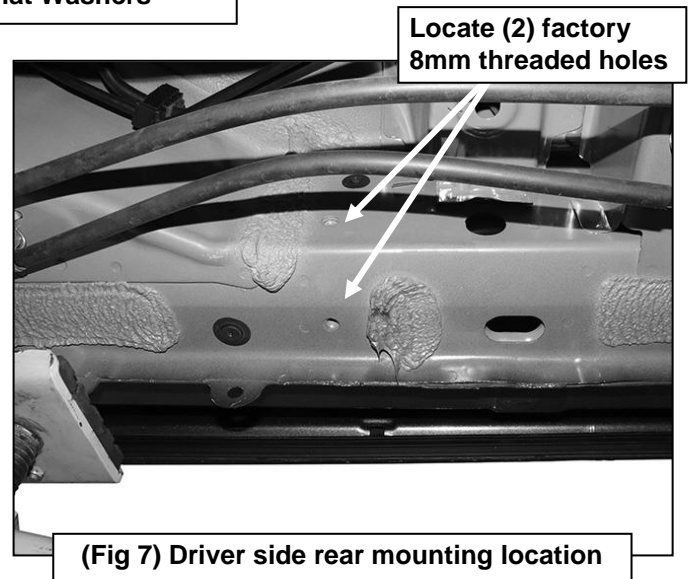
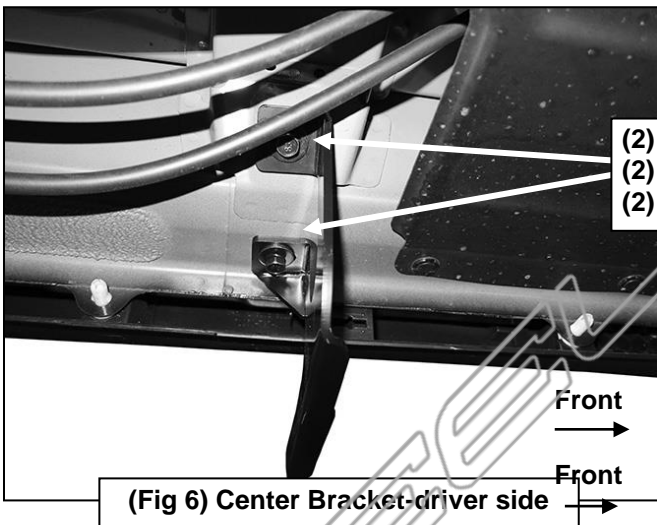
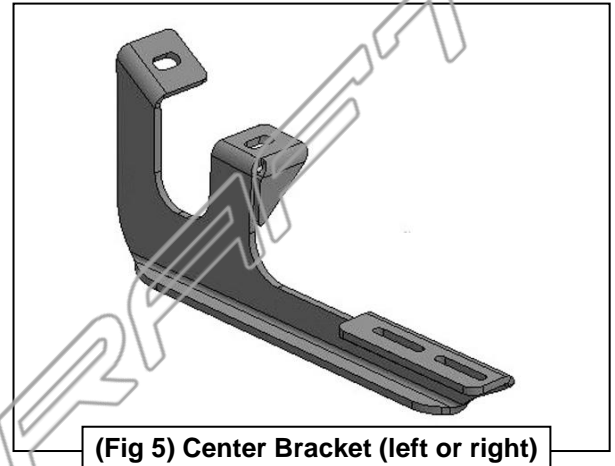
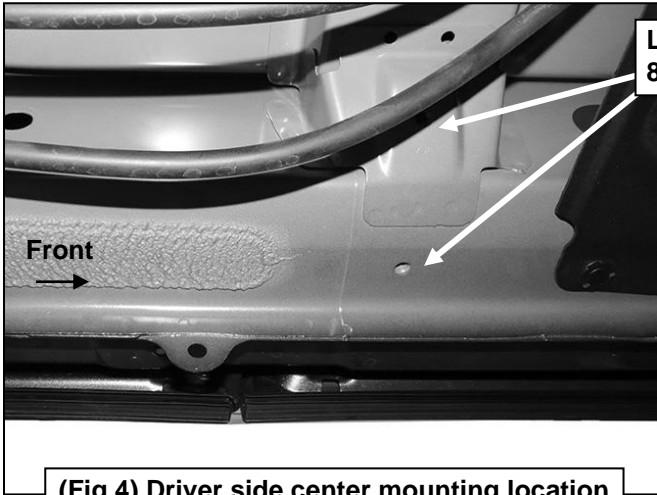

Driver Side Installation Pictured

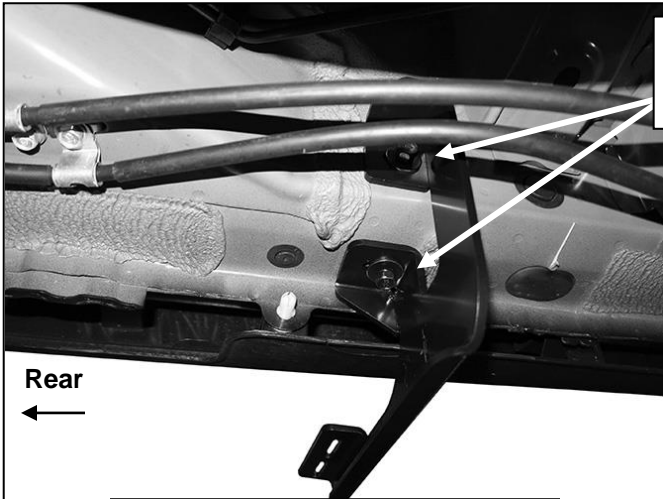

(Fig 9) Rear Bracket-driver side

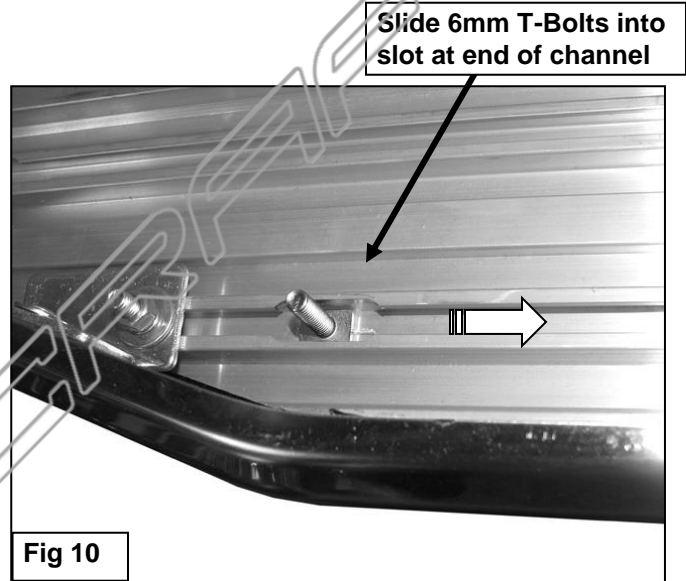

- (2) 6mm Flat Washers
- (2) 6mm Lock Washers
- (2) 6mm Hex Nuts

