

**STX200 ALUMINUM RUNNING BOARD
2014-15 TOYOTA HIGHLANDER**

PARTS LIST:

1	Driver/left Side Running Board	6	10-1.5mm x 50mm Hex Bolts
1	Passenger/right Side Running Board	16	10mm x 27mm x 3mm Flat Washers
2	Front Mounting Brackets	16	10mm Lock Washers
2	Center Mounting Brackets	16	10mm Hex Nuts
1	Driver/left Side Rear Mounting Bracket	12	6mm T-Bolts
1	Passenger/right Side Rear Mounting Bracket	12	6mm x 22mm x 2mm Flat Washers
6	Support Plates	12	6mm Lock Washers
10	10mm Bolt Plates	12	6mm Hex Nuts

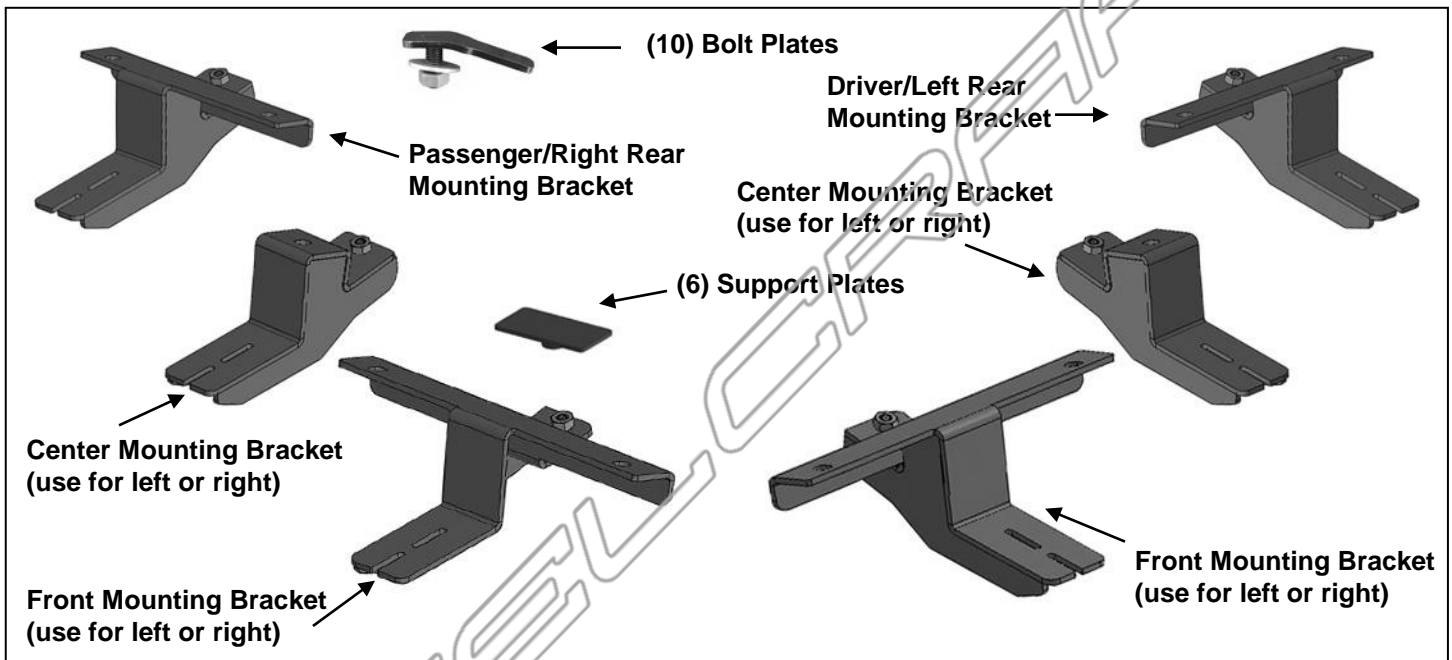

PROCEDURE:

- REMOVE CONTENTS FROM BOX. VERIFY ALL PARTS ARE PRESENT. READ INSTRUCTIONS CAREFULLY BEFORE STARTING INSTALLATION.**
- Starting on the passenger side of the vehicle, locate the (9) rubber plugs along the lower body panel. From the front, remove the 3rd and 4th round plugs, **(Figure 1)**. Select (2) Bolt Plates, **(Figure 2)**. Check the location for body sealant and scrape away excess as necessary, **(Figure 3)**. Insert each Bolt Plate into the factory hole with the long end of the plates facing each other, **(Figures 1 & 3)**. Hold a Front Bracket over the Bolt Plates and line up the (2) mounting holes, **(Figure 4)**. Secure the Bracket to the Bolt Plates with (2) 10mm Flat Washers, (2) 10mm Lock Washers and (2) 10mm Hex Nuts, **(Figure 4)**. Snug but do not tighten hardware at this time.
- Next, select (1) Support Plate, (1) 10mm Hex Nut and (1) 10mm x 50mm Hex Bolt, **(Figure 5)**. Thread the 10mm Hex Nut all the way down the long Hex Bolt. Screw the Hex Bolt and Nut a few threads into and through the Nut welded onto the back tab on the front Bracket. Insert the Support Plate with the welded socket facing down, into the space between the Front Bracket and the floor panel behind the pinch weld, **(Figures 4, 5 & 12)**. Tighten the Hex Bolt into the socket on the Support Plate until the Plate is close to but not touching the floor panel. Do not tighten hardware at this time.
- Next, remove the rubber plug in the 5th (next) hole along the body panel. Repeat **Steps 2—3** to install the center Bracket, **(Figures 6 & 7)**.
- Continue along the body to the 8th and 9th, (last two along body), rubber plugs, **(Figure 6)**. Repeat **Steps 2—3** to install the passenger side rear Bracket, **(Figures 8 & 9)**. **NOTE:** Rear Brackets are offset towards the rear of the vehicle, **(Figure 8)**.

**STX200 ALUMINUM RUNNING BOARD
2014-15 TOYOTA HIGHLANDER**

6. Carefully unwrap the passenger side Running Board. From the front, slide (3) T-Bolts into each channel in the bottom of the Running Board, **(Figure 10)**. Slide the T-Bolts forward or back to line up with the slots in the (3) previously installed Mounting Brackets. Hold the Running Board up to the vehicle at a slight angle and gently push it into position against the rocker panel. Loosen Brackets if necessary. Insert the T-Bolts through the slots in the Brackets, **(Figure 11)**.
7. Attach the Running Board to the Mounting Brackets with the included (6) 6mm Flat Washers, (6) 6mm Lock Washers and (6) 6mm Hex Nuts, **(Figure 11)**. Leave hardware loose at this time.
8. Note that each Bracket has a small amount of height and angle adjustment.
 - a. Check to see if the Running Board is level to the car, front to rear, not level to the ground. To adjust the height of the Bracket, loosen the 10mm Bracket hardware and slide the Brackets up or down the lower body panel. Once level, tighten the 10mm Bolt Plate to Bracket hardware only. The Hex Bolt on the back of the Mounting Bracket for the Support Plate should be completely loose at this time.
 - b. Next, check for level to the ground, side to side only. If the outside edge of the running board is tilted down, tighten the long 10mm x 50mm Hex Bolts on the back of the (3) Mounting Brackets evenly until the Running Board is level, **(Figures 11 & 12)**. If the Running Board is tilted up, loosen the Hex Bolt in the Support Plate a little until the Running Board is level. Once level, tighten all hardware.
9. Repeat **Steps 2—8** for the driver side Running Board installation.
10. Do periodic inspections to the installation to make sure that all hardware is secure and tight.

To protect your investment, wax this product after installing. Regular waxing is recommended to add a protective layer over the finish. Do not use any type of polish or wax that may contain abrasives that could damage the finish.

For stainless steel: Aluminum polish may be used to polish small scratches and scuffs on the finish. Mild soap may be used also to clean the Running Board.

For gloss black finishes: Mild soap may be used to clean the Running Board Brackets.

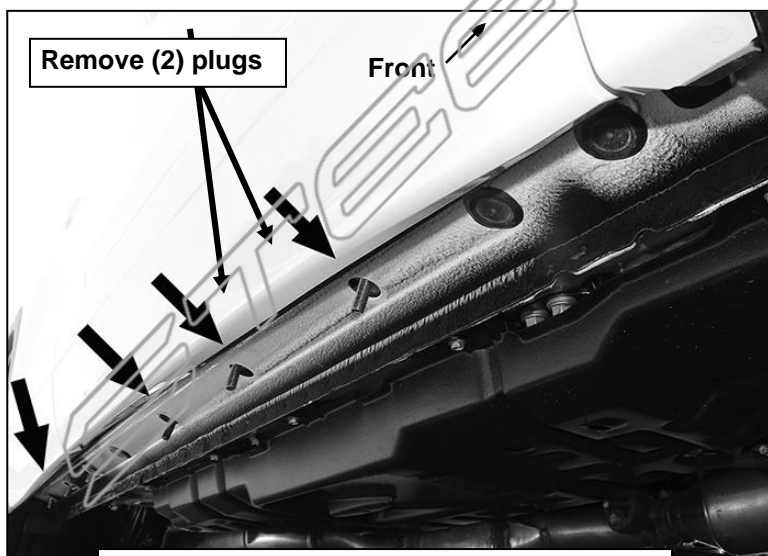

(Fig 1) Use the 3rd and 4th mounting hole from the front fender opening for passenger front Mounting Bracket location



(Fig 2) 10mm Bolt Plate

Passenger Side Installation Pictured



Fig 3) Scrape excess body sealant as necessary from all locations before installing Brackets

- (2) 10mm Flat Washers
- (2) 10mm Lock Washers
- (2) 10mm Hex Nuts

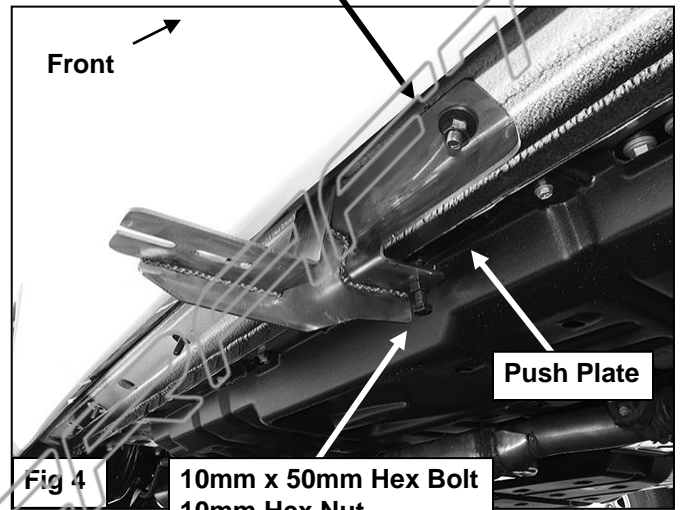
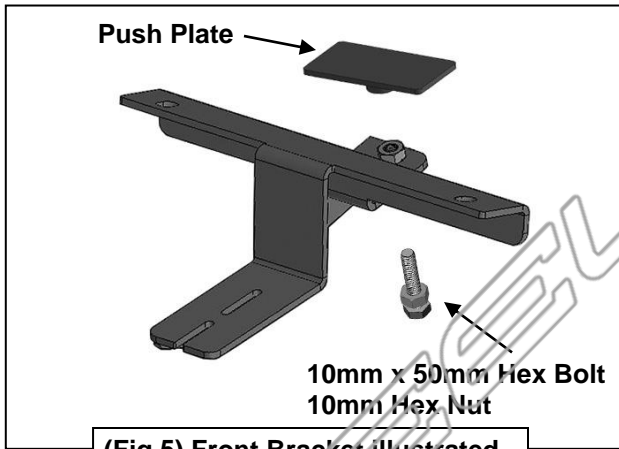

Fig 4

- 10mm x 50mm Hex Bolt
- 10mm Hex Nut

Push Plate



Push Plate

- 10mm x 50mm Hex Bolt
- 10mm Hex Nut

(Fig 5) Front Bracket illustrated

Mounting location for Rear Bracket
(use last 2 holes along body)

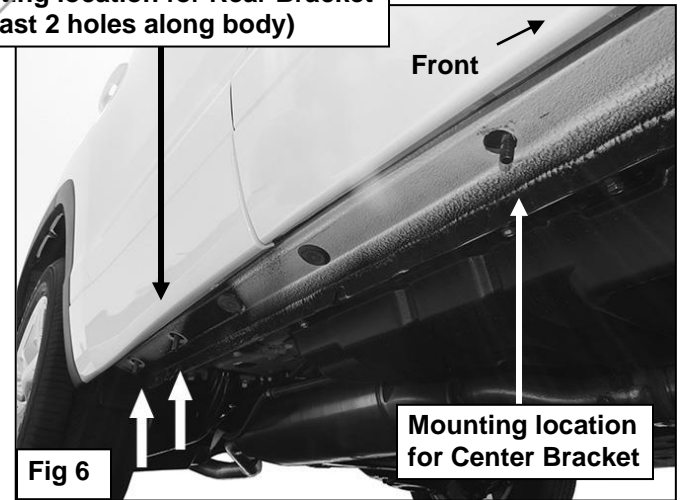
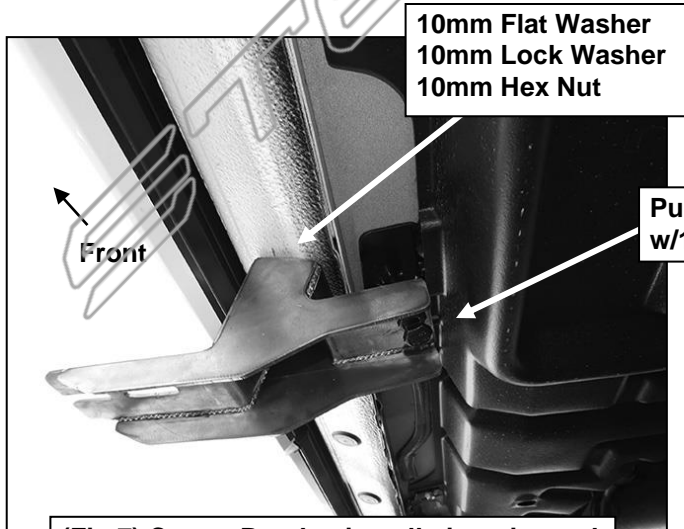

Fig 6

Front

Mounting location for Center Bracket



- 10mm Flat Washer
- 10mm Lock Washer
- 10mm Hex Nut

Push Plate w/10mm Hex Bolt

(Fig 7) Center Bracket installation pictured

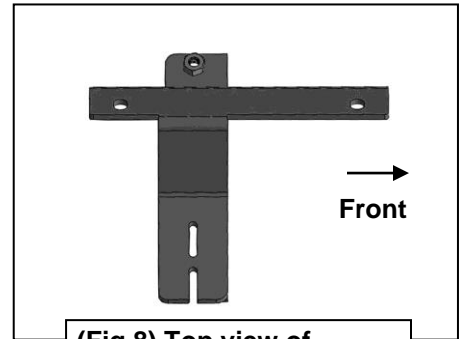

(Fig 8) Top view of passenger rear Bracket

Front

Passenger Side Installation Pictured

Push Plate w/10mm Hex Bolt

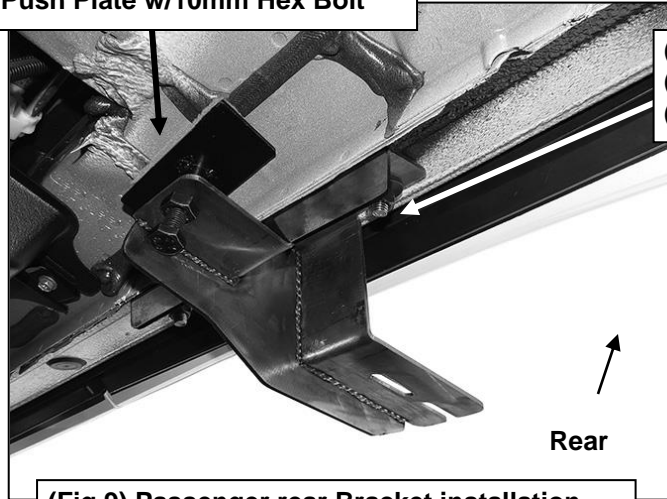

(2) 10mm Flat Washers
(2) 10mm Lock Washers
(2) 10mm Hex Nuts

(Fig 9) Passenger rear Bracket installation

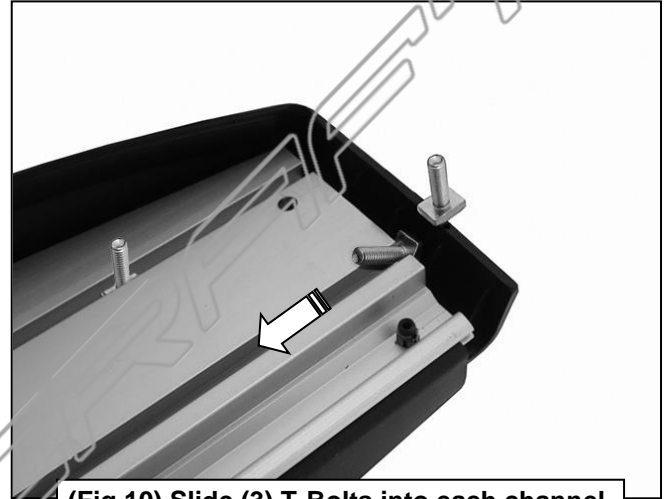

(Fig 10) Slide (3) T-Bolts into each channel

(2) 6mm Flat Washers
(2) 6mm Lock Washers
(2) 6mm Hex Nuts

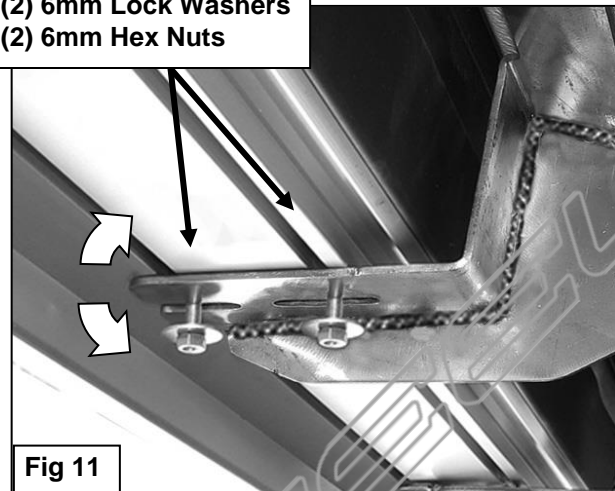

Fig 11

Tighten the 10mm x 50mm Hex Bolt against the Push Plate on each Bracket until the Bracket is level to the ground and Running Board. Once properly adjusted, tighten the 10mm Jam Nut to lock adjustment in place (Figure 12)

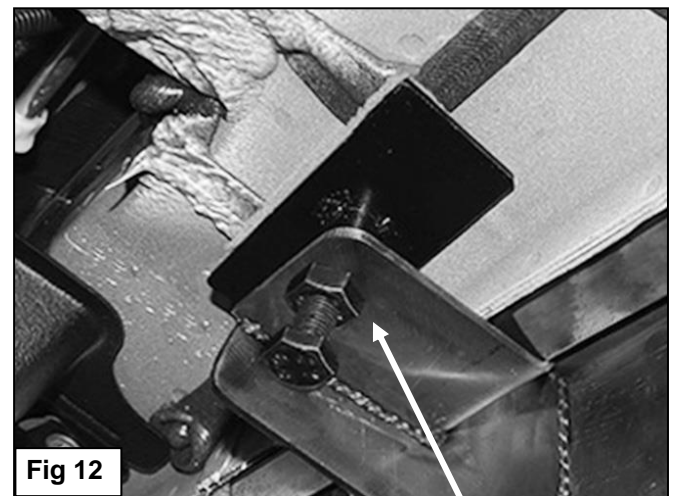

Fig 12

Tighten 10mm Jam Nut to lock adjustment in place



Complete Installation