

INSTALLATION INSTRUCTIONS
SIDEBAR
02-05 FORD EXPLORER 4 DOOR
PART NUMBER

PARTS LIST:

1	Passenger Sidebar	4	10-1.50mm x 120mm Hex Head Bolts
1	Driver Sidebar	2	10-1.50mm x 100mm Hex Head Bolts
3	"A" Mounting Brackets	24	10-1.50mm x 30mm Hex Head Bolts
3	"B" Mounting Brackets	6	10-1.50mm Clip Nuts
4	85mm Tube Spacers	12	10mm Hex Head Nuts
2	65mm Tube Spacers	30	10mm ID x 21mm OD x 1.5mm Flat Washers
		30	10mm Lock Washers

Driver Side Mounting Brackets

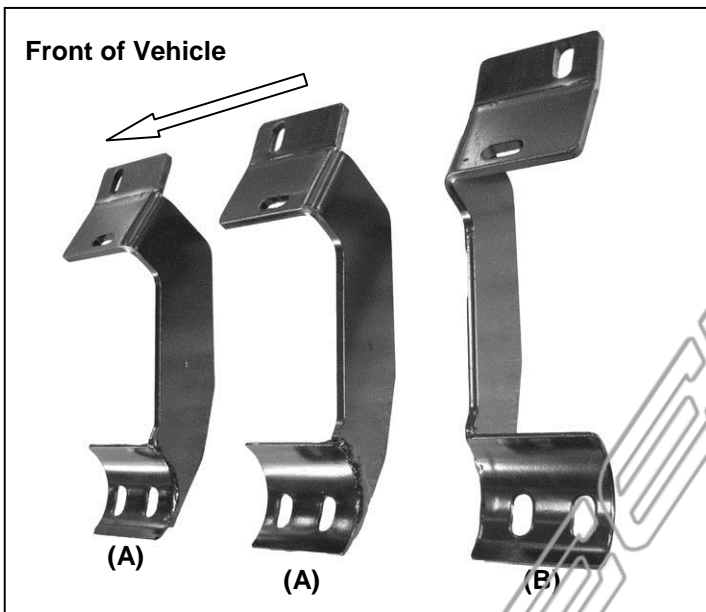

Passenger Side Mounting Brackets

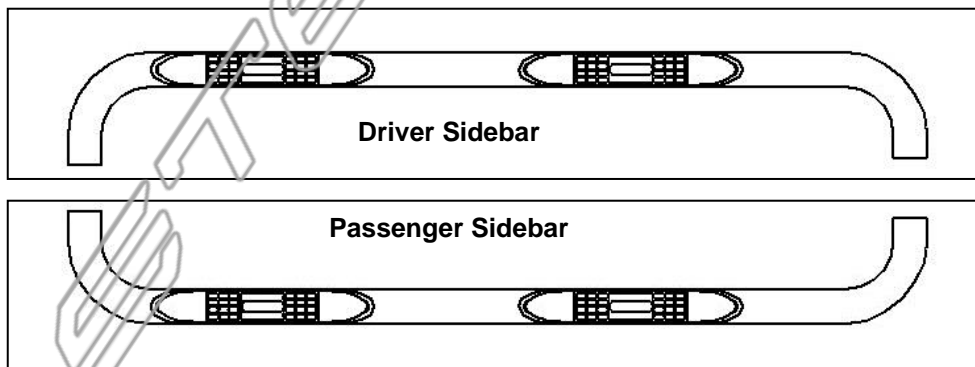
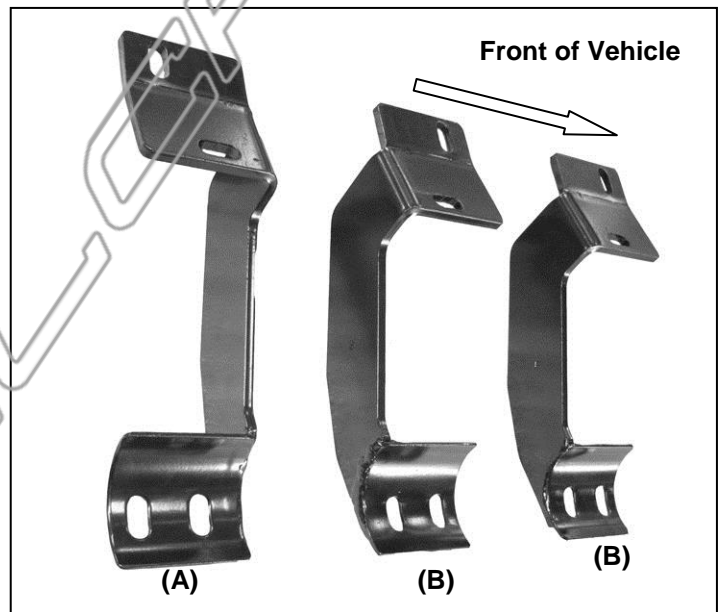

(Please refer to figure above for Bracket configuration before starting the installation)

PROCEDURE:

1. REMOVE CONTENTS FROM BOX. VERIFY ALL PARTS ARE PRESENT. READ INSTRUCTIONS CAREFULLY BEFORE STARTING INSTALLATION.
2. From underside of vehicle, locate the two front factory holes on the driver side floor panel, located by the front tire. With the threaded nut facing up, insert (1) 10mm Clip Nut through larger hole. Orient Clip Nut to engage into the smaller hole (**Figure 1**).
3. Partially hang driver front Mounting Bracket (again refer to figure above for bracket configuration) to pinch weld using (1) 10mm x 30mm Hex Head Bolt, (1) 10mm Hex Nut, (1) 10mm Lock Washer, and (1) 10mm Flat Washer (**Figure 6**). **NOTE:** If vehicle is equipped with factory running boards, use the factory bolt to attach Mounting Bracket to pinch weld.
4. Place (1) 65mm (smaller) Tube Spacer between the Mounting Bracket and the already installed Clip Nut. Insert (1) 10mm x 100mm Hex Head Bolt through tab on the Mounting Bracket and Tube Spacer and to Clip Nut (**Figure 6**). Do not tighten at this time.
5. Repeat steps 2 – 4 for driver center and driver rear Mounting Brackets. Depending upon your vehicle, the center factory hole might be too small for the Clip Nut, file the Clip Nut until you are able to mount it. **NOTE:** You will be using 85mm (larger) Tube Spacers with 10mm x 120mm Hex Head Bolts on the center and rear Mounting Brackets.
6. Once all three Mounting Brackets are partially mounted, carefully position driver Sidebar onto Mounting Brackets. Attach Sidebar to Mounting Brackets using (4) 10mm x 30mm Hex Head Bolts, (4) 10mm Lock Washers, and (4) 10mm Flat Washers (**Figure 6**). **NOTE:** Rear Mounting Bracket uses (2) bolts to mount to Sidebar, center and front Mounting Brackets use (1) bolt each. Do not tighten at this time.
7. Level and adjust Sidebar; then tighten all hardware at this time.
8. Repeat steps 2-7 for passenger side.
9. Do periodic inspections to the installation to make sure all hardware is secure and tight.

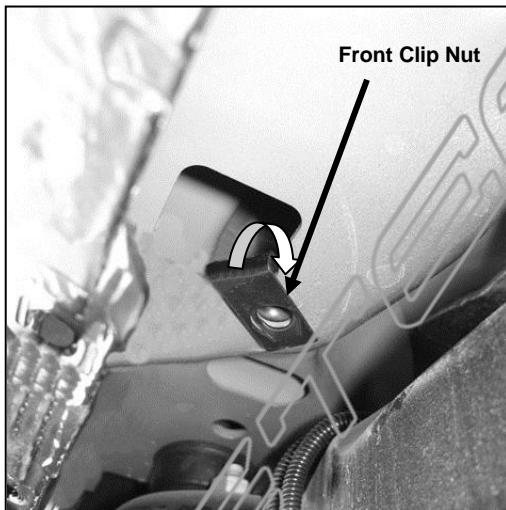

Figure 1

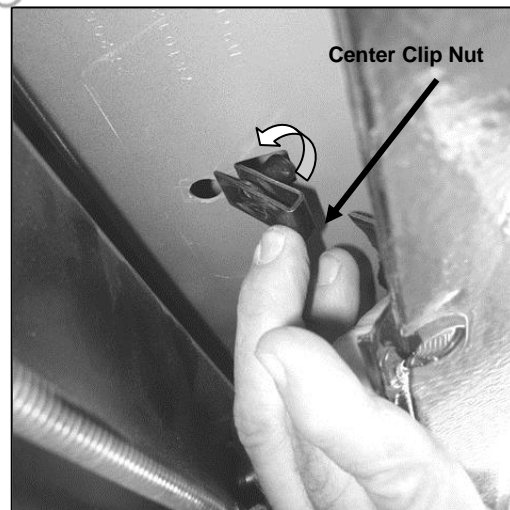

Figure 2

Passenger Side Mounting Brackets Shown

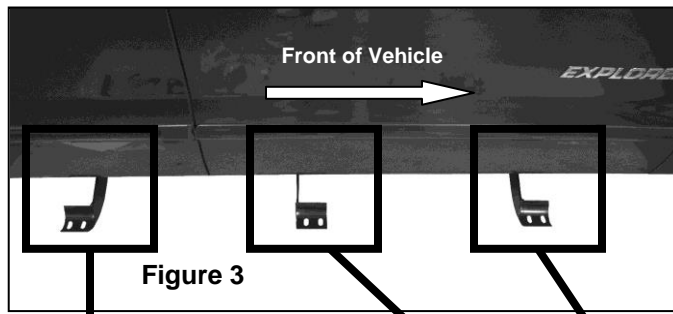
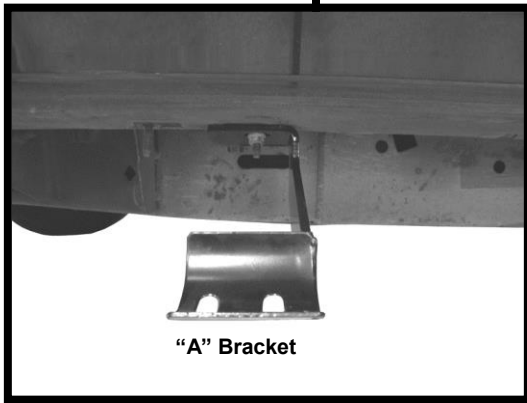
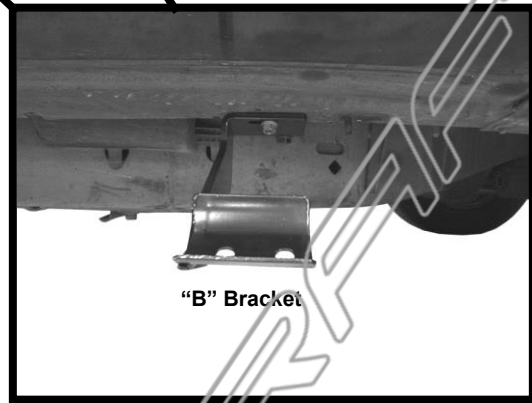

Figure 3



"A" Bracket

Figure 4



"B" Bracket

Figure 5

- 10mm x 120mm Hex Bolt
- 10mm Lock Washer
- 10mm Flat Washer

- (To pinch weld)
- 10mm x 30mm Hex Bolt
 - 10mm Lock Washer
 - 10mm Hex Nut
 - 10mm Flat Washer

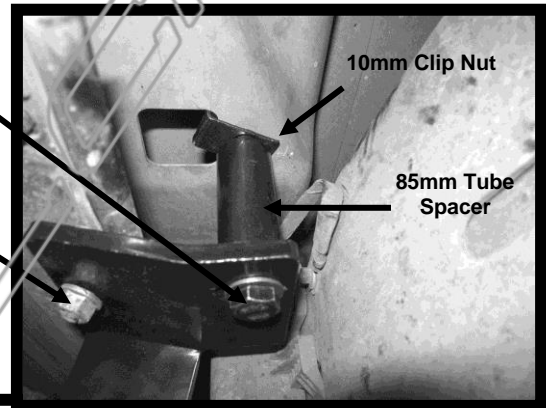

Rear Mounting Bracket shown

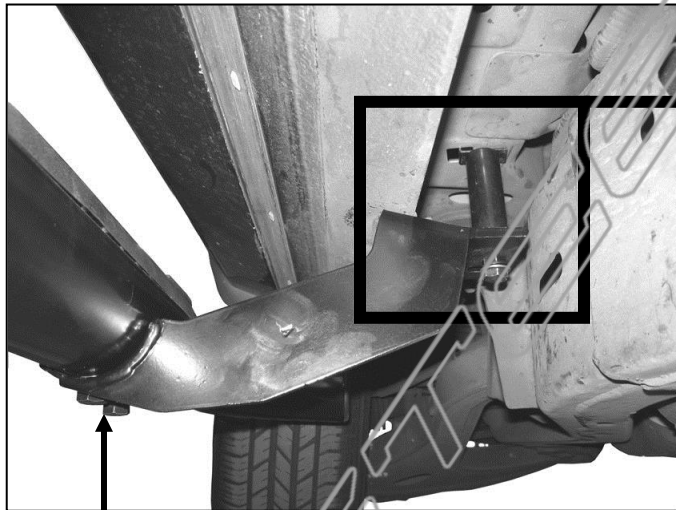

Figure 6

- 10mm x 30mm Hex Bolt
- 10mm Lock Washer
- 10mm Flat Washer

Installation Complete



Figure 7