

PARTS LIST: -

Qty	Description	Qty	Description
1	Driver / Left Sidebar	2	12mm Plastic Retainers
1	Passenger / Right Sidebar	8	10mm Plastic Retainers
1	Driver / Left Front Mounting Bracket	2	12mm x 32mm OD x 3mm Flat Washers
1	Passenger / Right Front Mounting Bracket	2	12mm Lock Washers
1	Driver / Left Center Mounting Bracket	2	12mm Hex Nuts
1	Passenger / Right Center Mounting Bracket	8	10mm x 27mm OD x 3mm Flat Washers
1	Driver / Left Rear Mounting Bracket	8	10mm Lock Washers
1	Passenger / Right Rear Mounting Bracket	8	10mm Hex Nuts
2	12mm x 35mm Special Bolt Plate (Rear)	12	8-1.25mm x 30mm Hex Bolts
5	10mm x 35mm Button Head Bolt Plates	12	8mm x 24mm OD x 2mm Flat Washers
2	10mm x 35mm T-Bolts (Both Front Outer)	12	8mm Lock Washers
1	10mm x 35mm Small T-Bolts (Driver Front Inner only)		

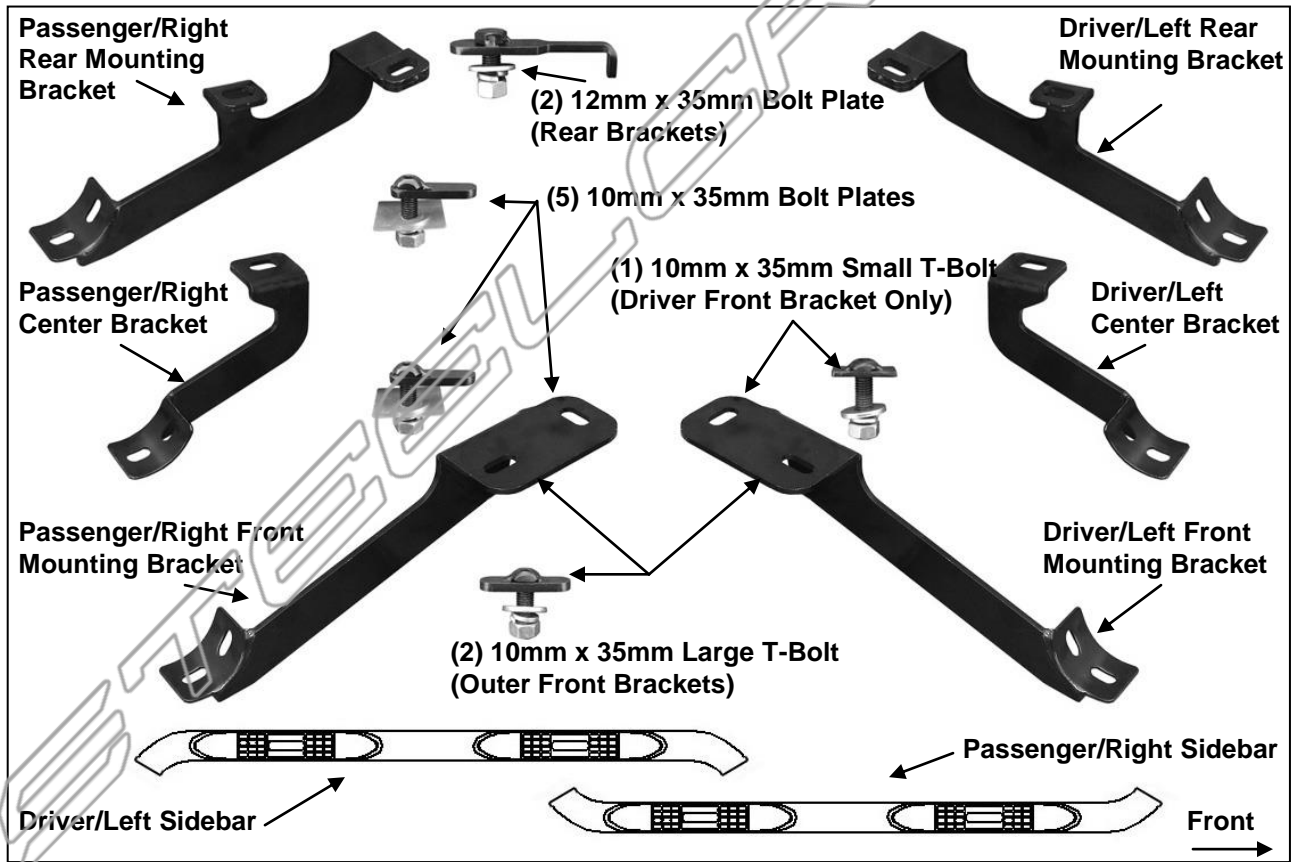

PROCEDURE:

1. REMOVE CONTENTS FROM BOX. VERIFY ALL PARTS ARE PRESENT. READ INSTRUCTIONS CAREFULLY BEFORE STARTING INSTALLATION. CUTTING IS REQUIRED. ASSISTANCE IS RECOMMENDED.
2. Start installation under the driver side of the vehicle. **NOTE:** To help determine the correct mounting holes to use, hold the front Bracket up in position against the floor panel and line up the Bracket with the correct holes, (Fig. 1). **IMPORTANT:** Use a putty knife or flat screwdriver to scrape any excess undercoating or body sealant from all mounting areas. Brackets must sit flat against the mounting locations.

a. Driver side front Bracket installation:

Select (1) 10mm x 35mm Small T-Bolt and (1) 10mm Plastic Retainer, (Fig. 2A). Partially thread the Retainer onto the T-Bolt. Insert the T-Bolt into the inner factory oval hole, (Fig. 1 & 3). Rotate the T-Bolt 90-degrees so that the plate is across the slot. Thread the Retainer down until it is tight against the floor panel. The Retainer is designed to help hold the T-Bolt in place during Bracket installation.

Next, insert (1) 10mm x 35mm Large T-Bolt with (1) Plastic Retainer into the outer oval hole in the floor panel next to the pinch weld as previously described, (Fig. 2B & 3).

b. Passenger side front Bracket installation:

IMPORTANT-Repeat the previous **Step 2a** for passenger side Bracket installation but note that the inner mounting tab on the front Bracket will use (1) 10mm x 35mm Button Head Bolt Plate, (same bolt plate as used on center and rear Brackets), inserted into a round hole in place of the 10mm Small T-Bolt, (Fig. 2B, 4 & 5). Do not use the Small T-Bolt for passenger side front Bracket.

3. Hang the driver side Front Bracket from the T-Bolts with (2) 10mm Flat Washers, (2) 10mm Lock Washers and (2) 10mm Hex Nuts, (Fig. 6). Do not tighten hardware at this time.
4. Release the plastic clips attaching the lower plastic rocker panel cover to the body, (Fig. 7).
5. Measure 40" back from the bottom corner of the wheel opening to locate the correct factory hole under the plastic rocker cover for the center Bracket, (Fig. 8). Pull plastic cover outward to access the hole, (Fig. 10). Partially thread (1) 10mm Plastic Retainer onto (1) 10mm x 35mm Button Head Bolt Plate, (Fig. 9). Insert Bolt Plate into the round hole and thread the Retainer down against the body, (Fig. 10).
6. Select the driver side center Bracket, (Fig. 11A) insert the Center Bracket into the approximate position, (Fig. 11B). Mark the Bracket location on the bottom edge of the plastic cover, (Fig. 12). Cut a small slot in the bottom edge of the cover to clear the Bracket. Bolt the Bracket to the Bolt Plate with (1) 10mm Flat Washer, (1) 10mm Lock Washer and (1) 10mm Hex Nut, (Fig. 13). Leave hardware loose.
7. Move to the rear location and remove the plastic cover on the floor panel, (Fig. 14). Locate the small round hole under the plastic rocker cover, (Fig. 16). Select (1) 10mm x 35mm Button Head Bolt Plate and (1) 10mm Plastic Retainer (Fig. 15). Insert the Bolt Plate into the round hole as described in **Step 5**, (Fig. 16 & 17).
8. Next, locate the large round hole in the floor panel. Insert (1) 12mm x 35mm Bolt Plate into the large round hole and out the smaller hole toward the front, (Fig. 18 & 19). Slide the driver side Rear Bracket under the plastic rocker cover and over the (2) Bolt Plates, (Fig. 20). Secure the Bracket to the outer 10mm Bolt Plate with (1) 10mm Flat Washer, (1) 10mm Lock Washer and (1) 10mm Hex Nut. Attach the Bracket to the Larger 12mm Bolt Plate with (1) 12mm Flat Washer, (1) 12mm Lock Washer and (1) 12mm Hex Nut, (Fig. 20). Do not tighten hardware at this time.
9. Hold the plastic cover removed in **Step 7**, up in position. Trace the location of the rear Bracket onto the cover, (Fig. 21). Carefully cut the cover to clear the Bracket, (Fig. 22A & 22B). **IMPORTANT**: Cut as little as possible from the cover. Do not cut off the mounting area for the factory hardware, (Fig. 22B). Reinstall the plastic cover and all plastic clips holding the bottom of the rocker cover to the body panel. Check the direction of the cradles on all Brackets before proceeding, (Fig. 23).
10. Carefully unwrap and select the driver Sidebar. Place the Sidebar in position on top of the (3) Brackets. **NOTE**. It may be necessary to loosen the Brackets slightly to line up the cradles with the threaded inserts in the Sidebars. Bolt the Sidebar to the Brackets with (6) 8mm x 30mm Hex Bolts, (6) 8mm Lock Washers and (6) 8mm flat washers, (Fig. 24).
11. Level and adjust the Sidebar and tighten all hardware.
12. Repeat **Steps 2 – 11** for passenger Sidebar installation. **NOTE**: See specific passenger side front Bracket installation info in **Step 2b**.
13. Do periodic inspections to the installation to make sure that all hardware is secure and tight.

To protect your investment, wax this product after installing. Regular waxing is recommended to add a protective layer over the finish. Do not use any type of polish or wax that may contain abrasives that could damage the finish.

For stainless steel: Aluminum polish may be used to polish small scratches and scuffs on the finish. Mild soap may be used also to clean the Sidebar.

For gloss black finishes: Mild soap may be used to clean the Sidebar.

Driver/Left Side Installation Pictured

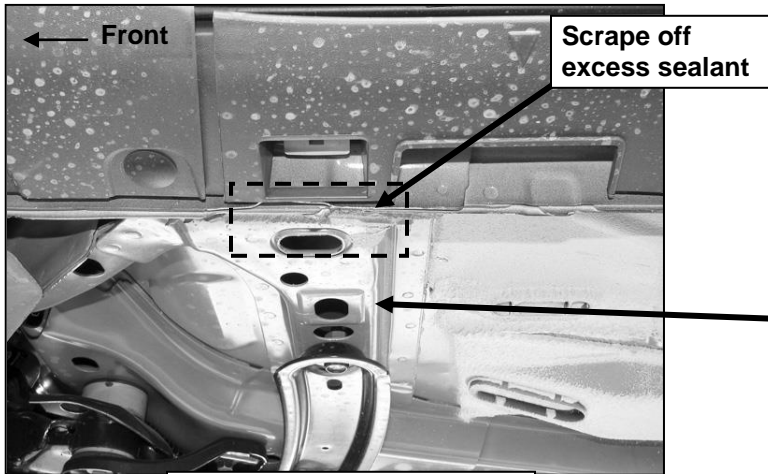

(Fig 1) Driver side front mounting location pictured

(Fig 2A) Small 10mm x 35mm T-Bolt for driver side inner front bracket only

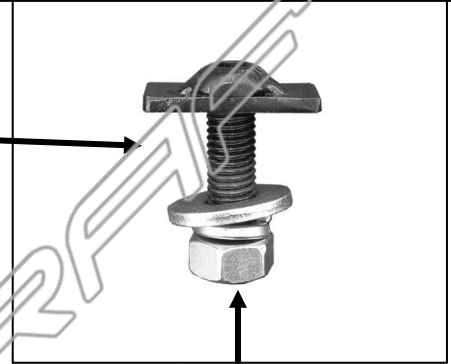

(Fig 2B) Large 10mm x 35mm T-Bolt for driver and passenger side outer location on front brackets only

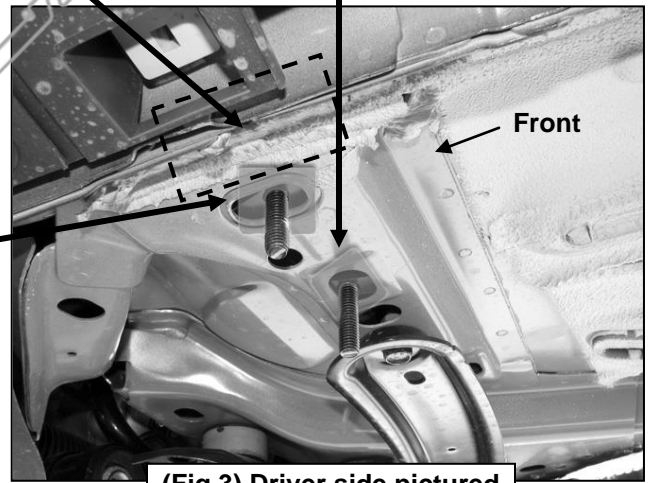
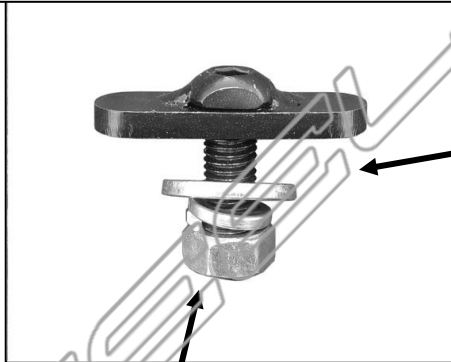

(Fig 3) Driver side pictured

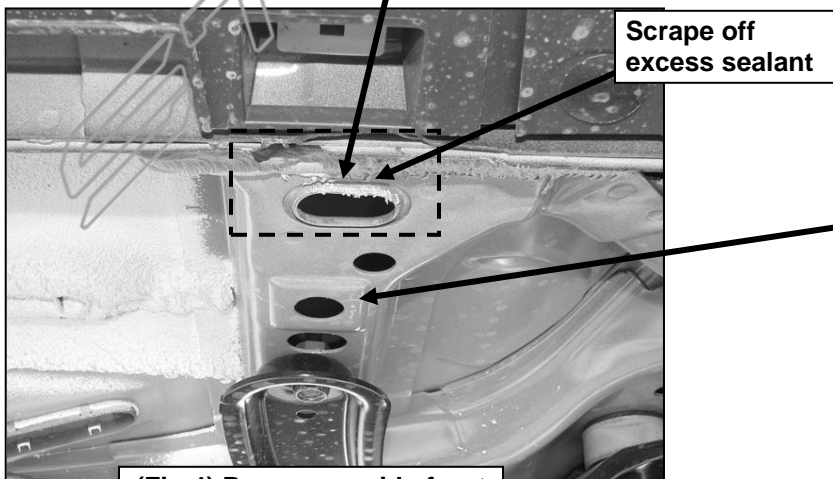

(Fig 4) Passenger side front mounting location pictured

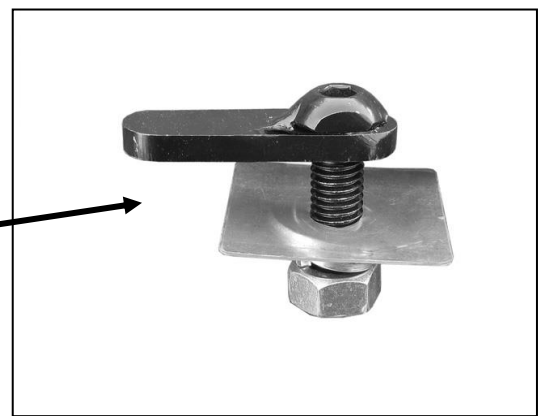

(Fig 5) Use 10mm x 35mm Bolt Plate for passenger side inner location (same bolt plate used on center and rear brackets)

Driver Side Installation Pictured

- (2) 10mm Flat Washers
- (2) 10mm Lock Washers
- (2) 10mm Hex Nuts

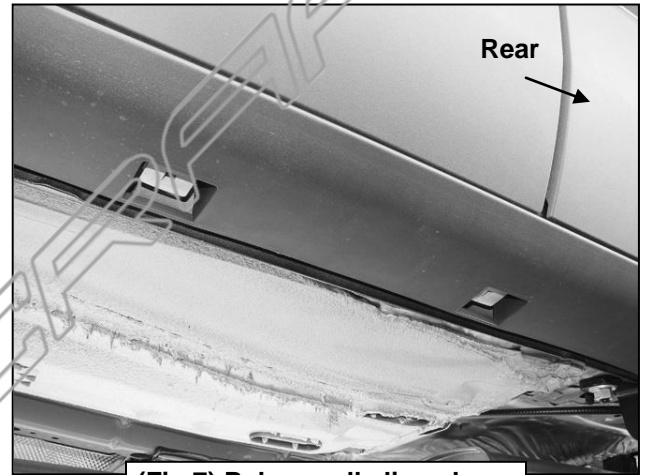
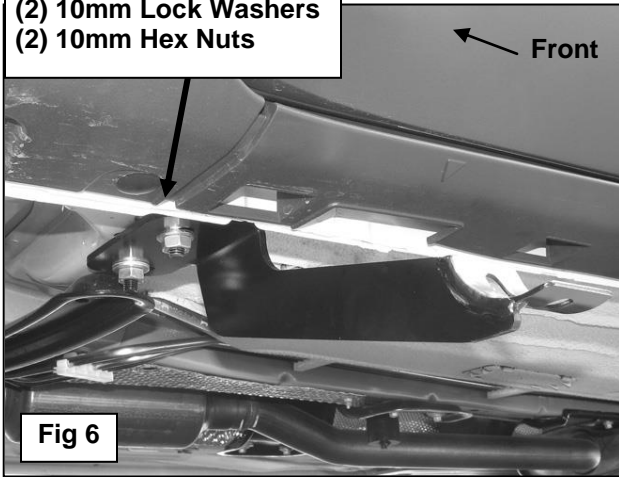

(Fig 7) Release all clips along bottom of rocker panel cover

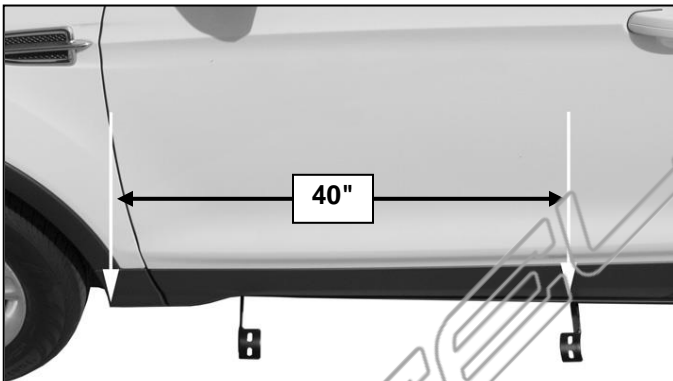

(Fig 8) Measure approximately 40 inches from bottom corner of wheel opening along rocker panel to locate factory hole for center Bracket

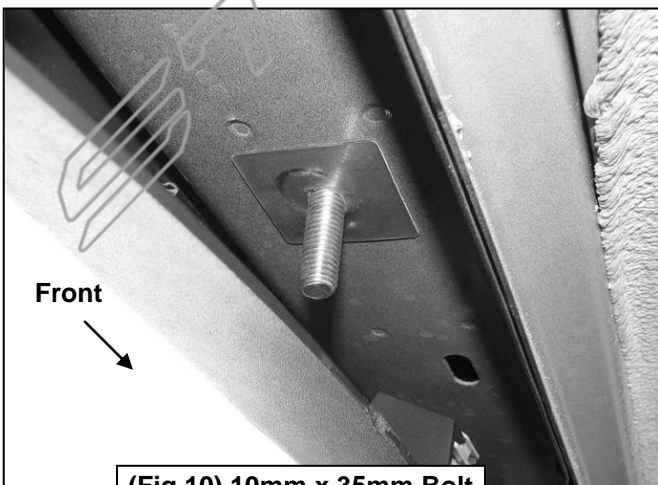

(Fig 10) 10mm x 35mm Bolt Plate with Plastic Retainer



Driver Side Installation Pictured

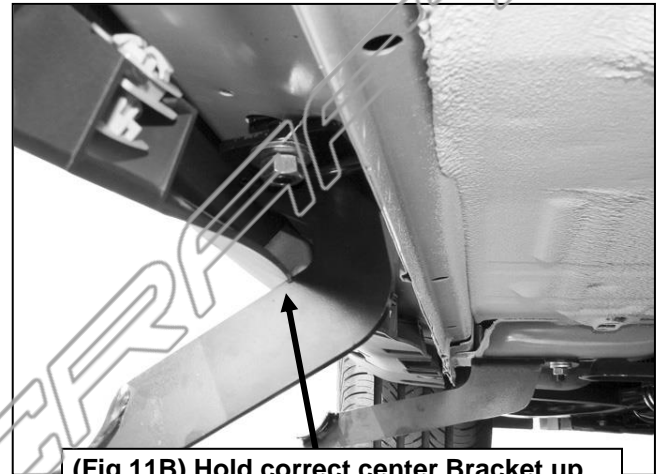
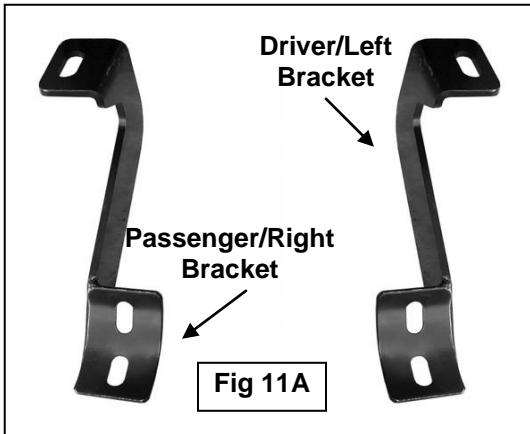

(Fig 11B) Hold correct center Bracket up in place to determine area to cut from bottom edge of rocker panel cover

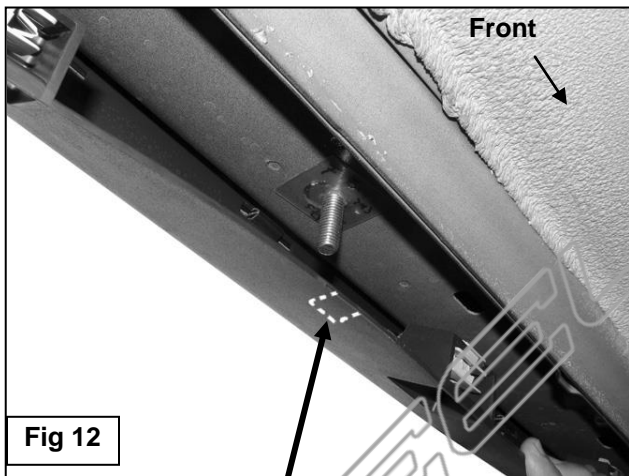

Dotted line represents area to cut from bottom edge of rocker panel cover to clear center Bracket

- 10mm Flat Washer
- 10mm Lock Washer
- 10mm Hex Nut

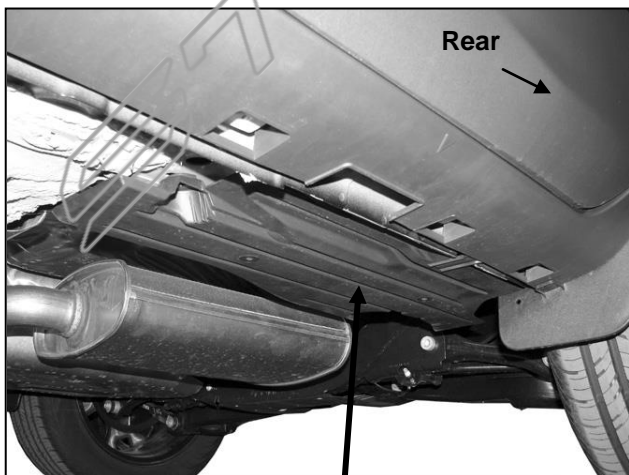
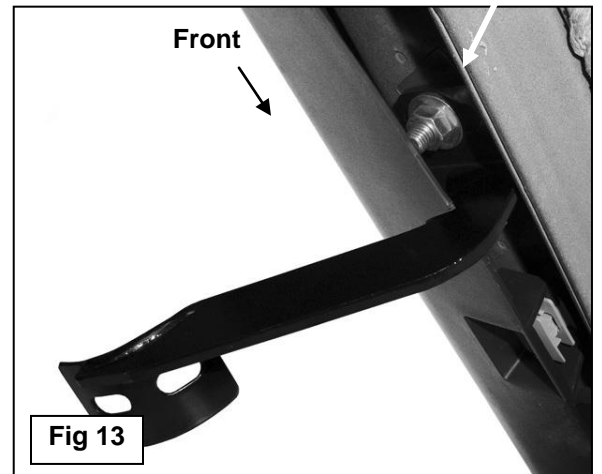

(Fig 14) Remove plastic cover

Driver Side Installation Pictured

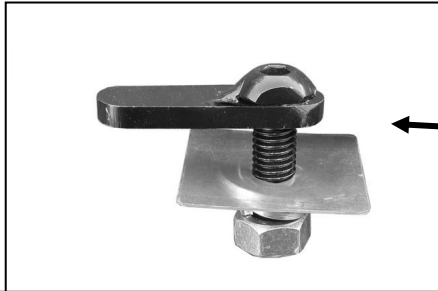

(Fig 15) 10mm x 35mm Bolt Plate

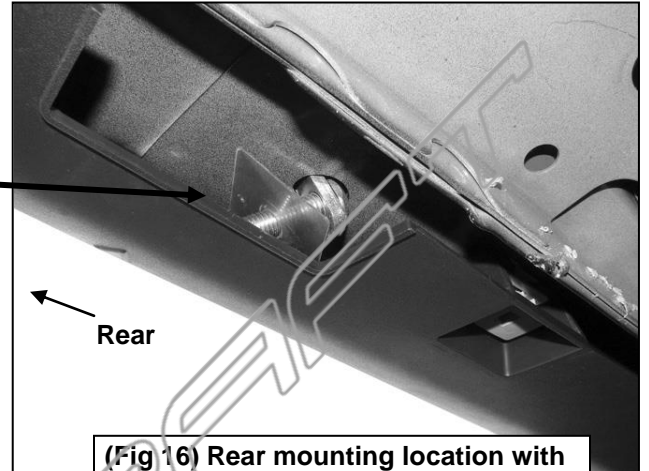

(Fig 16) Rear mounting location with Bolt Plate pictured from below

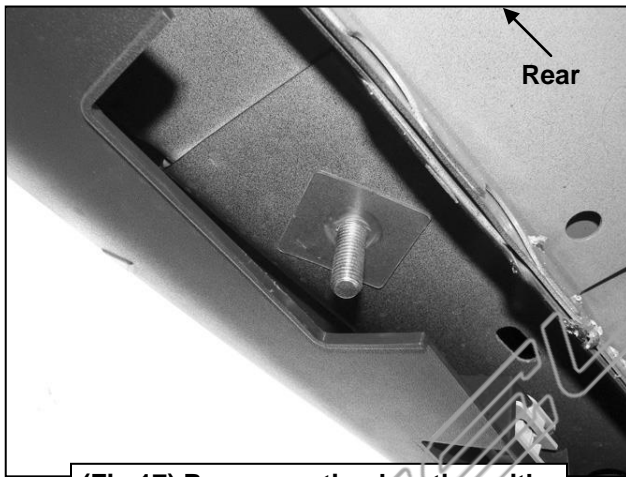

(Fig 17) Rear mounting location with Bolt Plate pictured from below

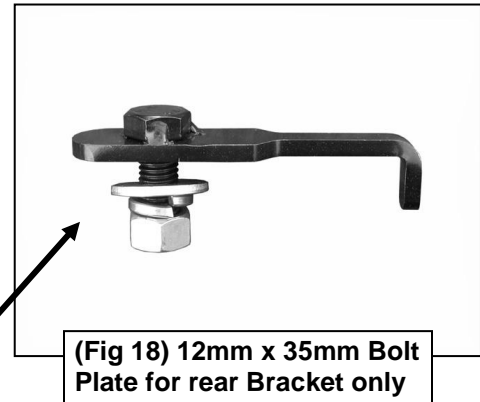

(Fig 18) 12mm x 35mm Bolt Plate for rear Bracket only

12mm Flat Washer
12mm Lock Washer
12mm Hex Nut

10mm Flat Washer
10mm Lock Washer
10mm Hex Nut



(Fig 19) Insert 12mm Bolt Plate into large hole and out smaller hole

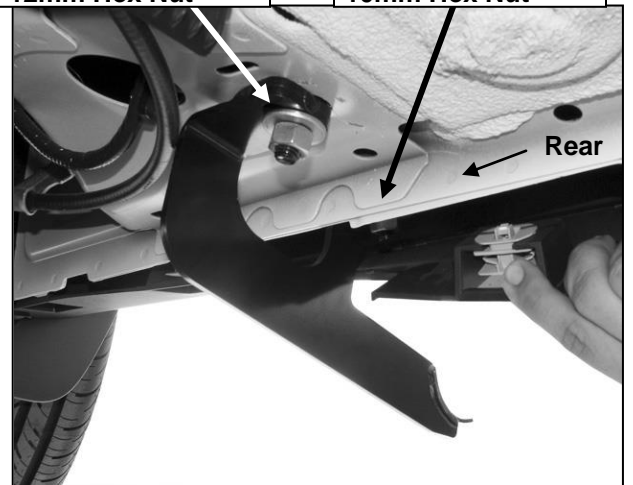

(Fig 20) Rear Bracket pictured from below

Driver Side Installation Pictured



(Fig 21) Hold plastic cover up in position to determine area to cut from cover

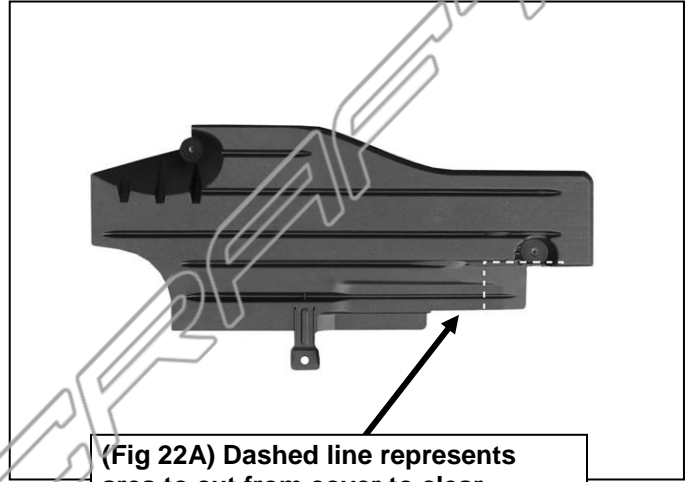

(Fig 22A) Dashed line represents area to cut from cover to clear

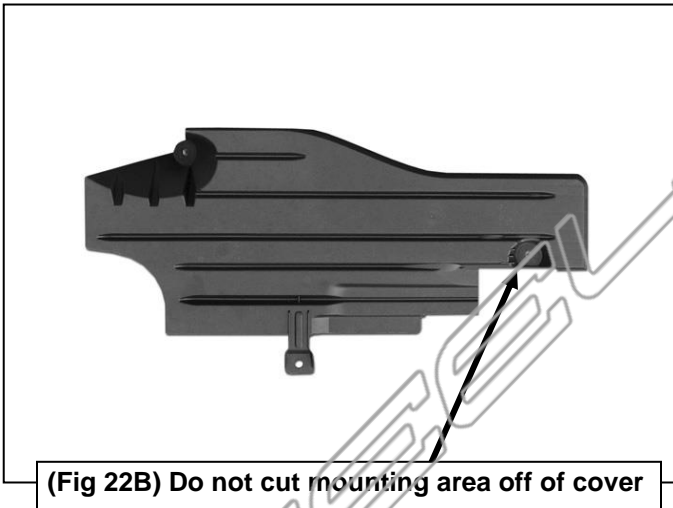

(Fig 22B) Do not cut mounting area off of cover

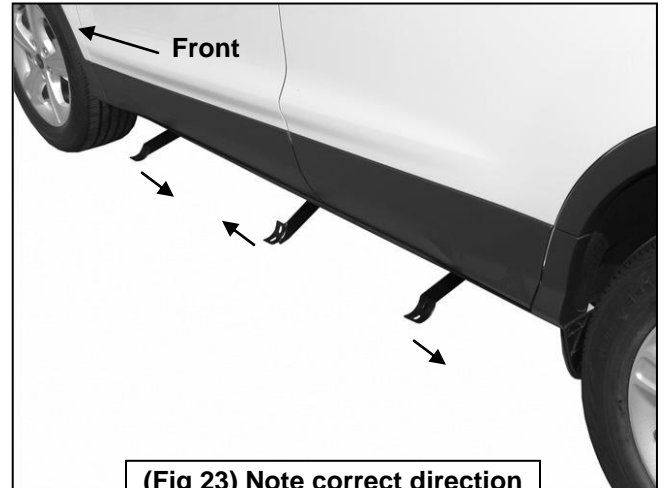

(Fig 23) Note correct direction of cradles on Brackets

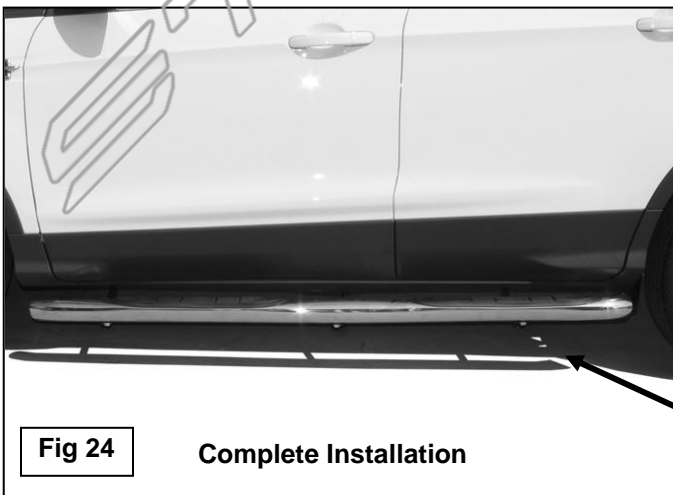

Fig 24

Complete Installation

- 8mm x 30mm Hex Bolts
- 8mm Flat Washers
- 8mm Lock Washers