

INSTALLATION INSTRUCTIONS

**90-DEGREE BENT END SIDEBARS
2015-18 FORD F150 REGULAR CAB
2017-18 FORD SUPER DUTY REGULAR CAB**

STEELERRAFT

PARTS LIST:

1	Driver/left Sidebar	12	8mm Plastic Washers
1	Passenger/right Sidebar	4	1/2" x 2" Hex Bolts
1	Driver/left front Sidebar Bracket	4	1/2" x 1-1/4" OD x 3/32" Flat Washers
1	Passenger/right front Sidebar Bracket	4	1/2" Lock Washers
1	Driver/left rear Sidebar Bracket	12	8mm x 24mm OD x 2mm Washers
1	Passenger/right rear Sidebar Bracket	12	8-1.25mm Nylon Lock Nuts

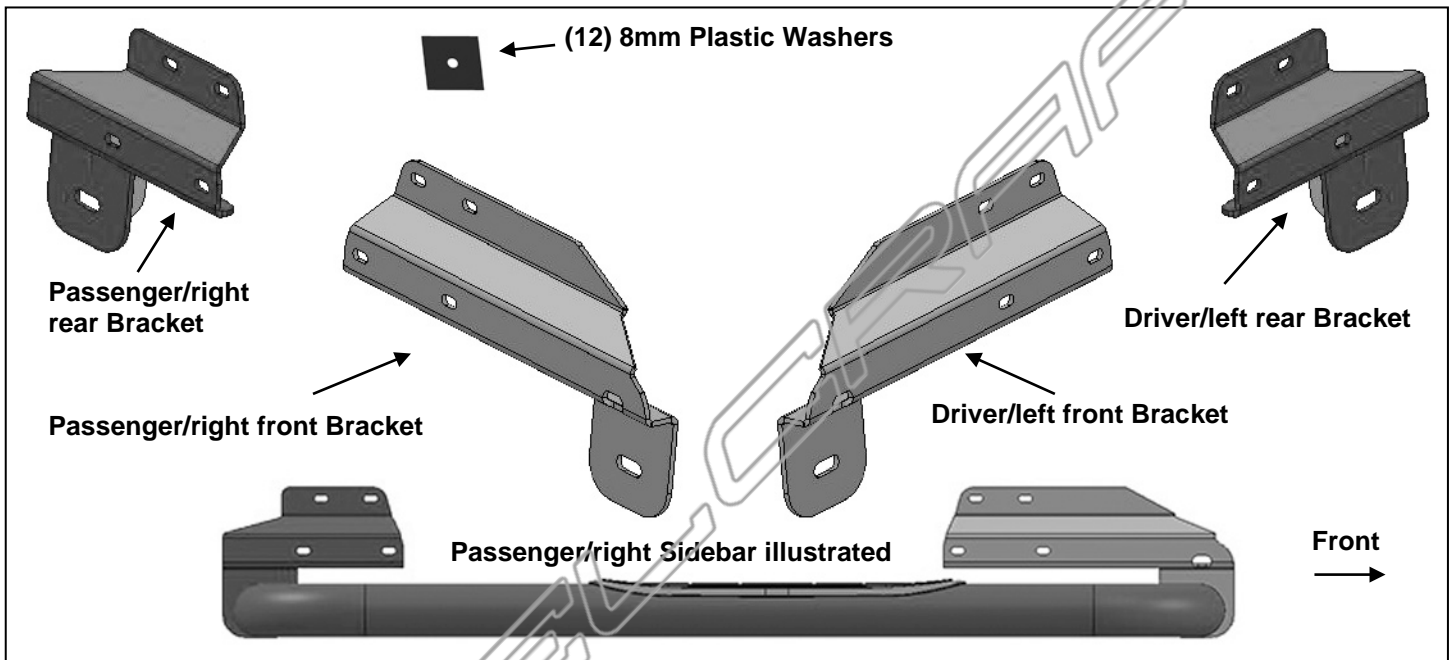

PROCEDURE:

REMOVE CONTENTS FROM BOX. VERIFY ALL PARTS ARE PRESENT. READ INSTRUCTIONS CAREFULLY BEFORE STARTING INSTALLATION. ASSISTANCE IS RECOMMENDED.

1. Start the installation under the driver side of the vehicle. Locate the front and rear factory running board mounting locations along the inner side of the body, **(Figure 1)**.
2. Slide (1) Plastic Washer over each factory mounting stud in the body panel, **(Figures 2 & 3)**.
IMPORTANT: The Plastic Washers are designed to prevent corrosion between the aluminum body panel and the steel mounting brackets. **Do not install the Brackets without the Plastic Washers.**
3. Select (1) driver side front Mounting Bracket. Attach the Mounting Bracket to the (3) factory studs with (3) 8mm Flat Washers and (3) 8mm Nylon Lock Nuts, **(Figure 4)**. Snug but do not fully tighten the hardware.
4. Repeat **Steps 1—3** to install the driver side rear Bracket, **(Figure 5)**.
5. Select the driver/left Sidebar. With assistance, position the Sidebar up to the (2) Mounting Brackets. Attach the Sidebar to the Mounting Brackets with the included (2) 1/2" x 2" Hex Bolts, (2) 1/2" Lock Washers, and (2) 1/2" Flat Washers, **(Figure 5)**. Snug but do not tighten at this time.
6. Level and adjust the Sidebar and tighten all hardware.
7. Repeat **Steps 1—6** to install the passenger/right Sidebar.
8. Do periodic inspections to the installation to make sure that all hardware is secure and tight.

To protect your investment, wax this product after installing. Regular waxing is recommended to add a protective layer over the finish. Do not use any type of polish or wax that may contain abrasives that could damage the finish.

For stainless steel: Aluminum polish may be used to polish small scratches and scuffs on the finish. Mild soap may be used also to clean the Sidebar.

For gloss black finishes: Mild soap may be used to clean the Sidebar.

Driver/left Side Installation Pictured

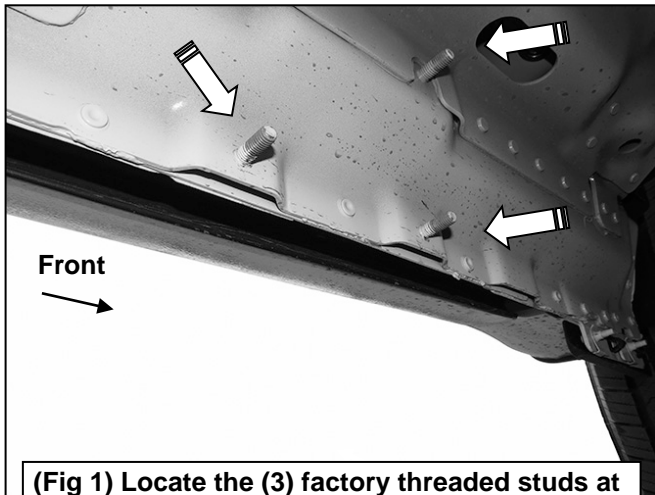

(Fig 1) Locate the (3) factory threaded studs at each location. Driver side front pictured

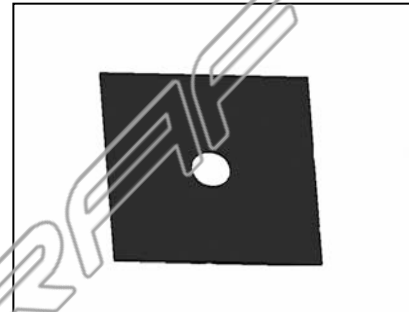

(Fig 2) Plastic Insulation Washer

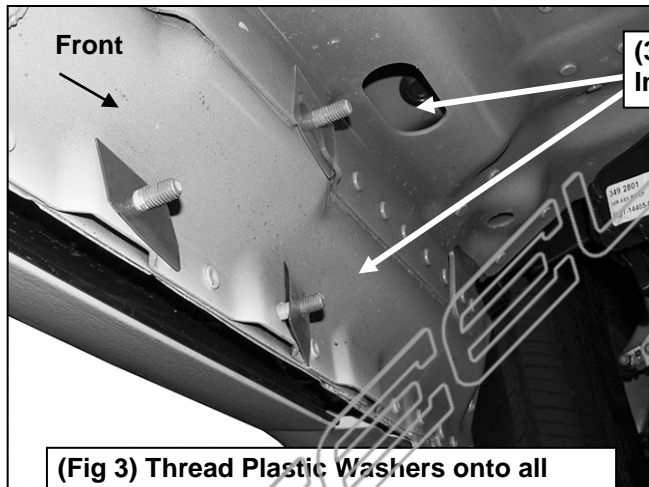

(3) Plastic Insulation Washers

(Fig 3) Thread Plastic Washers onto all mounting studs. Driver side front pictured

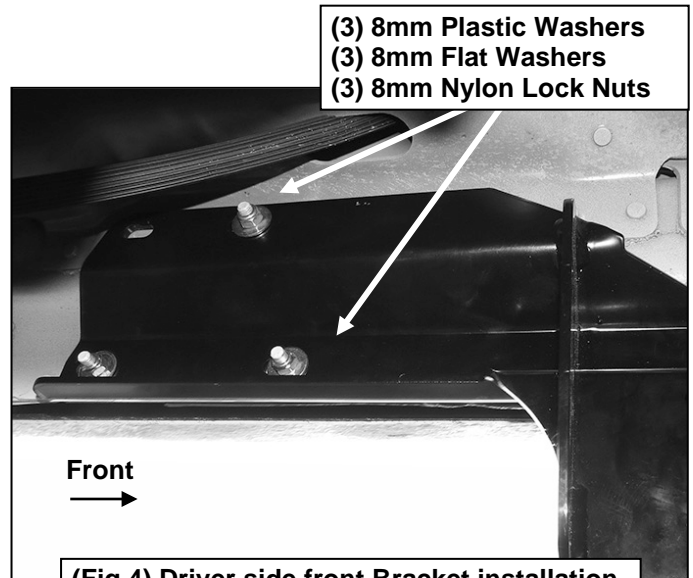

**(3) 8mm Plastic Washers
(3) 8mm Flat Washers
(3) 8mm Nylon Lock Nuts**

(Fig 4) Driver side front Bracket installation

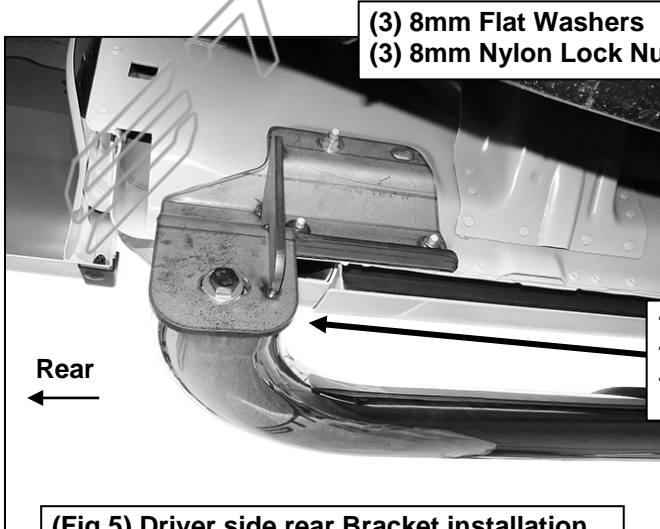

**(3) 8mm Flat Washers
(3) 8mm Nylon Lock Nuts**

**1/2" x 2" Hex Bolts
1/2" Flat Washers
1/2" Lock Washers**

(Fig 5) Driver side rear Bracket installation