

**3" 90 DEGREE BENT END SIDEBARS
2019 DODGE RAM 1500 CREW CAB**

PARTS LIST:

1	Driver/left side 3" 90 deg. Bent End Sidebar	1	Passenger/right side Rear Support Bracket
1	Passenger/right side 3" 90 deg. Bent End Sidebar	4	1/2" x 2" Hex Bolts
2	Driver Front/ Passenger Rear Mounting Brackets	4	1/2" x 1-1/2" x 1/8" Flat Washers
2	Passenger Front/Driver Rear Mounting Brackets	4	1/2" Lock Washers
1	Driver/left side Front Support Bracket	12	8-1.25mm Nylon Lock Nuts
1	Passenger/right side Front Support Bracket	12	8mm x 24mm x 2mm Flat Washers
1	Driver/left side Rear Support Bracket		

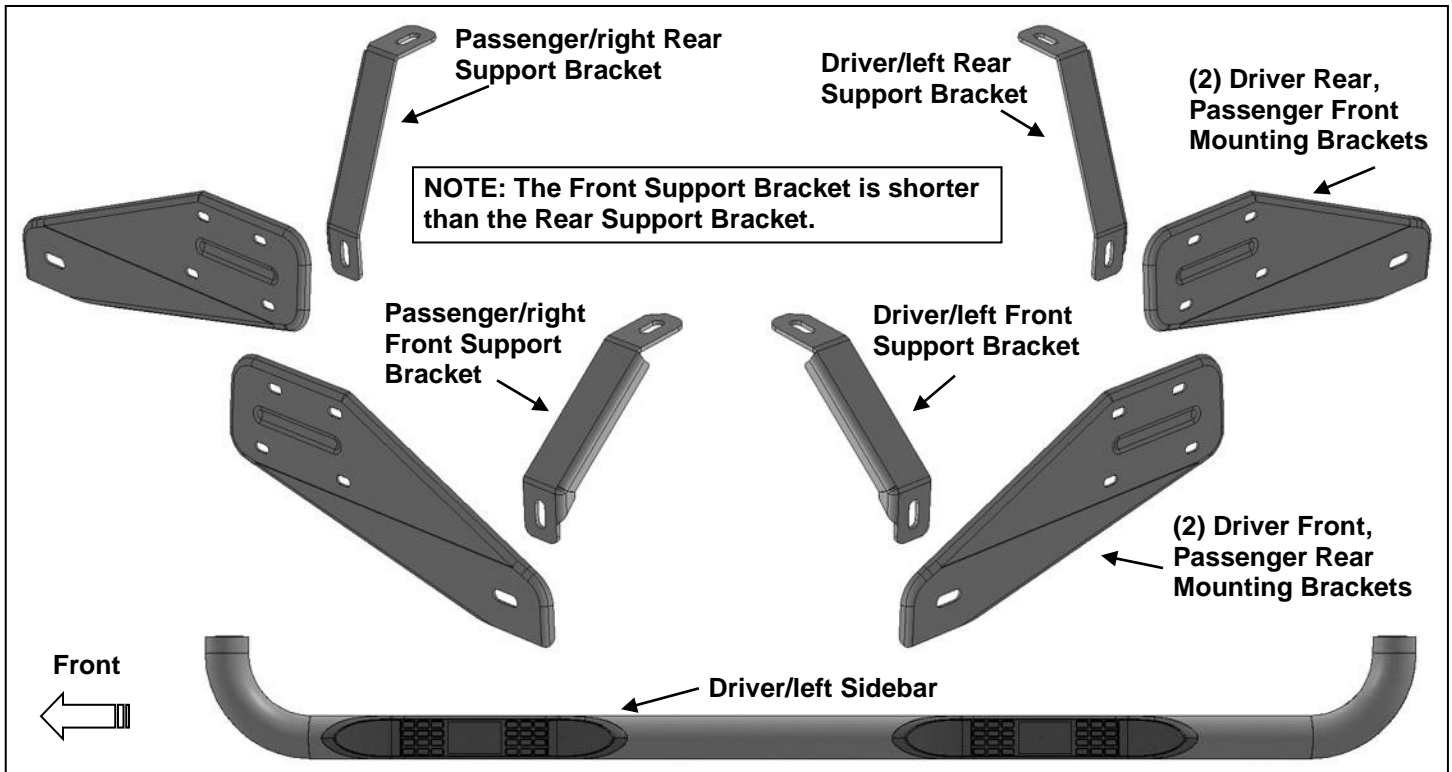

PROCEDURE:

REMOVE CONTENTS FROM BOX. VERIFY ALL PARTS ARE PRESENT. READ INSTRUCTIONS CAREFULLY BEFORE STARTING INSTALLATION. ASSISTANCE IS RECOMMENDED.

1. Start the installation under the driver/left side of the vehicle. Locate the front (3) factory studs along the inner side of the body panel, **(Figure 1)**. **IMPORTANT:** Use a wire brush or thread die to remove paint buildup from the threaded studs before continuing with installation.
2. Select (1) Driver/left Front Mounting Bracket, **(Figure 2)**. **NOTE:** Driver/left front and passenger/right rear Brackets are the same. Place the Bracket over the studs with the flat side against the body panel. Attach the Bracket to the (3) factory studs with (3) 8mm Flat Washers and (3) 8mm Nylon Lock Nuts, **(Figures 2 & 3)**. Leave Bracket loose at this time.
3. Locate the front body mount next to the installed Bracket, **(Figure 4)**. Remove the body bolt and washer, **(Figure 5)**. **NOTE:** Clean threads on body bolt to remove paint buildup before reinstalling.
4. Select the driver/left Front Support Bracket, **(Figure 6)**. Reuse the factory body bolt and washer to attach the upper slot in the Support Bracket to the body mount. **(Figures 7 & 8)**.
5. Move to the rear mounting location, **(Figure 9)**. Repeat **Steps 1—4** for Driver/left Rear Mounting Bracket and Driver/left Rear Support Bracket installation, **(Figures 10—12)**.
6. Carefully unwrap and select the Driver/left 3" Sidebar. Use the illustration above to help identify the correct Sidebar. With assistance, line up the front end of the tube with the front Bracket,

**3" 90 DEGREE BENT END SIDEBARS
2019 DODGE RAM 1500 CREW CAB**

(Figure 13). Attach the front end of the Sidebar to the Front Brackets with the included 1/2" Hex Bolt, 1/2" Lock Washer and 1/2" Flat Washer, (Figures 13 & 14). Do not tighten hardware.

7. Move to the rear of the Sidebar. Repeat **Step 6** to attach the Sidebar to the rear Brackets, (Figures 15 & 16).
8. Level and adjust the Sidebar as necessary and fully tighten all hardware.
9. Repeat **Steps 1—8** for passenger/right Bracket and Sidebar installation.
10. Do periodic inspections to the installation to make sure that all hardware is secure and tight.

To protect your investment, wax this product after installing. Regular waxing is recommended to add a protective layer over the finish. Do not use any type of polish or wax that may contain abrasives that could damage the finish. Mild soap may be used also to clean the Sidebar.

Driver/left Side Installation Pictured

(3) 8mm Flat Washers
(3) 8mm Nylon Lock Nuts

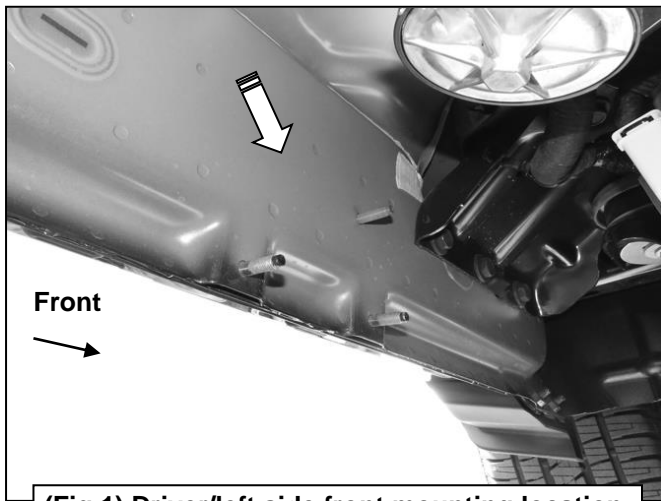

(Fig 1) Driver/left side front mounting location

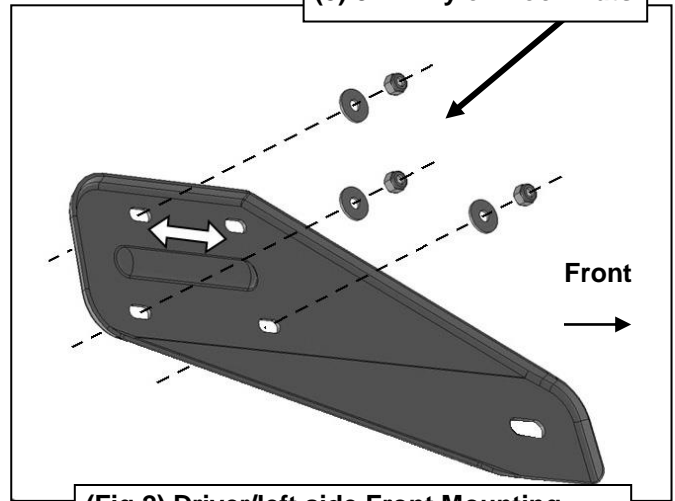

(Fig 2) Driver/left side Front Mounting Bracket attached to Side Panel illustrated

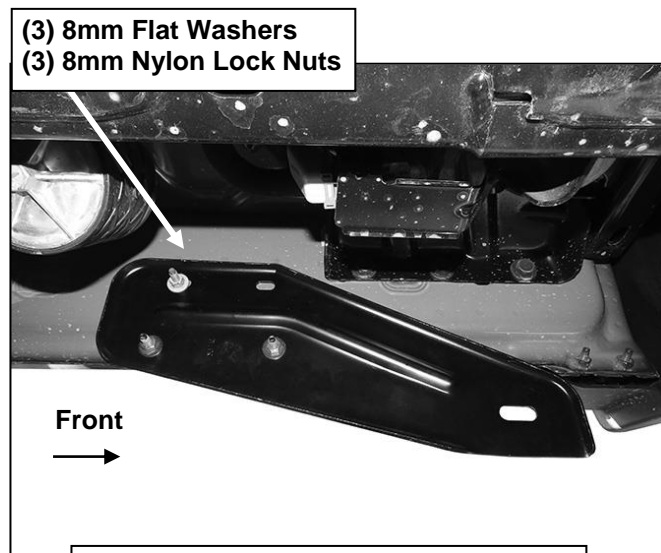

(Fig 3) Attach Bracket to the (3) studs



(Fig 4) Locate driver/left side front body mount

**3" 90 DEGREE BENT END SIDEBARS
2019 DODGE RAM 1500 CREW CAB**

Driver/left Side Installation Pictured

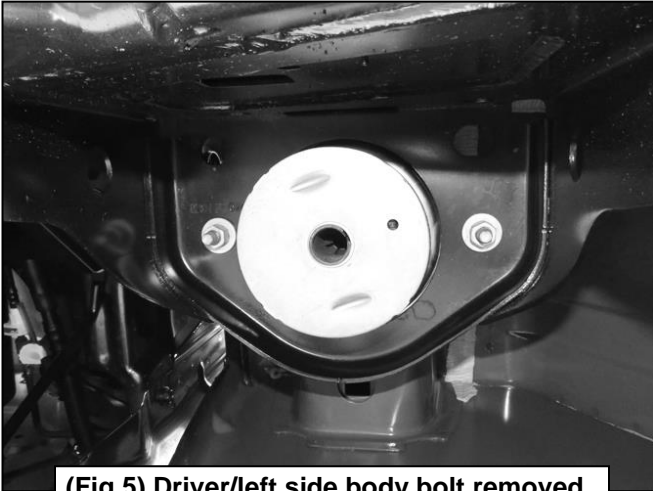

(Fig 5) Driver/left side body bolt removed



(Fig 6) Driver/left Front and Rear Support Brackets. NOTE: Front Support Bracket (left) is shorter than the rear (right).

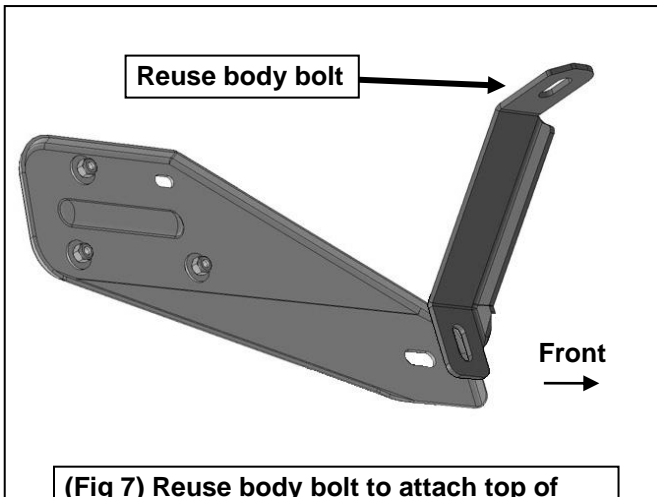

(Fig 7) Reuse body bolt to attach top of Support Bracket to body mount (Driver/left Front Support Bracket illustrated)



(Fig 8) Driver/left Front Support Bracket attached to body mount

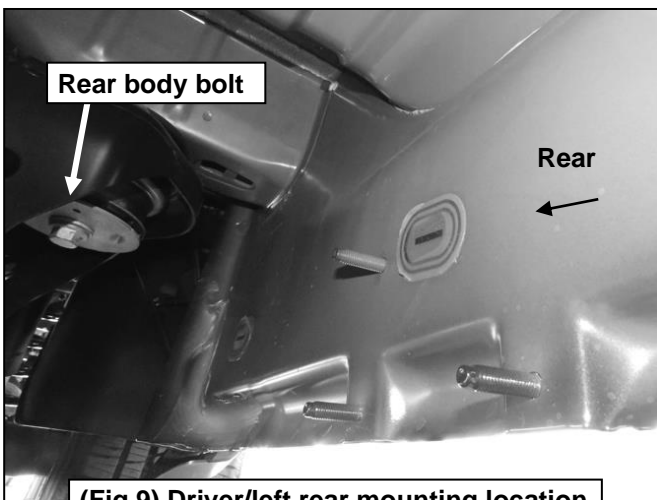

(Fig 9) Driver/left rear mounting location

**3" 90 DEGREE BENT END SIDEBARS
2019 DODGE RAM 1500 CREW CAB**

Driver/left Side Installation Pictured

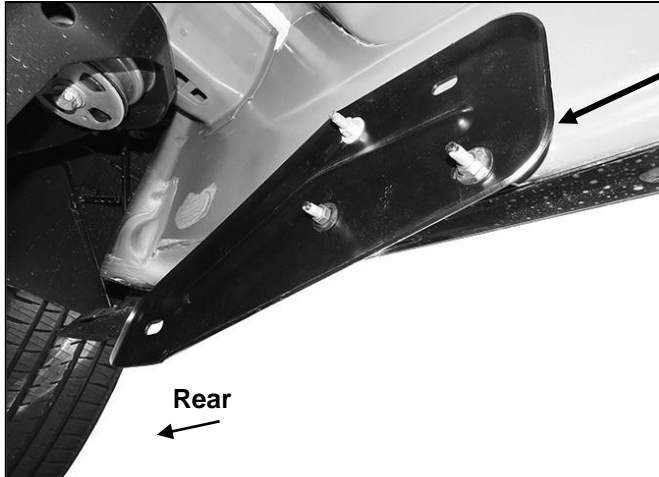

(3) 8mm Flat Washers
(3) 8mm Nylon Lock Nuts

(Fig 10) Driver/left Rear Mounting Bracket installed

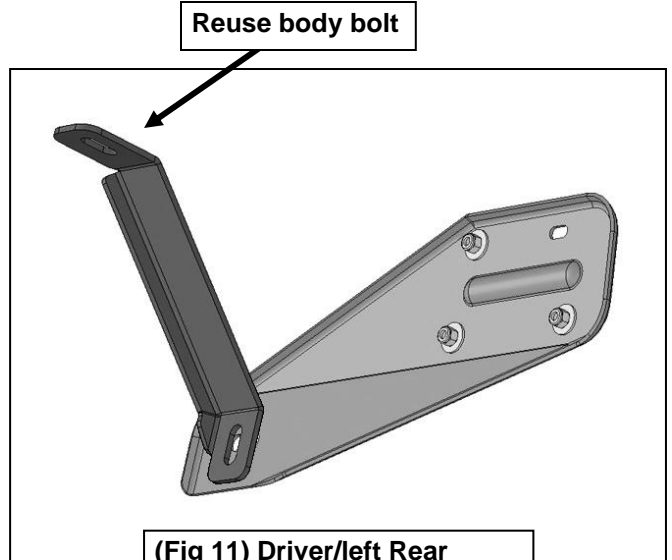

(Fig 11) Driver/left Rear Support Bracket illustrated

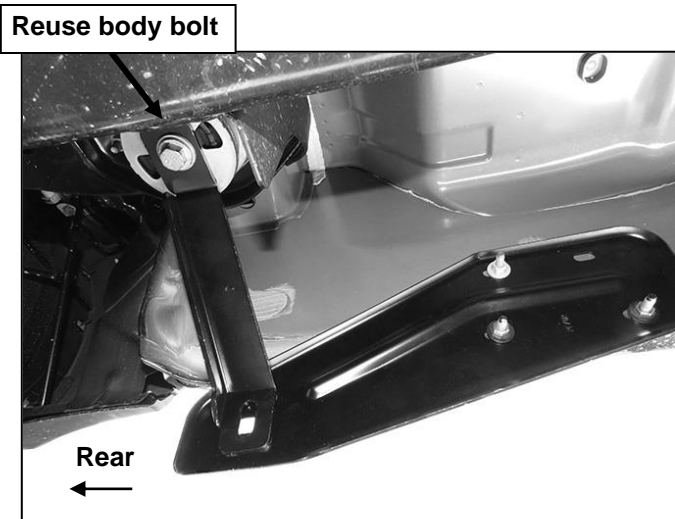

Reuse body bolt

(Fig 12) Reuse body bolt to attach top of Support Bracket to body mount (Driver/left Rear Brackets pictured)

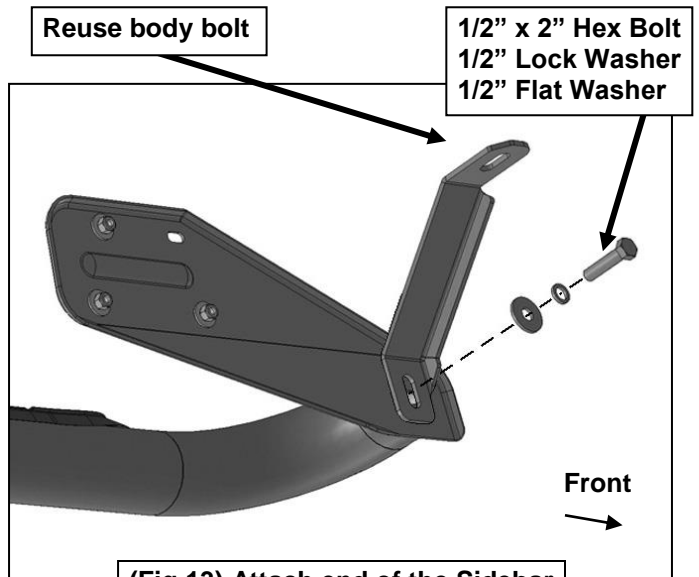

Reuse body bolt

1/2" x 2" Hex Bolt
1/2" Lock Washer
1/2" Flat Washer

(Fig 13) Attach end of the Sidebar to the driver/left front Brackets

**3" 90 DEGREE BENT END SIDEBARS
2019 DODGE RAM 1500 CREW CAB**

Driver/left Side Installation Pictured

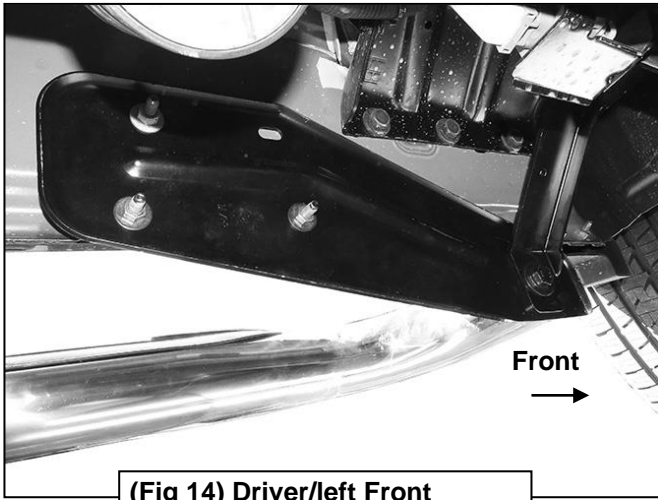

(Fig 14) Driver/left Front Brackets and Sidebar installed

- (2) 1/2" x 2" Hex Bolts
- (2) 1/2" Lock Washers
- (2) 1/2" Flat Washers

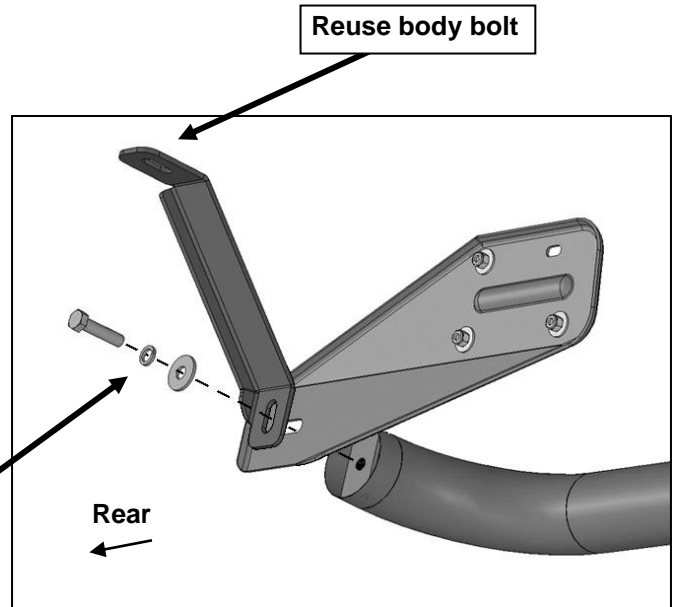

(Fig 15) Attach Sidebar to Driver/left Rear Brackets

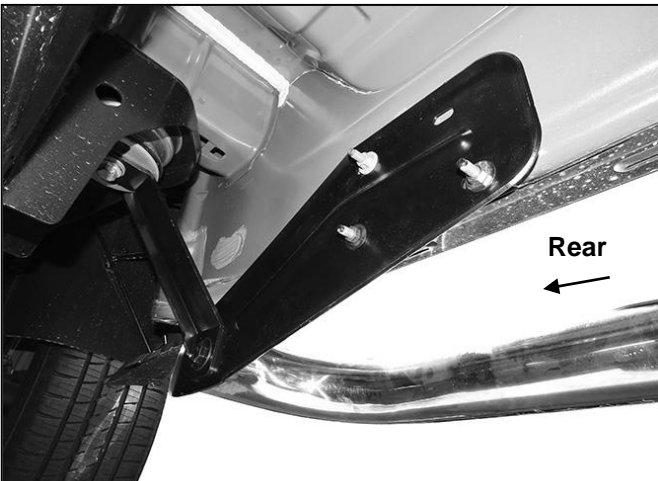

(Fig 16) Attach driver/left rear of Sidebar to Brackets



Complete Installation