

PARTS LIST:

Qty	Description	Qty	Description
2	Driver/Left Front and Center Brackets	16	8-1.25mm x 25mm Hex Bolts
2	Passenger/Right Front and Center Brackets	20	8mm x 24mm x 2mm Flat Washers
1	Driver/Left Rear Bracket	16	8mm Lock Washers
1	Passenger/Right Rear Bracket	4	8-1.25mm Hex Nuts
2	8-1.25mm x 30mm Bent Tab Bolt Plates	8	6-1.00 x 25mm Hex Bolts
2	8-1.25mm x 30mm Bolt Plates	16	6mm x 12mm x 1.6mm Flat Washers
1	8mm Insert Tool	8	6mm Lock Washers
2	8-1.25mm Threaded Insert	8	6mm Hex Nuts

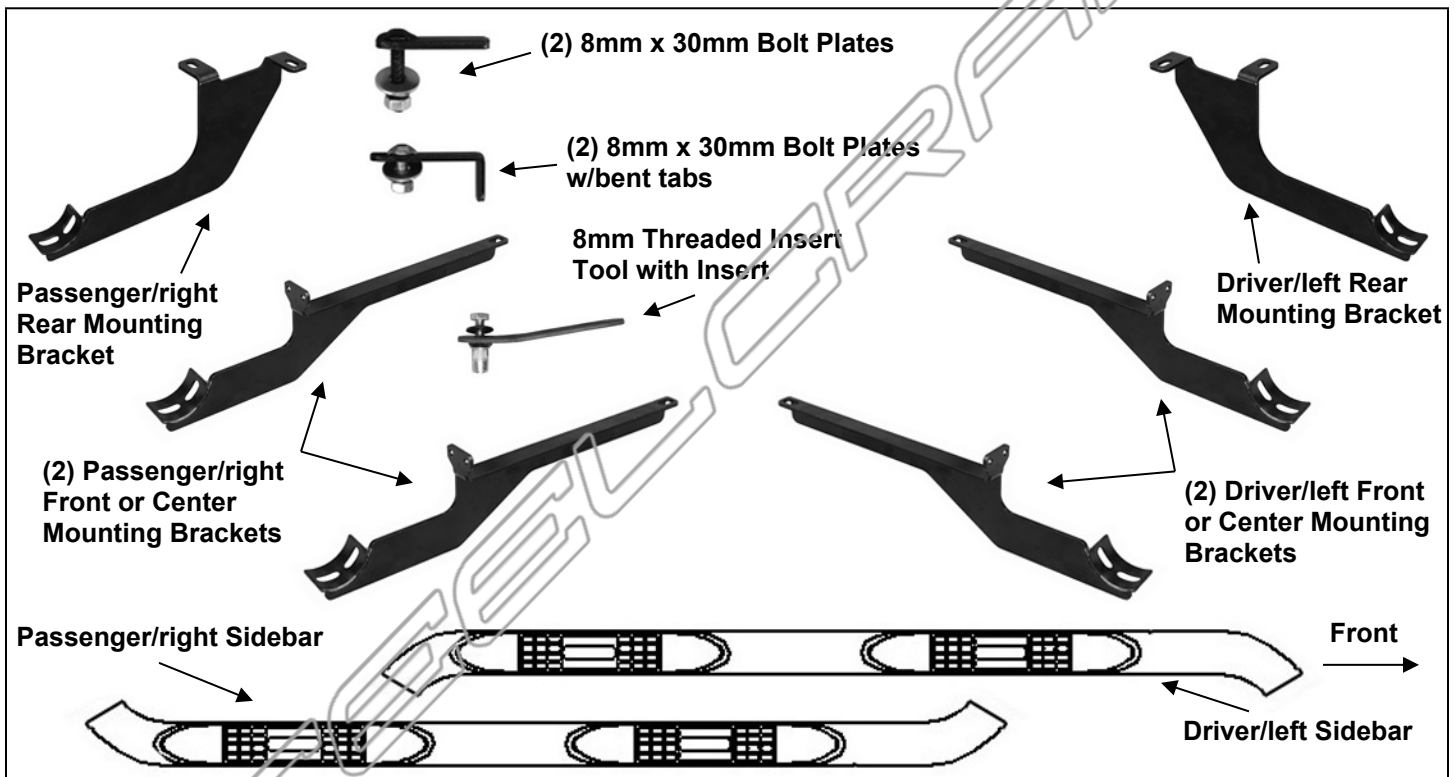

PROCEDURE:

1. REMOVE CONTENTS FROM BOX. VERIFY ALL PARTS ARE PRESENT. READ INSTRUCTIONS CAREFULLY BEFORE STARTING INSTALLATION. DRILLING/CUTTING IS REQUIRED.
2. Start installation on the passenger side of the vehicle. Remove the plastic rocker panel cover running from wheel opening to wheel opening, (Figure 1). NOTE: Removal of the rocker panel cover is not mandatory but it is highly recommended.
3. Locate the (2) factory hex bolts in the bottom of the inner frame rail, (Figure 1). Remove only the rear hex bolt if equipped, (Figure 2). Do not remove the front hex bolt.
4. Select (1) passenger side front/center Mounting Bracket, (Figure 3). NOTE: When properly installed, the mounting cradles on all (3) Sidebar Brackets will point toward the rear of the vehicle.
5. Attach the inner end of the Bracket to the frame rail with (1) 8mm Hex Bolt, (1) 8mm Lock Washer and (1) 8mm Flat Washer, (Figure 4). Line up the tab on the Bracket with the outside of the pinch weld. Use a clamp to temporarily attach the tab on the Bracket to the pinch weld.
6. Move toward the rear of the vehicle. Locate the factory holes in the bottom of the floor panel behind the jack point on the pinch weld directly in front of the rear suspension mount, (Figure 5). Select (1) 8mm Bolt Plate, (Figure 6A). Insert the Bolt Plate into the round hole in the inner floor panel, (Figure 6C).

- Select (1) 8mm Bolt Plate with Bent Tab, **(Figure 6B)**. Insert the Bolt Plate into the oval hole. Feed the threaded end of the Bolt Plate into and out of the smaller outer hole. **NOTE:** Hold the passenger side Rear Bracket up in place to help determine the correct mounting holes for the Bracket.
7. Select the passenger side Rear Bracket, **(Figure 7)**. Attach the Bracket to the (2) Bolt Plates with (2) 8mm Flat Washers, (2) 8mm Lock Washers and (2) 8mm Hex Nuts, **(Figure 8)**. Do not tighten hardware at this time.
 8. Select the passenger Sidebar. Temporarily attach the Sidebar to the front and rear Brackets with (4) 8mm Hex Bolts, (4) 8mm Lock Washers and (4) 8mm Flat Washers, **(Figure 9)**. Do not tighten hardware at this time. Line up the Sidebar with the front and rear of the vehicle. Once properly aligned, tighten the hardware and clamp attaching the mounting Brackets to the vehicle only.
 9. Move to the center of the vehicle. Locate the holes in the bottom of the inner frame rail, **(Figure 1)**. Locate the 6th hole back from the front bracket location. To help determine the correct mounting hole, hold the passenger front/center Bracket up in position against the threaded inserts in the bottom of the sidebar and the inner frame channel, **(Figure 9)**. **IMPORTANT:** Mark the correct mounting hole before moving to **Step 10, (Figure 10)**.
 10. Select (1) 8mm Hex Bolt, (1) 8mm Flat Washer, (1) 8mm Insert Tool and (1) 8mm Threaded Insert. Assemble the tool as pictured in **Figure 11**. Hold the Tool assembly and push the threaded Insert into the correct hole in the frame rail identified in **Step 9, (Figures 9 & 10)**. **IMPORTANT:** Threaded Insert cannot be removed once installed. Verify that Insert is in the correct hole in the frame rail before proceeding.
 11. Hold the Insert in place by firmly grasping the handle on the Tool. Turn the Hex Bolt, (tighten), with wrench to expand the Insert in the hole in the frame rail, **(Figures 12A & 12B)**. Once the Insert is fully compressed/expanded, remove the Hex Bolt and Tool from the Insert. **WARNING:** Do not over-tighten the Insert or damage to the part or Insert may result.
 12. Bolt the inner end of the center Bracket to the Insert with (1) 8mm Hex Bolt, (1) 8mm Lock Washer and (1) 8mm Flat Washer, **(Figure 13)**. Attach the outer end to the Sidebar with (2) 8mm Hex Bolts, (2) 8mm Lock Washers and (2) 8mm Flat Washers. Use a clamp to temporarily attach the outer end of the Bracket to the pinch weld to help hold up the Bracket as described in **Step 5, (Figure 13)**.
 13. Level and adjust the Sidebar to the vehicle. Once properly adjusted, mark the location of the front, **(Figure 14)**, and center, **(Figure 15)**, mounting tabs onto the outside of the pinch weld. **IMPORTANT:** Adjust the Sidebar height, (push upward), so that when level, the holes in the mounting tabs are not too close to the bottom edge of the pinch weld.
 14. Remove the Sidebar and loosen or remove the front and center Brackets. Use a 1/4" drill bit to drill out the (4) holes in the pinch weld for the front and center Brackets. Reinstall the front Bracket as previously described. Attach the outer end of the Bracket to the outside of the pinch weld with (2) 6mm Hex Bolts, (4) 6mm Flat Washers, (2) 6mm Lock Washers and (2) 6mm Hex Nuts, **(Figure 16)**.
 15. Repeat **Step 14** to install the center Mounting Bracket, **(Figure 17)**.
 16. Hold the plastic rocker panel cover up in position over the mounting tabs on the front and center Brackets, **(Figure 18)**. Apply removable tape, (masking tape for example), to the plastic cover. Mark the location of the mounting tabs onto the tape, not the cover. Use a sharp knife or hacksaw blade to carefully cut out a section of the cover to clear each mounting tab. **IMPORTANT:** Trim as little as possible to clear the mounting tab and hardware. **NOTE:** Primarily, the cover will need to be trimmed to clear the tab on the center mounting Bracket, **(Figure 18)**. The front of the cover may only need minor trimming to clear the tab, **(Figure 16)**. Reinstall the rocker cover with the factory hardware once properly clearanced.
 17. Reinstall the Sidebar as previously described.
 18. Adjust the Sidebar properly and tighten all hardware at this time.
 19. Repeat **Steps 2—18** for driver Sidebar installation.
 20. Do periodic inspections to the installation to make sure that all hardware is secure and tight.

To protect your investment, wax this product after installing. Regular waxing is recommended to add a protective layer over the finish. Do not use any type of polish or wax that may contain abrasives that could damage the finish.

For stainless steel: Aluminum polish may be used to polish small scratches and scuffs on the finish. Mild soap may be used also to clean the Sidebar.

For gloss black finishes: Mild soap may be used to clean the Sidebar.

Passenger Side Installation Pictured

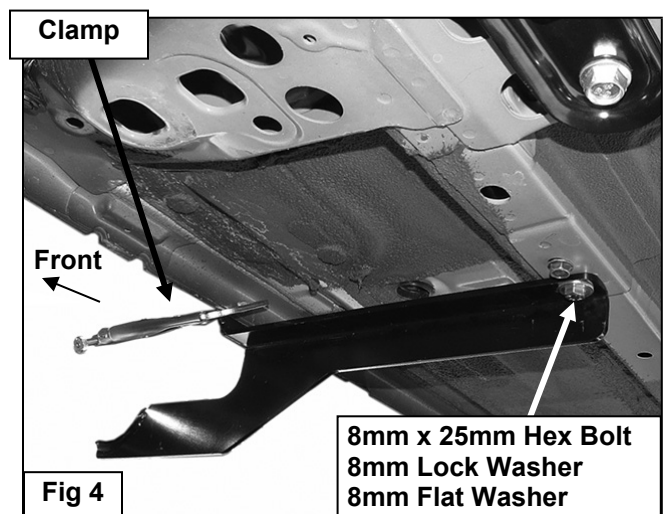
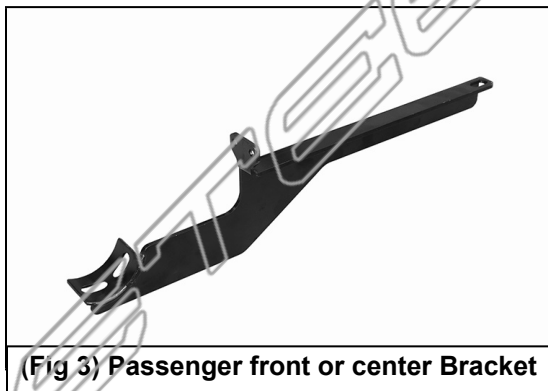
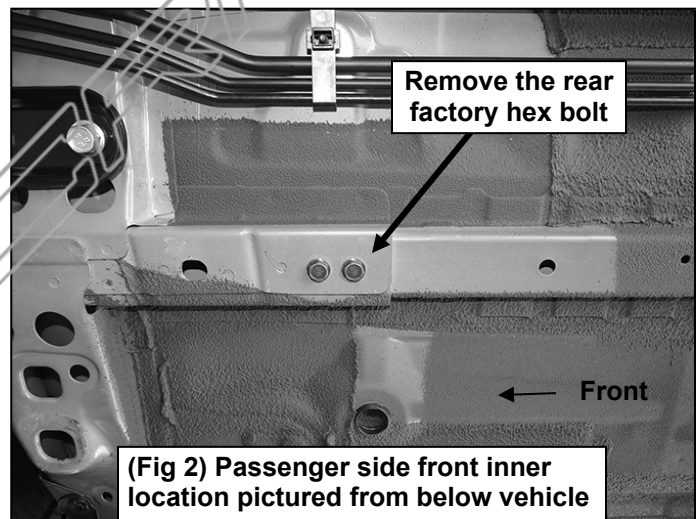
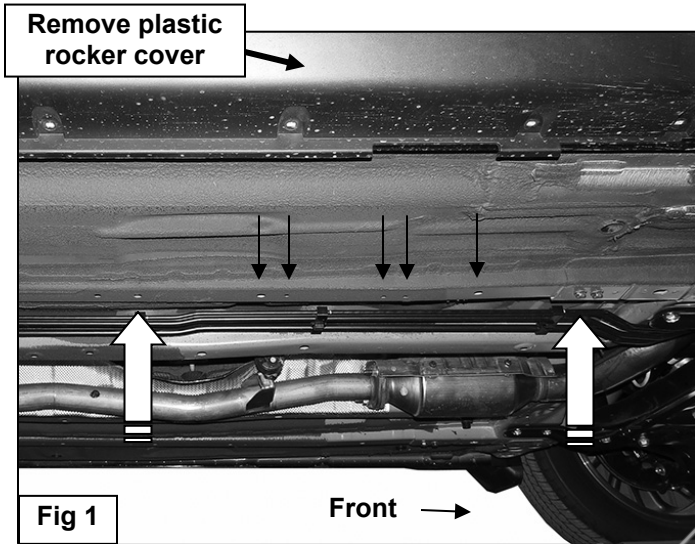

Passenger Side Installation Pictured

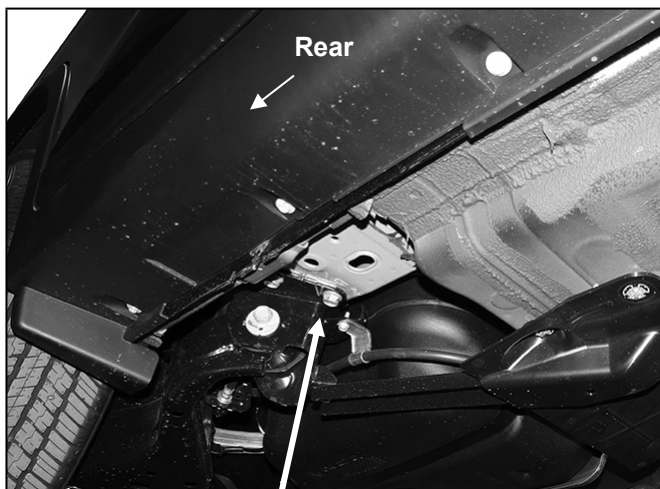

(Fig 5) Passenger side rear mounting location

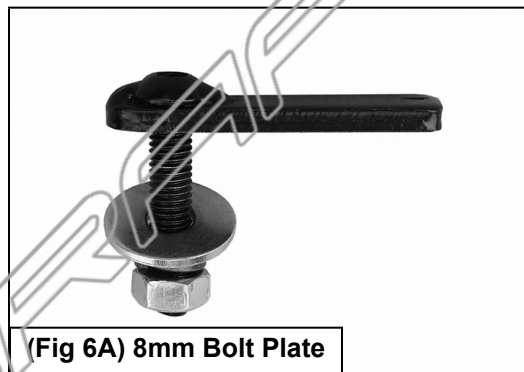

(Fig 6A) 8mm Bolt Plate



(Fig 6B) 8mm Bolt Plate with tab

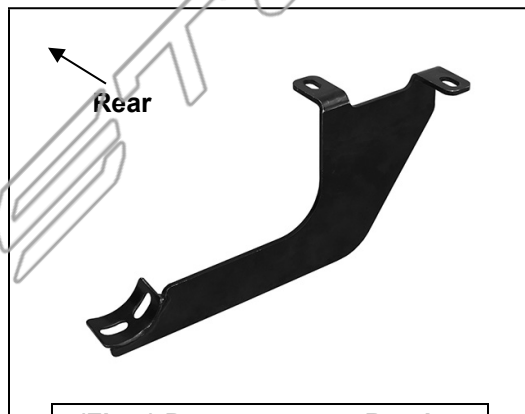

(Fig 7) Passenger rear Bracket

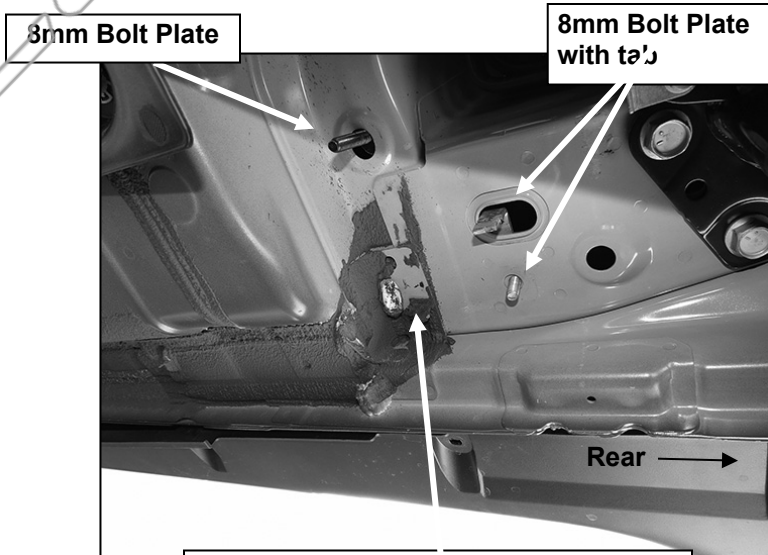

(Fig 6C) Passenger rear mounting location pictured from below. Scrape off excess sealant from mounting location before installing rear Bracket

Passenger Side Installation Pictured

- (2) 8mm Flat Washers
- (2) 8mm Lock Washers
- (2) 8mm Hex Nuts



(Fig 8) Passenger side rear Bracket pictured from below vehicle

- 8mm x 25mm Hex Bolt
- 8mm Lock Washer
- 8mm Flat Washer

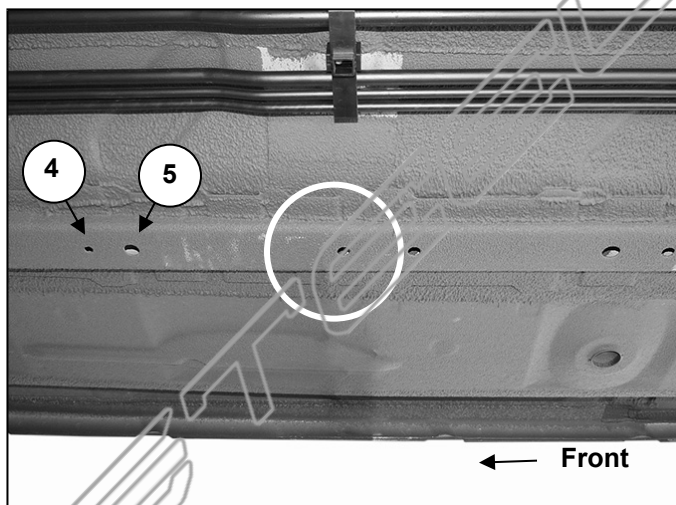
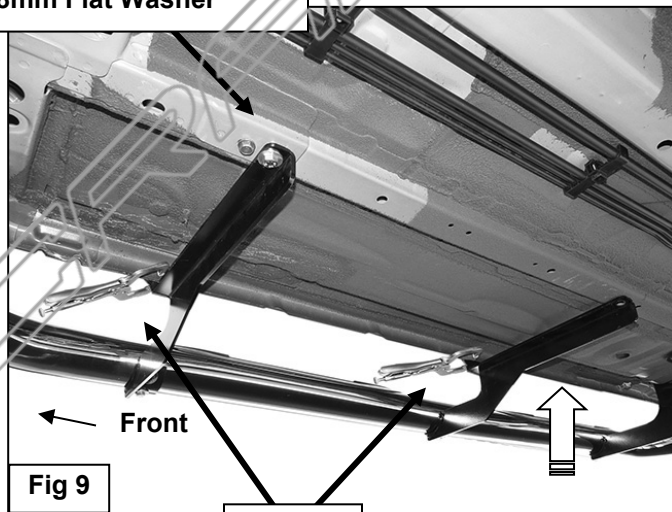

(Fig 10) Locate the 6th hole along the bottom of the frame rail

8mm Threaded Insert

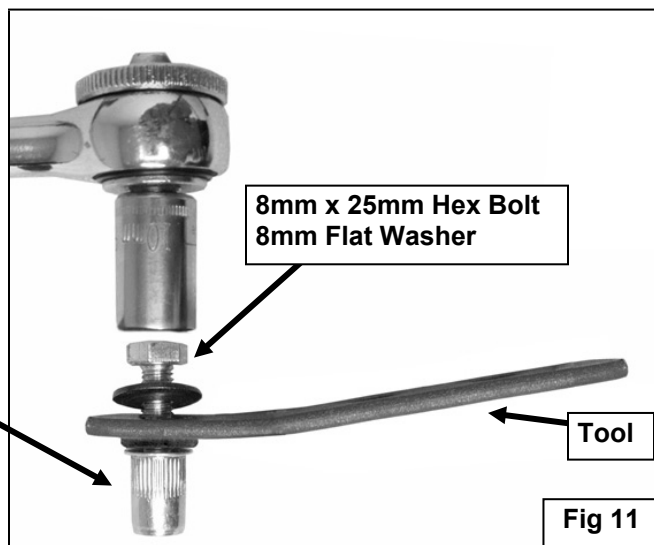

Passenger Side Installation Pictured

8mm Threaded Insert

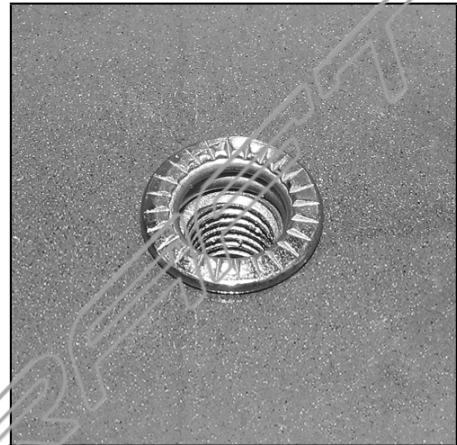
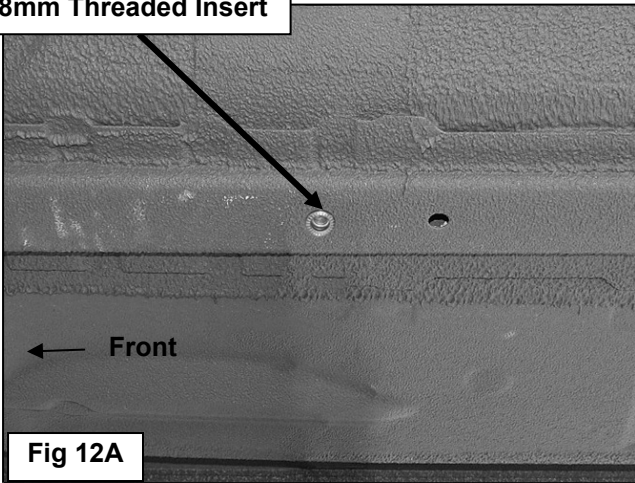

(Fig 12B) Insert fully installed

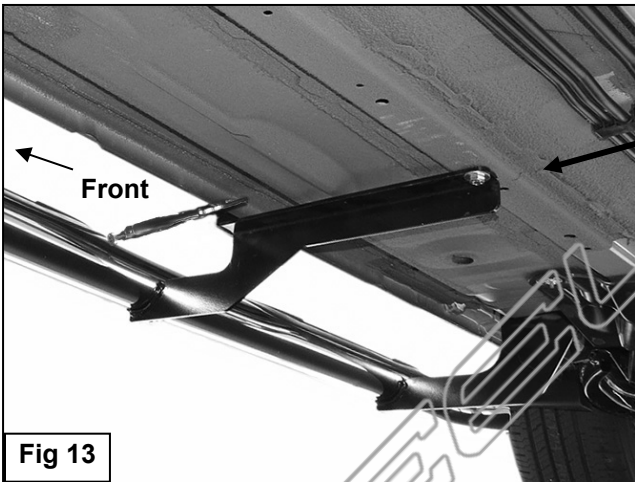

8mm x 25mm Hex Bolt
8mm Lock Washer
8mm Flat Washer



(Fig 14) Passenger front Bracket location marked before drilling

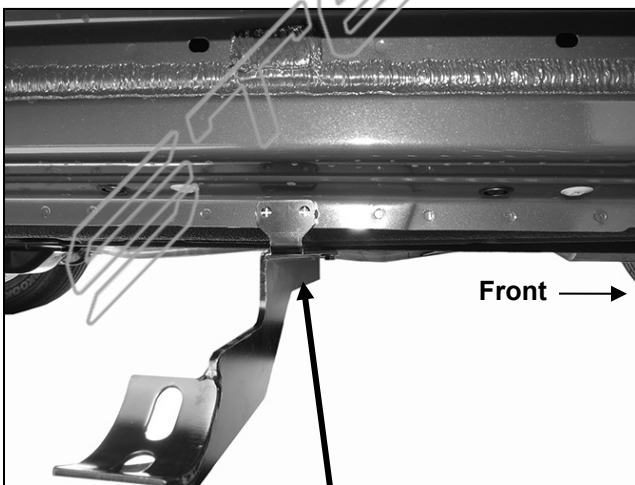

(Fig 15) Passenger center Bracket location marked before drilling

Passenger Side Installation Pictured

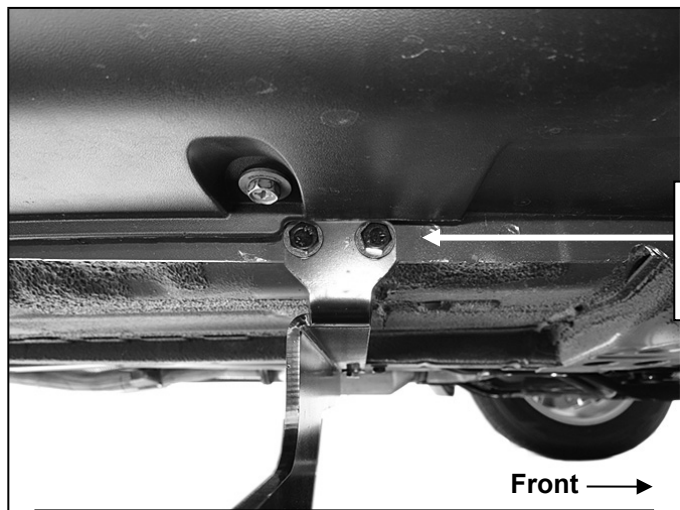

- (2) 6mm x 25mm Hex Bolts
- (4) 6mm Flat Washer
- (2) 6mm Lock Washer
- (2) 6mm Hex Nuts

(Fig 16) Passenger side front Bracket pictured

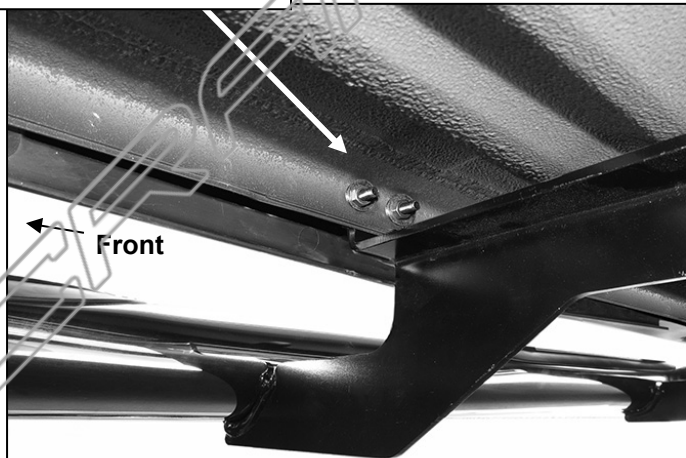

(Fig 17) Passenger side center Bracket pictured

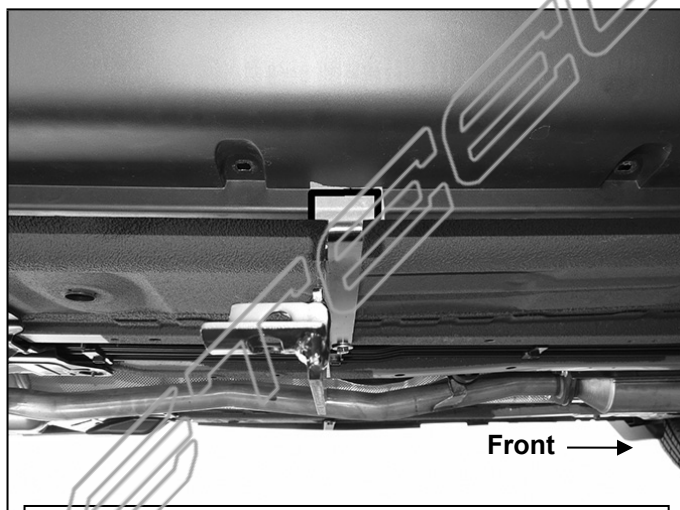

(Fig 18) Passenger side center Bracket pictured. Trim cover to clear Bracket after all Brackets have been lined up and installed. Marks indicating area to cut are for example only

