

# **INSTALLATION INSTRUCTIONS**

**4X SERIES 4" BENT END SIDE STEPS**

**09-14 FORD F-150 SUPER CREW CAB**

STEELCRAFT

**PARTS LIST:**

1	Driver/Left Side Bar	10	8-1.25mm x 30mm Hex Bolts
1	Passenger/Right Side Bar	10	8-1.25mm x 25mm Hex Bolts
2	Driver/Left Front-Passenger/Right Rear Brackets	10	8mm x 28mm OD x 3mm Large Flat Washers
2	Passenger/Right Front-Driver/Left Rear Brackets	20	8mm x 24mm OD x 2mm STD Flat Washers
1	Driver/Left Center Mounting Bracket	20	8mm Lock Washers
1	Passenger/Right Center Mounting Bracket	10	8mm Hex Nuts
10	8mm Deep Clip Nuts	12	8mm x 25mm Combo Bolts

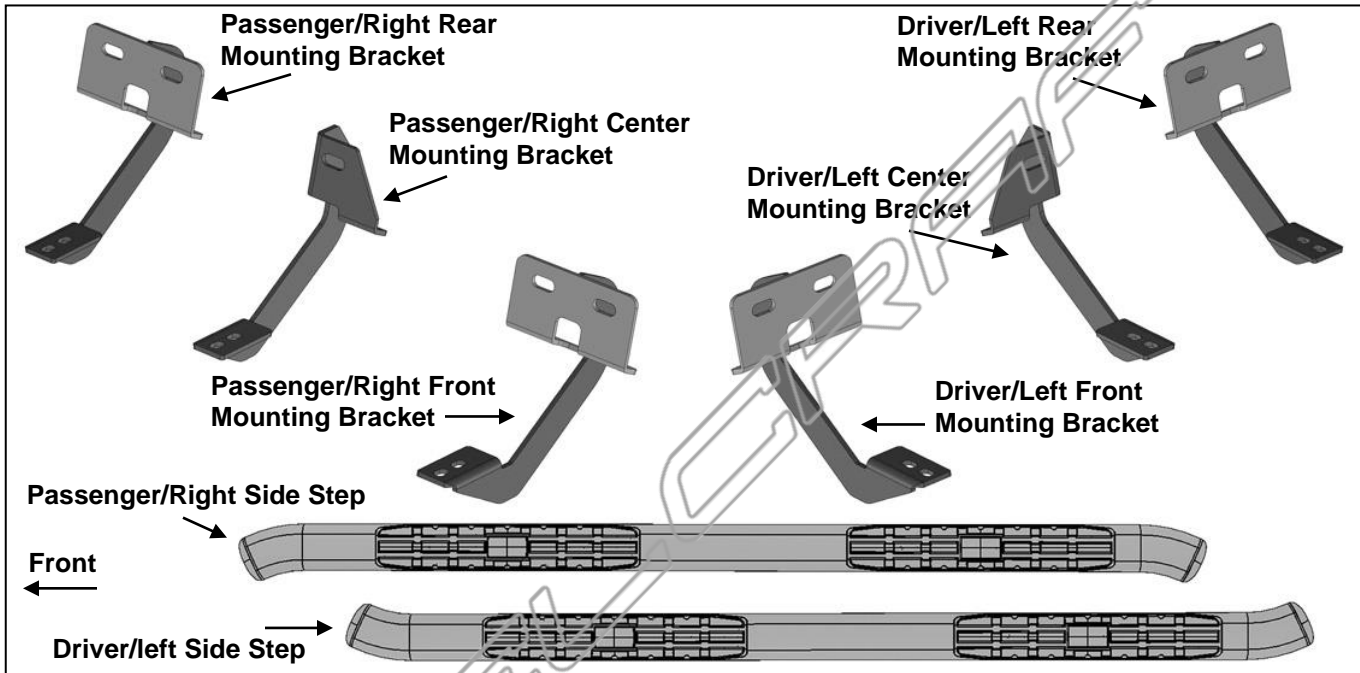

**PROCEDURE:**

- REMOVE CONTENTS FROM BOX. VERIFY ALL PARTS ARE PRESENT. READ INSTRUCTIONS CAREFULLY BEFORE STARTING INSTALLATION.**
- Starting on the passenger side of the vehicle, locate the (2) holes in the bottom of the body panel, (pinch weld), toward the front tire. Next, locate the rectangular opening and (2) small holes in the inner body panel directly above the holes in the pinch weld, **(Figure 1)**. **NOTE:** The holes in the inner panel may be covered with sealing tape or insulation.
- Slide (1) 8mm Clip Nut into the rectangular opening with the nut towards the inside. Line up the threaded nut on the clip with the round hole, **(Figure 1)**. Repeat to install the 2nd 8mm Clip Nut in remaining hole location.
- Select the passenger side front Bracket, **(Figure 2)**. Attach the top mounting holes in the Bracket to the (2) Clip Nuts with the included (2) 8mm x 30mm Hex Bolts, (2) 8mm Lock Washers and (2) 8mm x 28mm Large Flat Washers, **(Figure 3)**. Do not tighten hardware at this time. **NOTE:** The cradle on the front Bracket will face to the rear of the vehicle.
- Align the bottom holes in the front Bracket with the (2) holes in the pinch weld. Bolt the Bracket to the pinch weld with the included (2) 8mm x 25mm Hex Bolts, (4) 8mm STD Flat Washers, (2) 8mm Lock Washers and (2) 8mm Hex Nuts, **(Figure 3)**. **NOTE:** Insert the bolts up from the bottom of the pinch weld and through the Bracket.
- Select the driver side center Mounting Bracket, **(Figure 4)**. Move toward the center of the vehicle. Locate the (2) holes in the pinch weld similar to the front location, **(Figure 5)**. Insert (1) 8mm Clip Nut into the rectangular opening and up to the single small round hole in the body panel. Attach the top of the center Bracket to the Clip Nut with (1) 8mm x 30mm Hex Bolt, (1) 8mm Lock Washer and (1) 8mm x 28mm Large Flat Washer, **(Figure 6)**. Line up the hole in the Bracket with the forward hole in the pinch weld. Bolt the Bracket to the pinch weld with (1) 8mm x 25mm Hex Bolt, (2) 8mm STD Flat Washers, (1) 8mm Lock Washer and (1) 8mm Hex Nut, **(Figure 6)**. Do not tighten hardware at this time. **NOTE:** The cradle on the center mounting Bracket will face the front of the vehicle.

7. Select the passenger side rear mounting Bracket, **(Figure 7)**. Continue along the cab to the rear mounting location, **(Figure 1)**. Locate the last (2) mounting holes in the pinch weld towards the back of the cab. Repeat **Steps 2—5** for rear mounting Bracket installation. **NOTE:** The cradle on the rear Bracket will face the front of the vehicle, **(Figure 8)**.
8. Carefully position the Side Step onto the mounting Brackets. Attach the Side Step to the Brackets with the included (6) 8mm x 25mm Combination Bolts, **(Figure 8)**. Do not tighten hardware at this time.
9. Level and adjust the Side Step properly and tighten all hardware.
10. Repeat **Steps 2—9** for driver/left Side Step installation.
11. Do periodic inspections to the installation to make sure that all hardware is secure and tight.

**To protect your investment**, wax this product after installing. Regular waxing is recommended to add a protective layer over the finish. Do not use any type of polish or wax that may contain abrasives that could damage the finish.

**For stainless steel:** Aluminum polish may be used to polish small scratches and scuffs on the finish. Mild soap may be used also to clean the Side Step.

**For gloss black finishes:** Mild soap may be used to clean the Side Step.

### Passenger Side Installation Pictured

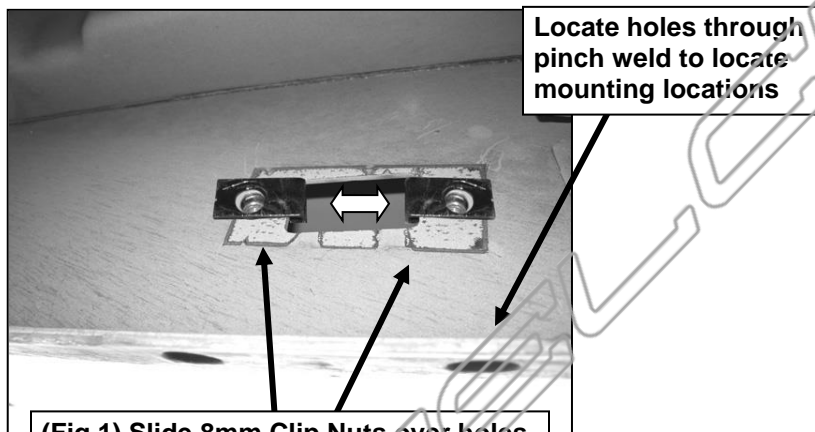

**(Fig 1)** Slide 8mm Clip Nuts over holes

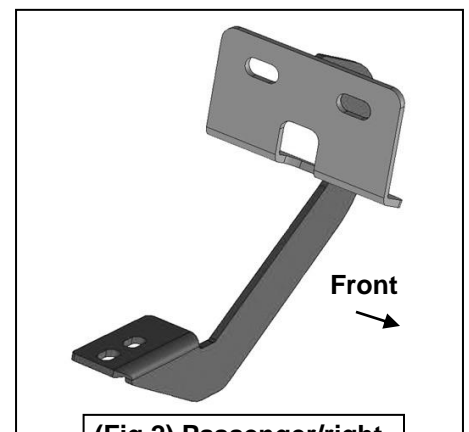

**(Fig 2)** Passenger/right front mounting Bracket

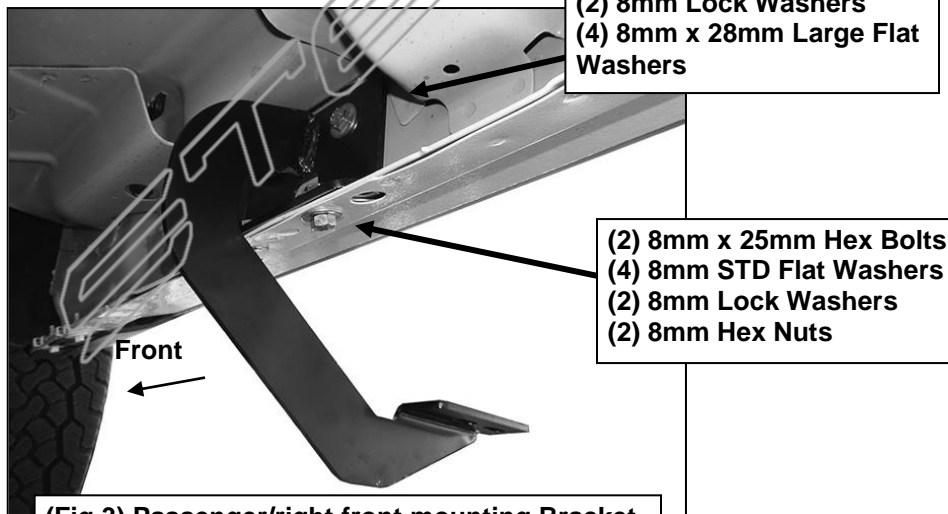

**(Fig 3)** Passenger/right front mounting Bracket

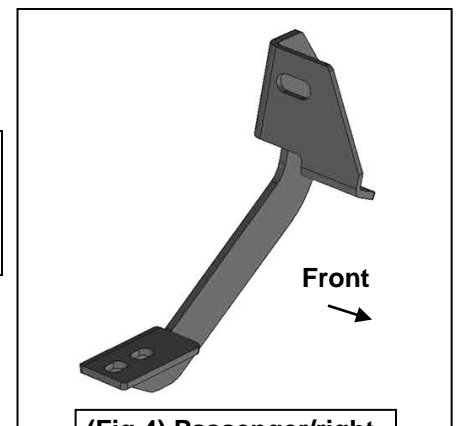

**(Fig 4)** Passenger/right front mounting Bracket

Passenger Side Installation Pictured

