

Parts List:

1	Driver/left side PNC Sidebar	2	Passenger/right side Center & Rear Support Brackets
1	Passenger/right side PNC Sidebar	6	10-1.5mm x 30mm Hex Bolts
1	Driver/left side Front Mounting Bracket	12	10mm x 24mm x 2mm Flat Washers
1	Passenger/right side Front Mounting Bracket	6	10-1.5mm Nylon Lock Nuts
1	Driver/left side Center Mounting Bracket	12	8-1.25mm Combo Bolts
1	Passenger/right side Center Mounting Bracket	6	8-1.25mm x 35mm Hex Bolts
1	Driver/right side Rear Mounting Bracket	6	8mm x 28mm x 3mm Flat Washers
1	Passenger/right side Rear Bracket	6	8mm Lock Washers
1	Driver/left side Front Support Bracket	12	6-1.0mm x 25mm Hex Bolts
1	Passenger/right side Front Support Bracket	24	6mm x 22mm x 2mm Flat Washers
2	Driver/left side Center and Rear Support Brackets	12	6-1.0mm Nylon Lock Nuts

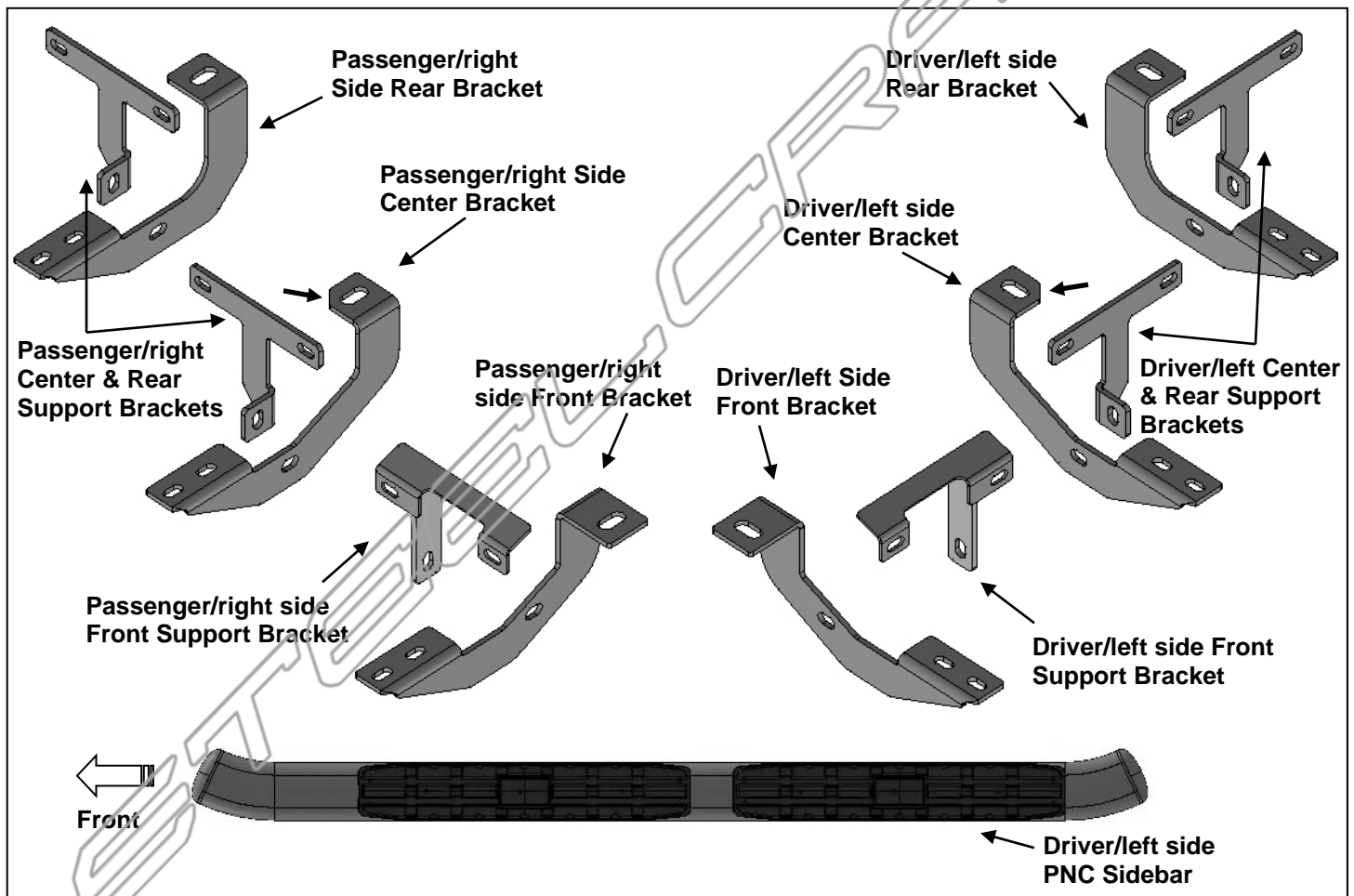

PROCEDURE:

1. REMOVE CONTENTS FROM BOX. VERIFY ALL PARTS ARE PRESENT. READ INSTRUCTIONS CAREFULLY BEFORE STARTING INSTALLATION. FACTORY INSTALLED OR AFTERMARKET "ROCK RAILS," SIDE STEPS OR RUNNING BOARDS MUST BE REMOVED.
2. Start installation toward the front of the passenger side of the vehicle and find the front threaded insert located in between the first pair of holes along the pinch weld, **(Figure 1)**.
3. Select the Passenger/right side Front Mounting Bracket, **(Figure 2)**. **IMPORTANT:** Use the illustration above and **Figure 3** to properly identify the Mounting Bracket. Attach the Bracket to the threaded insert

- using (1) 8mm Hex Bolt, (1) 8mm Lock Washer and (1) 8mm Flat Washer, **(Figure 3)**. Do not tighten hardware at this time.
- Next, select the Passenger/right side Front Support Bracket, **(Figure 4)**. **IMPORTANT:** Use the illustration above to help identify the correct Support Bracket. Align the Bracket to the **back** of the pinch weld and to the **rear** side of the Front Mounting Bracket. Attach the Support Bracket to the pinch weld using (2) 6mm Hex Bolts, (4) 6mm Flat Washers and (2) 6mm Nylon Lock Nuts, **(Figures 4—6)**. **NOTE:** Insert bolts from the outside of the pinch weld and through the Bracket. Use (1) 10mm Hex Bolt, (2) 10mm Flat Washers and (1) 10mm Nylon Lock Nut to secure the Support Bracket to the Mounting Bracket, **(Figures 5 & 6)**. Do not tighten hardware at this time.
 - Move along the body panel to the center mounting location and locate the threaded insert and pair of holes on the pinch weld, **(Figure 7)**. Repeat **Steps 3 & 4** to install the Center Brackets, **(Figures 9 & 10)**. **NOTE:** The Center and Rear Mounting Brackets look similar but each one is unique. Notice the bottom corner trim on the Center Mounting Bracket in the illustration above and **Figure 8**.
 - Move to the last, rear, mounting location and locate the threaded insert and pair of holes on the pinch weld, **(Figure 11)**. Repeat **Steps 3 & 4** to install the Rear Brackets, **(Figures 12 & 13)**. **NOTE:** The Center and Rear Mounting Brackets look similar but each one is unique. Notice the rounded corners on the Rear Mounting Bracket in the illustration above and **Figure 8**.
 - Select the Passenger/Right Sidebar. Use the illustration above to help identify the correct Sidebar for each side. Carefully position the Sidebar onto the (3) Mounting Brackets. **IMPORTANT:** Do not slide, (front to back or rotate), the Sidebar on the Brackets or damage to the finish on the Sidebar may result. Attach the Sidebar to the Mounting Brackets with (6) 8mm x 25mm Combination Hex Bolts, **(Figures 14—16)**. Do not tighten hardware. **NOTE:** Mounting cradles on Brackets should be inline and pointing toward the rear of the vehicle for proper installation. Snug all hardware but do not tighten.
 - Level and adjust the Sidebar and tighten all hardware.
 - Repeat **Steps 1—8** for driver/left Sidebar installation.
 - Do periodic inspections to the installation to make sure that all hardware is secure and tight.

To protect your investment, wax this product after installing. Regular waxing is recommended to add a protective layer over the finish. Do not use any type of polish or wax that may contain abrasives that could damage the finish. Mild soap may be used to clean Sidebar.

Passenger Side Installation Pictured

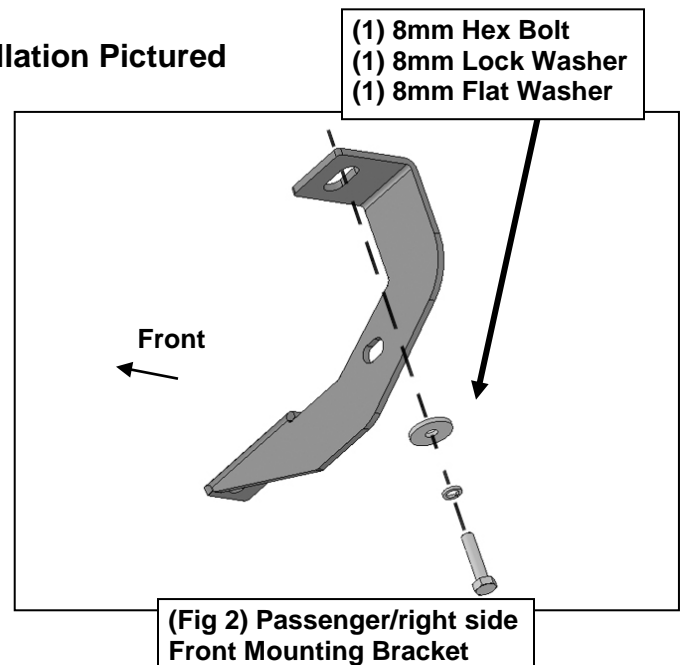
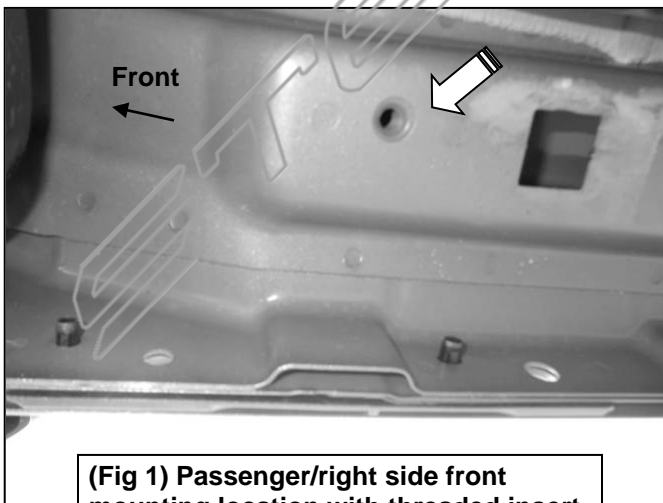

Passenger Side Installation Pictured

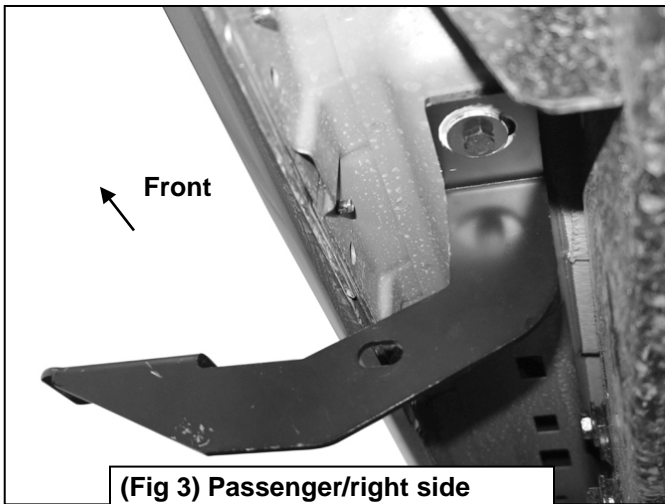

(Fig 3) Passenger/right side Front Mounting Bracket installed

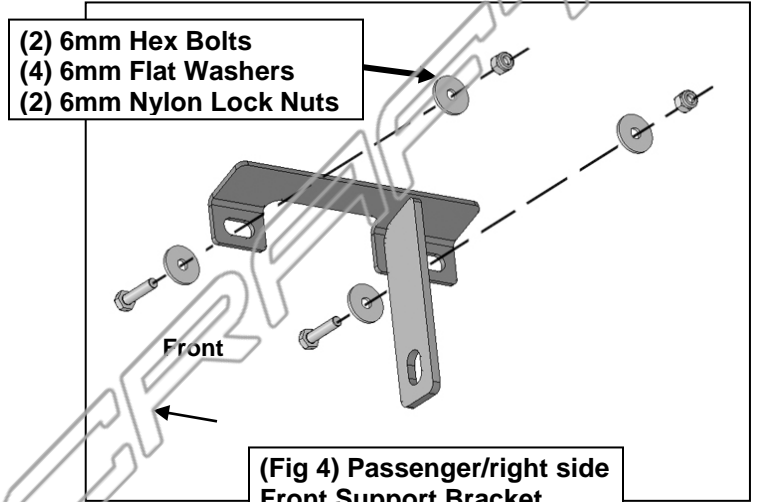

(Fig 4) Passenger/right side Front Support Bracket

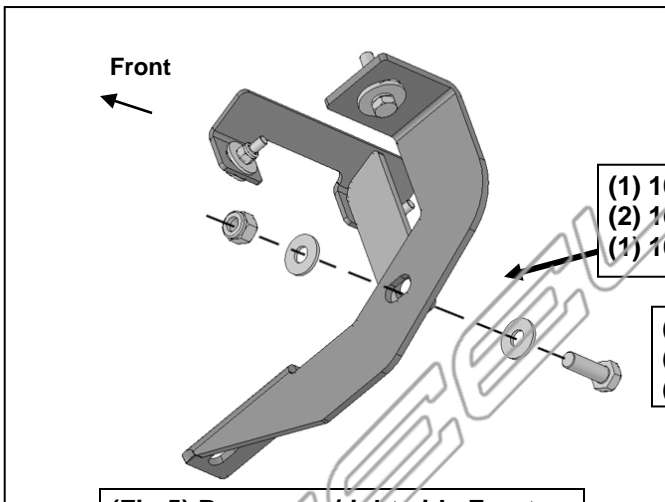

(Fig 5) Passenger/right side Front Bracket attached to Support Bracket

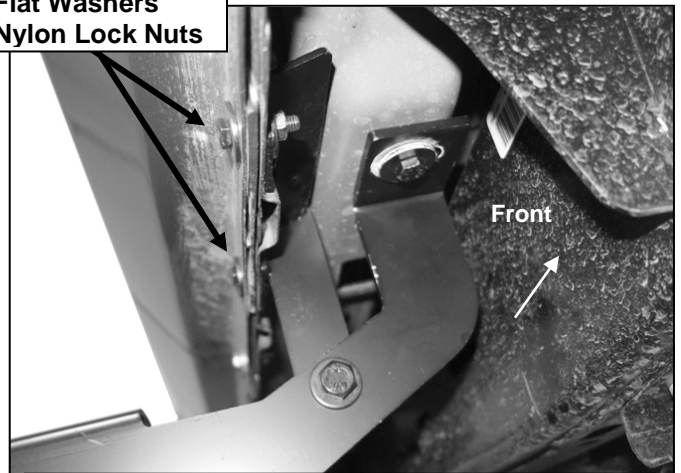

(Fig 6) Attach Support Bracket to back of pinch weld and to rear side of Mounting Bracket

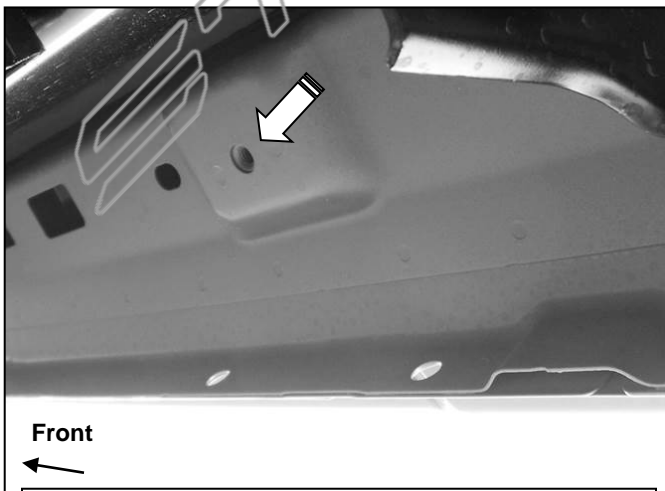

(Fig 7) Passenger side center mounting location

Passenger Side Installation Pictured

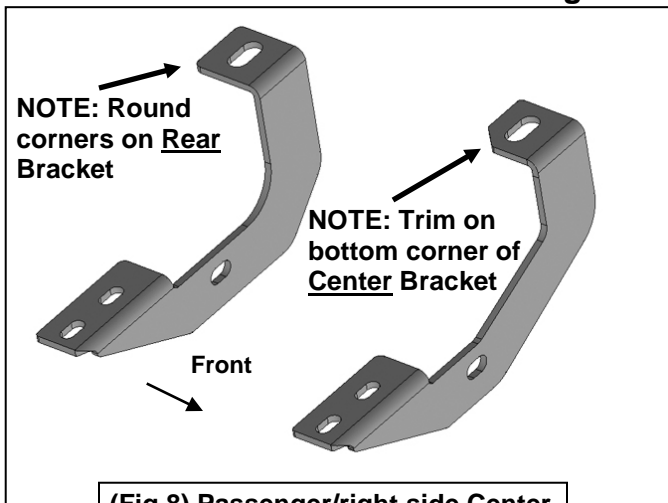

(Fig 8) Passenger/right side Center & Rear Mounting Brackets

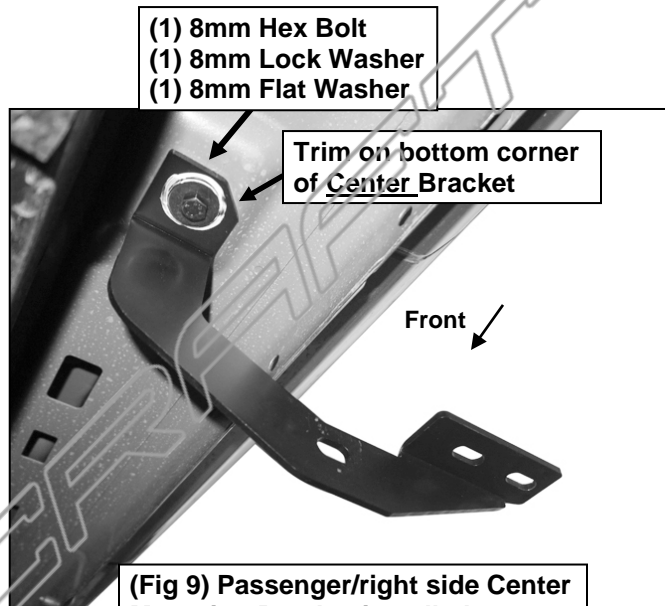

(Fig 9) Passenger/right side Center Mounting Bracket installed

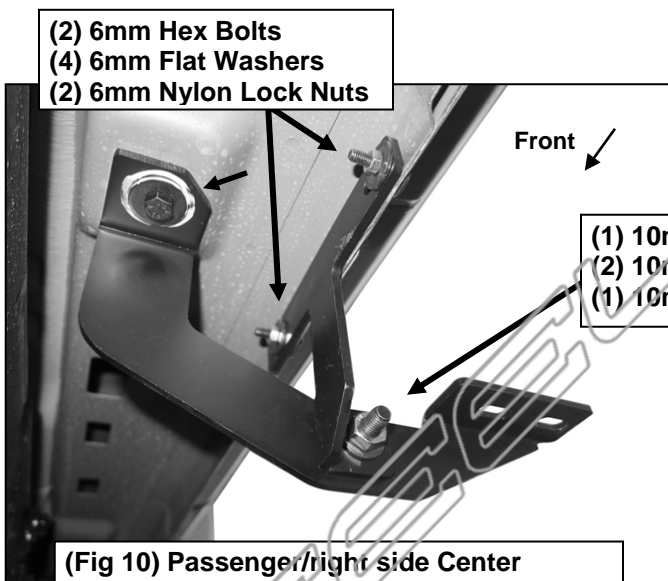

(Fig 10) Passenger/right side Center Bracket attached to Center Support

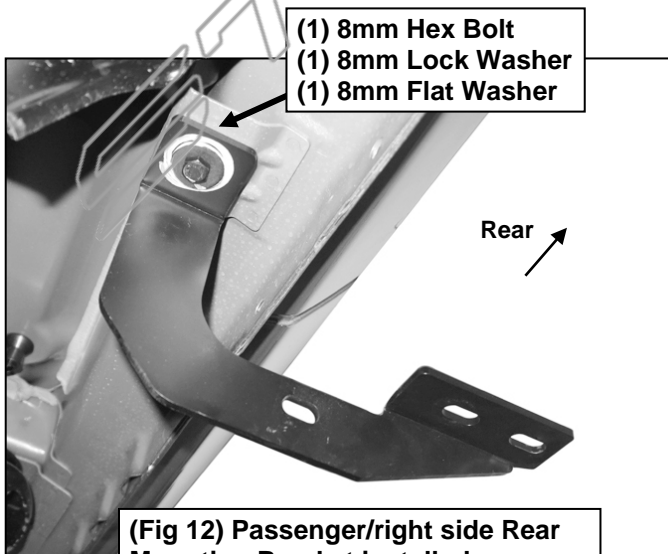

(Fig 12) Passenger/right side Rear Mounting Bracket installed

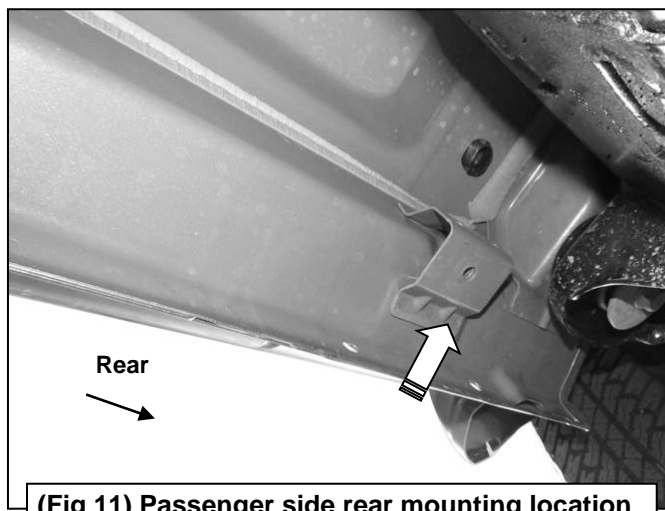

(Fig 11) Passenger side rear mounting location

Passenger Side Installation Pictured

- (2) 6mm Hex Bolts
- (4) 6mm Flat Washers
- (2) 6mm Nylon Lock Nuts

- (1) 10mm Hex Bolt
- (2) 10mm Flat Washers
- (1) 10mm Nylon Lock Nut

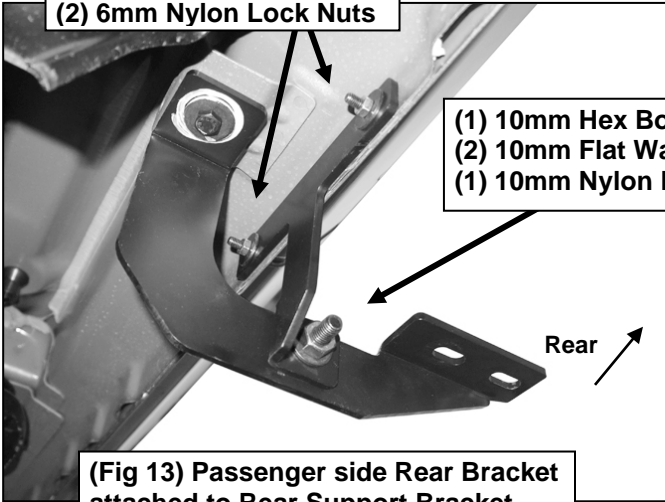

(Fig 13) Passenger side Rear Bracket attached to Rear Support Bracket

- (2) 8mm x 25mm Combo Bolts

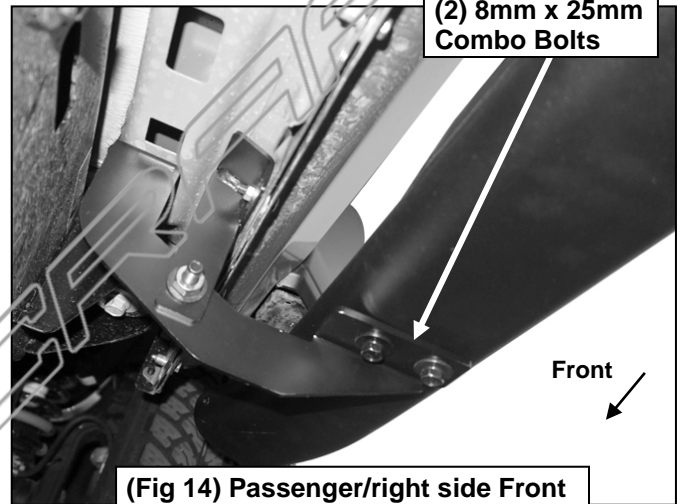

(Fig 14) Passenger/right side Front Brackets attached to PNC Sidebar

Trim on bottom corner of Center Bracket

Front

- (2) 8mm x 25mm Combo Bolts

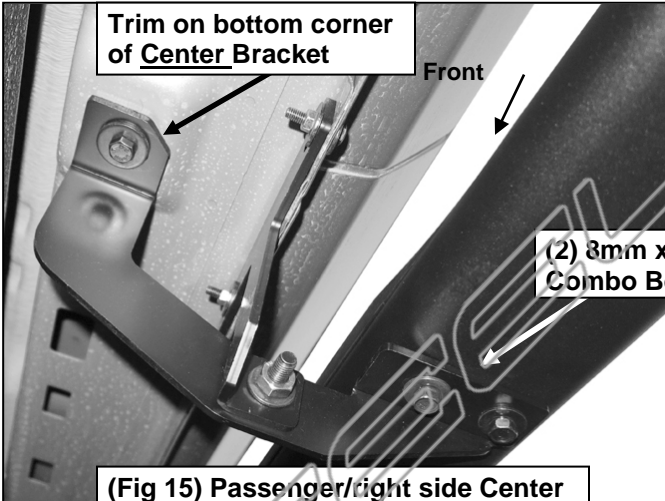

(Fig 15) Passenger/right side Center Brackets attached to PNC Sidebar

Rear

- (2) 8mm x 25mm Combo Bolts

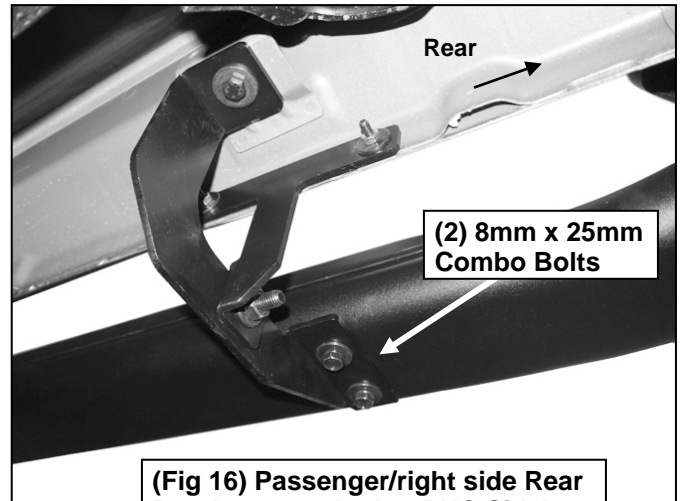

(Fig 16) Passenger/right side Rear Brackets attached to PNC Sidebar



Complete Installation