

PARTS LIST:

1	Driver/Left Sidebar	18	8mm-1.25 x 30 Hex Bolts
1	Passenger/Right Sidebar	24	8mm x 24mm x 2mm Flat Washers
1	Driver Front Mounting Bracket	12	8mm Lock Washers
1	Passenger Front Mounting Bracket	6	8mm Hex Nuts
2	Driver Center/Rear Mounting Brackets	6	8mm Nylon Lock Nuts
2	Passenger Center/Rear Mounting Brackets	12	8mm-1.25 x 25mm Combination Hex Bolts
3	Support Brackets (DS Front & PS Center/Rear)	12	6mm x 25mm Hex Bolts
3	Support Brackets (PS Front & DS Center/Rear)	24	6mm x 22mm x 2mm Flat Washers
6	8mm Nut/Bolt Plates	12	6mm Nylon Lock Nuts
6	8mm Plastic Retainers		

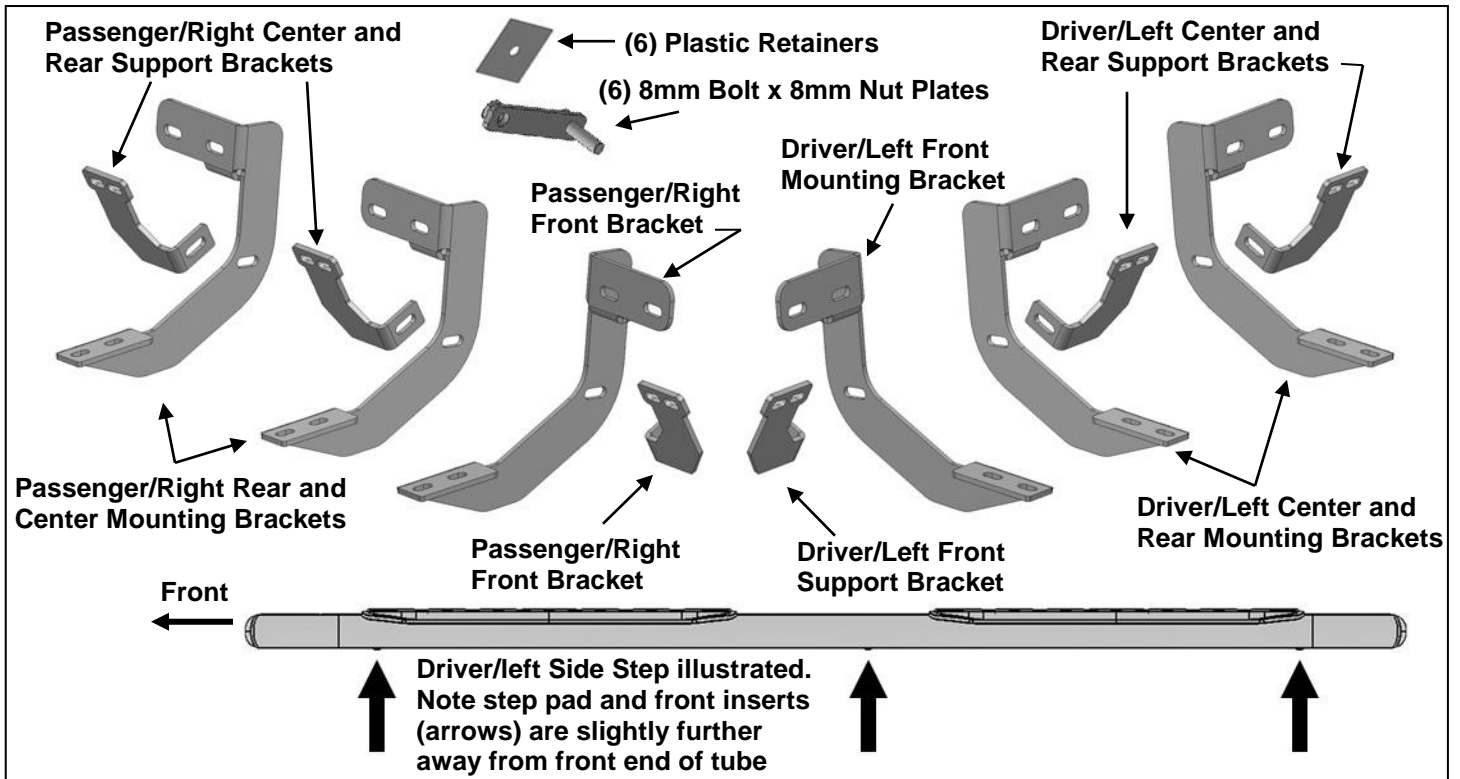

PROCEDURE:

1. REMOVE CONTENTS FROM BOX. VERIFY ALL PARTS ARE PRESENT. READ INSTRUCTIONS CAREFULLY BEFORE STARTING INSTALLATION. DRILLING MAY BE REQUIRED.
2. Starting at the driver side-front of the vehicle, remove the sealing tape covering the factory holes in the side of the inner panel, **(Figure 1)**.
3. Determine the correct procedure to attach the driver side front Bracket for your model/year:

Models without factory threaded inserts in body panel:

 - a. Partially thread an 8mm Hex Bolt onto the threaded end of a 8mm Bolt and Nut Plate, **(Figure 2)**. Thread the Hex Bolt in until it is flush with the welded nut, **(Figure 3)**. Use the Hex Bolt as a handle and insert the Bolt and Nut Plate into the oval hole, **(Figure 4)**. Feed the threaded bolt on the Bolt Plate through one of the hex shaped factory holes. Thread (1) 8mm Plastic Retainer onto the threaded end and down tight against the body panel, **(Figure 5)**. **NOTE:** The Plastic Retainer is designed to keep the Bolt/Nut Plate from falling into the body panel and to aid in Bracket installation.
 - b. Select the driver side front Mounting Bracket, **(Figure 6)**. Attach the Bracket to the threaded end of the Bolt Plate with (1) 8mm Flat Washer, (1) 9mm Lock washer and (1) 8mm Hex Nut, **(Figure 7)**. Do not tighten at this time.
 - c. Remove the 8mm Hex Bolt from the nut on the Bolt Plate from **Step 3a**. Rotate the Bolt on the Bolt Plate until the threaded nut lines up with the remaining hole in the Mounting Bracket and

body panel, **(Figures 7 & 8)**. Attach the Bracket to the threaded Nut Plate with (1) 8mm x 30mm Hex Bolt, (1) 8mm Lock Washer and (1) 8mm Flat Washer, **(Figure 8)**. Do not fully tighten hardware at this time.

Models with factory threaded inserts:

- a. Attach the driver side Front Bracket to the threaded inserts with (2) 8mm x 30mm Hex Bolts, (2) 8mm Lock Washers and (2) 8mm Flat Washer, **(Figures 9 & 10)**. Leave hardware loose.
4. Next, select the driver side front Support Bracket. Attach the Bracket to the front facing side of the front Bracket with (1) 8mm x 30mm Hex Bolt, (2) 8mm Flat Washers and (1) 8mm Nylon Lock Nut, **(Figure 11)**. Rotate the Support Bracket to the back of the pinch weld. Line up the slots in the top of the Support Bracket with the (2) factory holes in the pinch weld. Attach the Bracket to the back of the pinch weld with (2) 6mm x 25mm Hex Bolts, (4) 6mm Flat Washers and (2) 6mm Nylon Lock Nuts, **(Figures 12 & 13)**. Do not fully tighten hardware at this time. **IMPORTANT:** 2009-12 models are not equipped with factory holes and will require drilling through the pinch weld to attach the Support Bracket. Do not drill through pinch weld at this time, **(see Step 8)**.
5. Move along the side of the body panel to the center mounting location, **(Figure 14)**. Repeat the appropriate **Step 3** to install the driver side center Bracket, **(Figure 15)**. **IMPORTANT:** The front bracket is different from the center and rear Mounting Brackets, (see illustration above-note direction of mounting plate). Select (1) driver side center/rear Support Bracket. Repeat **Step 4** to attach the Support Bracket to the back of the center bracket and factory holes (if equipped) in the pinch weld, **(Figure 16)**.
6. Move to the rear location, **(Figure 17)**. Repeat **Step 5** to install the rear Mounting Bracket, **(Figure 18)**.
7. Select the driver/left Sidebar. Carefully position the Driver Sidebar onto the (3) Mounting Brackets. **IMPORTANT:** Do not slide, (front to back or rotate), the Sidebar on the Brackets or damage to the finish on the Sidebar may result. Attach the Side Step to the (3) Brackets with (6) 8mm Combination Hex Bolts, **(Figures 19 & 20)**. Do not fully tighten at this time.
8. Properly level and adjust the Sidebar and fully tighten all hardware.
2009-12 models requiring drilling for driver side Support Brackets:
 - a. Make sure the Sidebar is level to the vehicle. Adjust and tighten all mounting hardware.
 - b. Line up the slots on the Support Brackets with the back of the pinch weld. Mark the location of the slots onto the pinch weld.
 - c. Drill (2) 1/4" holes through the pinch weld for each Support Bracket. **IMPORTANT:** Do not drill too close to the bottom edge of the pinch weld. Adjust the Brackets as necessary to move the slots up the body panel away from the edge. Drill the holes toward the outside of the marked slots.
 - d. Attach each Support Bracket to the pinch weld with (2) 6mm Hex Bolts, (4) 6mm Flat Washers and (2) 6mm Nylon Lock Nuts, **(Figures 12, 13, 16, 18 & 19)**. Check for level then fully tighten all hardware.
9. Move to the passenger side of the vehicle. Remove tape covering front, center and rear locations. Repeat **Steps 2—8** for passenger side Mounting Bracket installation. **NOTE:** Refer to the illustration on **Page 1** to identify the correct Mounting Bracket for each of the remaining locations.
10. Do periodic inspections to the installation to make sure that all hardware is secure and tight.

To protect your investment, wax this product after installing. Regular waxing is recommended to add a protective layer over the finish. Do not use any type of polish or wax that may contain abrasives that could damage the finish.

For stainless steel: Aluminum polish may be used to polish small scratches and scuffs on the finish. Mild soap may be used also to clean the Side Steps.

For gloss black finishes: Mild soap may be used to clean the Side Steps.

Driver Side Installation Pictured

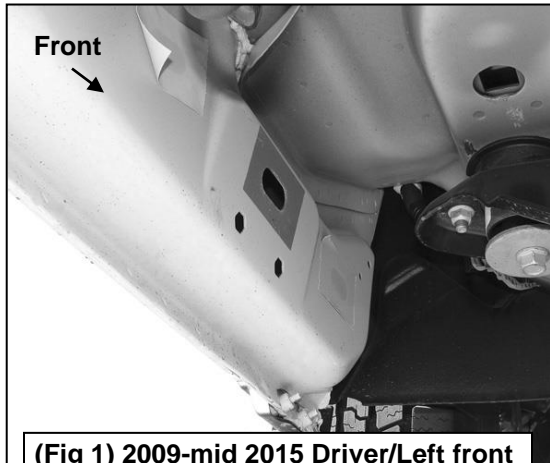

(Fig 1) 2009-mid 2015 Driver/Left front mounting location (No factory holes in pinch weld 2009-2012 models)

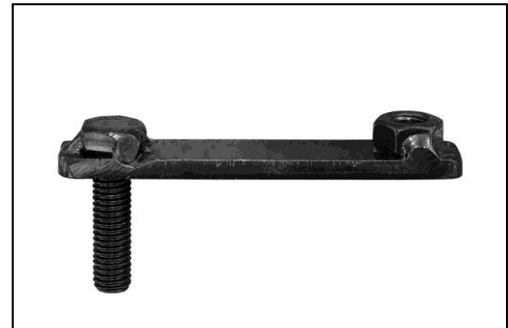

(Fig 2) 8mm Bolt-8mm Nut Plate, NOTE: 8mm Bolt-Nut Plate is not required on models with threaded inserts

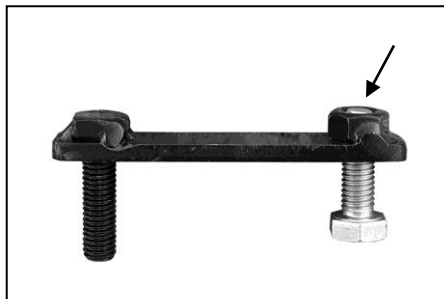

(Fig 3) Thread (1) 8mm Hex Bolt into the nut on the plate. Stop when bolt reaches end of nut as pictured

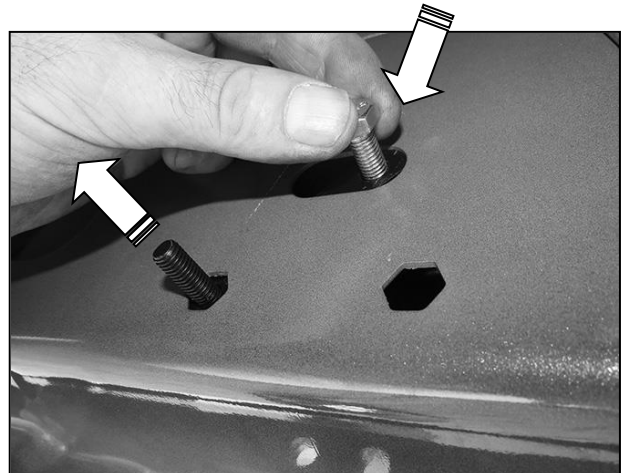

(Fig 4) Use the loose Hex Bolt as a handle. Insert the Bolt Plate into the oval hole and feed the threaded end out either factory hex shaped hole. IMPORTANT: Do not let go of the hex bolt until after Plastic Retainer has been threaded onto bolt (Fig 5)

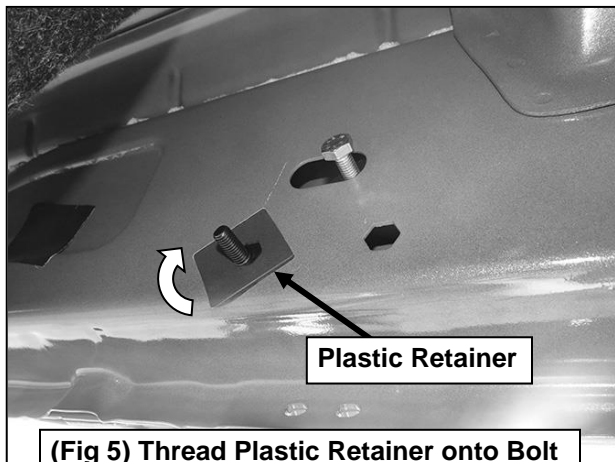

(Fig 5) Thread Plastic Retainer onto Bolt Plate to hold Bolt Plate in position.

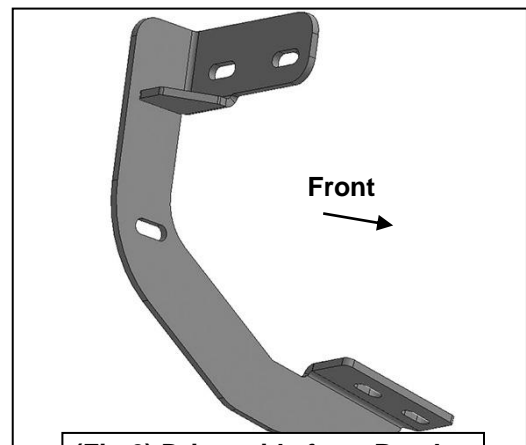

(Fig 6) Driver side front Bracket

Driver Side Installation Pictured

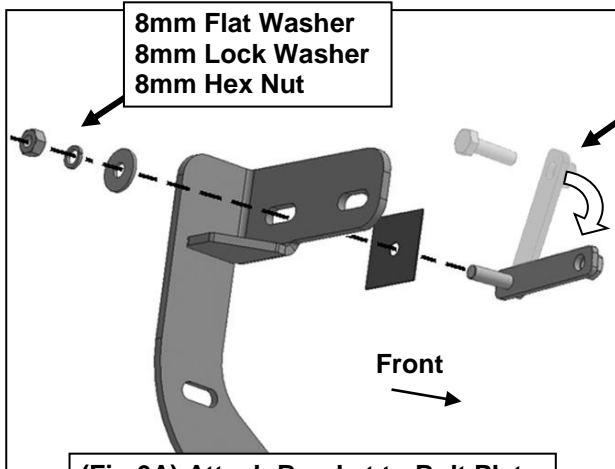

(Fig 6A) Attach Bracket to Bolt Plate

Remove Hex Bolt, rotate Bolt/Nut Plate to line up threaded nut with body panel and Mounting Bracket (see arrow)

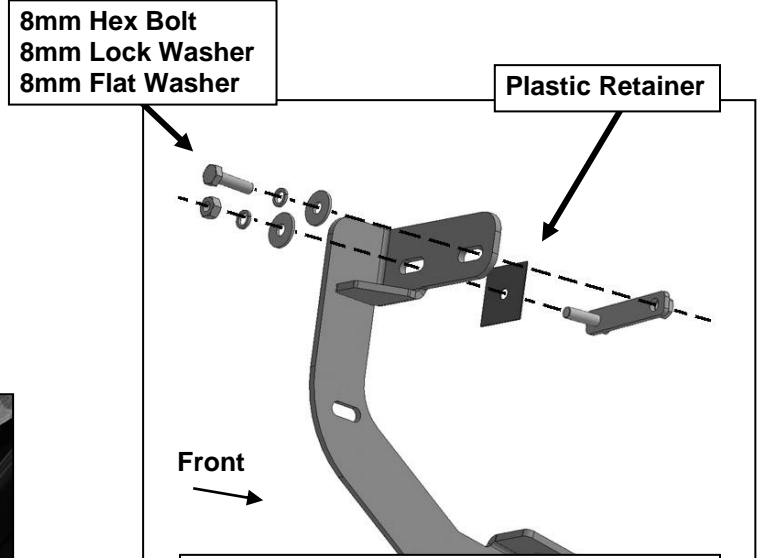

(Fig 6B) Attach Bracket to threaded end of Bolt Plate first. Remove 8mm Hex Bolt (see Fig 3). Rotate Bolt Plate to line up with remaining factory hex shaped hole.

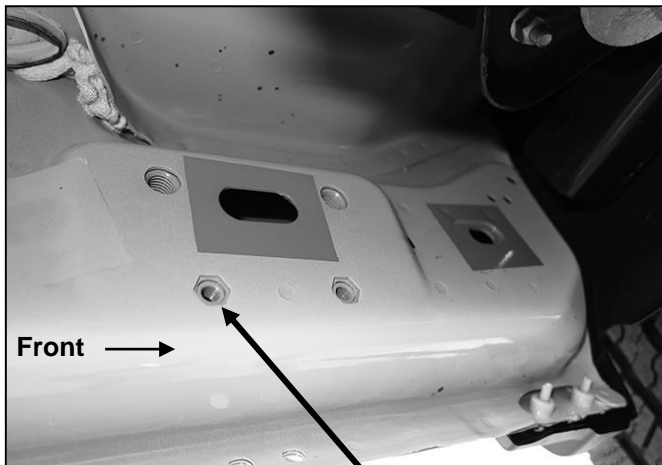

(Fig 7) Driver side front mid 2015-on, an example of models with factory installed threaded inserts

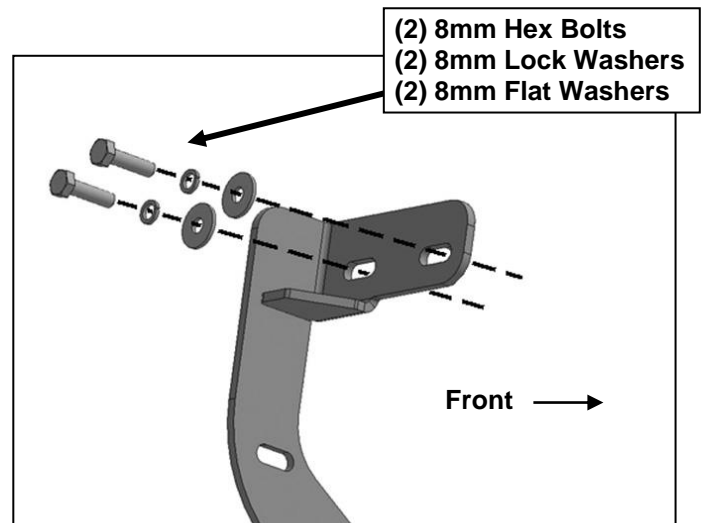

(Fig 8) Driver side front models with factory installed threaded inserts. Bolt Plate not required

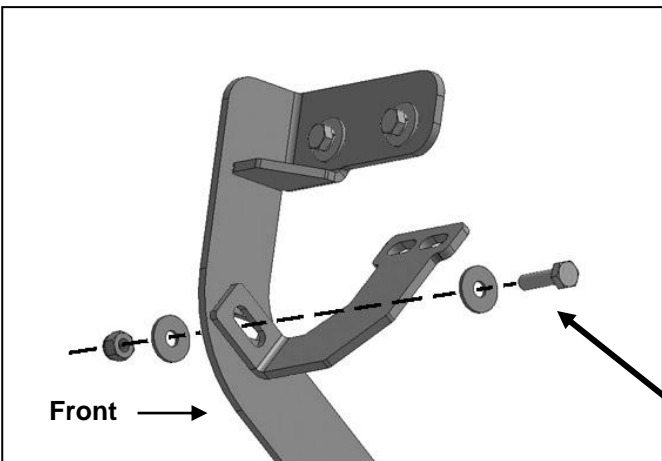

(Fig 9) Attach Driver/Left front Support Bracket to front facing side of Mounting Bracket

8mm Hex Bolt
(2) 8mm Flat Washers
8mm Nylon Lock Nut

Driver Side Installation Pictured

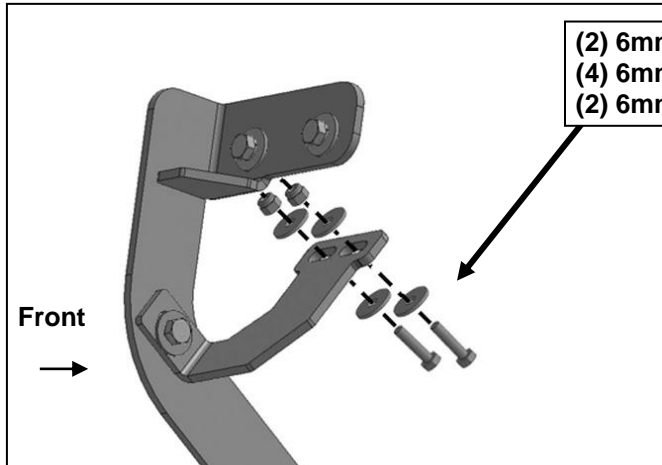

(Fig 10) Attach Support Bracket to back of pinch weld (models with factory holes in pinch weld only)

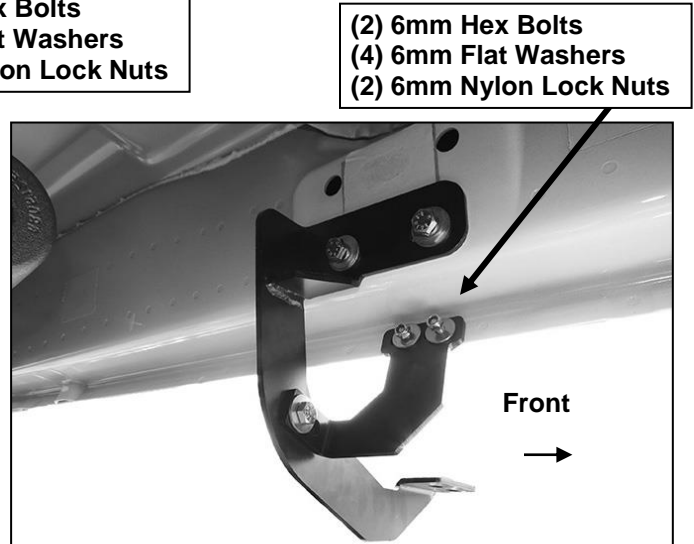

(Fig 11) Driver side front Bracket assembly

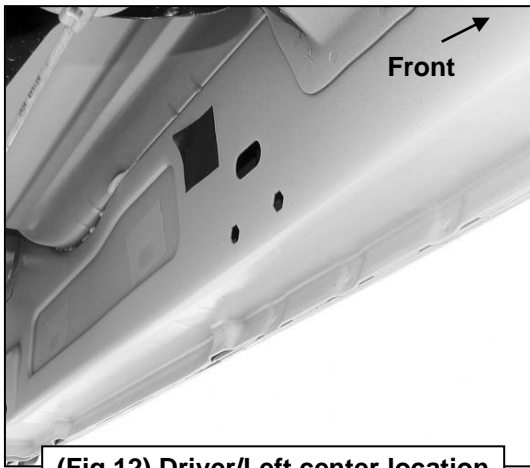

(Fig 12) Driver/Left center location

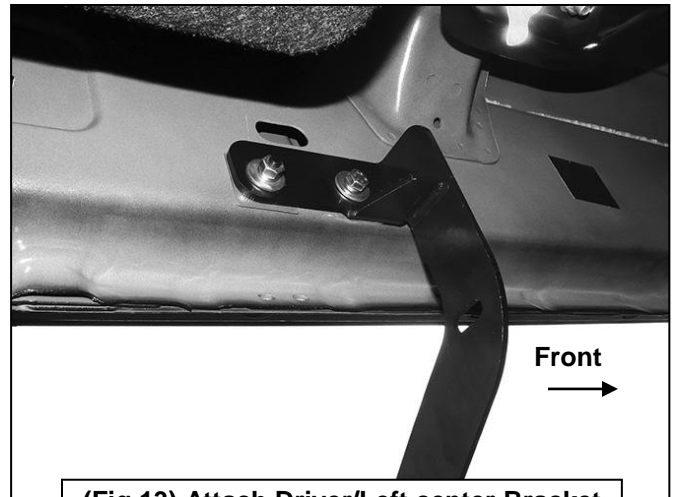

(Fig 13) Attach Driver/Left center Bracket

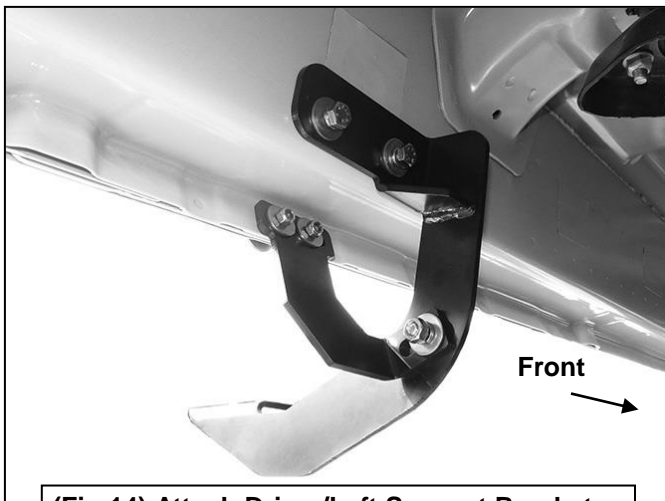

(Fig 14) Attach Driver/Left Support Bracket to back of Center Mounting Bracket

IMPORTANT: 2009-2012 models without holes in pinch weld will require drilling 1/4" holes through pinch weld to attach driver side front support bracket. Do complete installation of sidebars first, level sidebar before drilling holes for support bracket.

Driver Side Installation Pictured

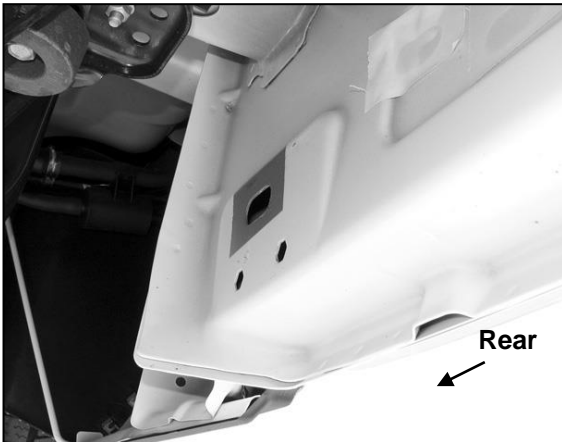

(Fig 15) Driver/Left rear mounting location



(Fig 16) Driver/Left rear Mounting Bracket assembly

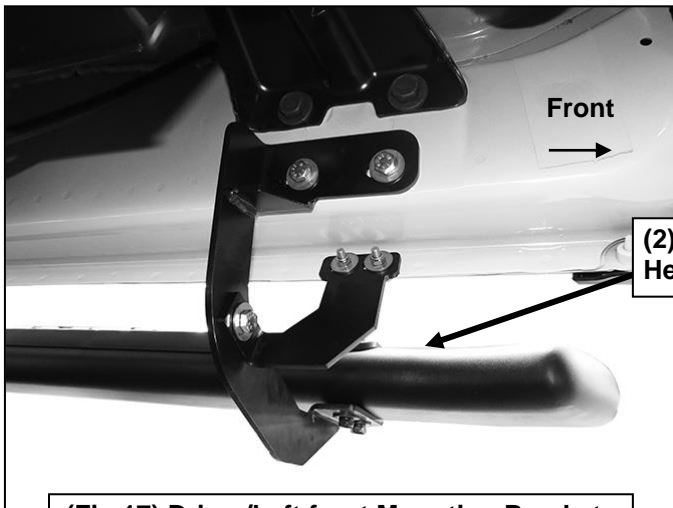

(2) 8mm Combo
Hex Bolts

(Fig 17) Driver/Left front Mounting Brackets

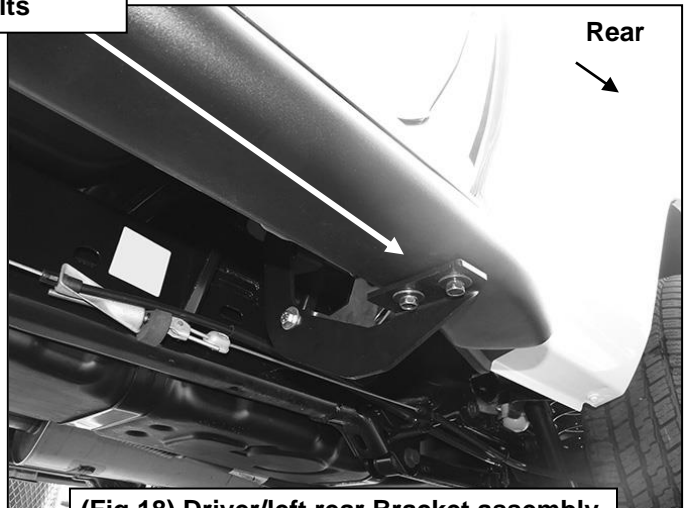

(Fig 18) Driver/left rear Bracket assembly



Installation Complete