

**6IN STRAIGHT/BENT END SIDEBARS
09-14 FORD F-150 SUPER CAB**

PARTS LIST:

Qty	Description	Qty	Description
1	Driver/Left Side Bar	8	8-1.25mm x 30mm Hex Bolts
1	Passenger/Right Side Bar	16	8-1.25mm x 25mm Hex Bolts
2	Driver/Left Front-Passenger/Right Rear Mounting Brackets	8	8mm x 28mm OD x 3mm Flat Washers
2	Passenger/Right Front- Driver/Left Rear Mounting Brackets	24	8mm x 24mm OD x 2mm Flat Washers
8	8mm Deep Clip Nuts	24	8mm Lock Washers
		8	8mm Hex Nuts

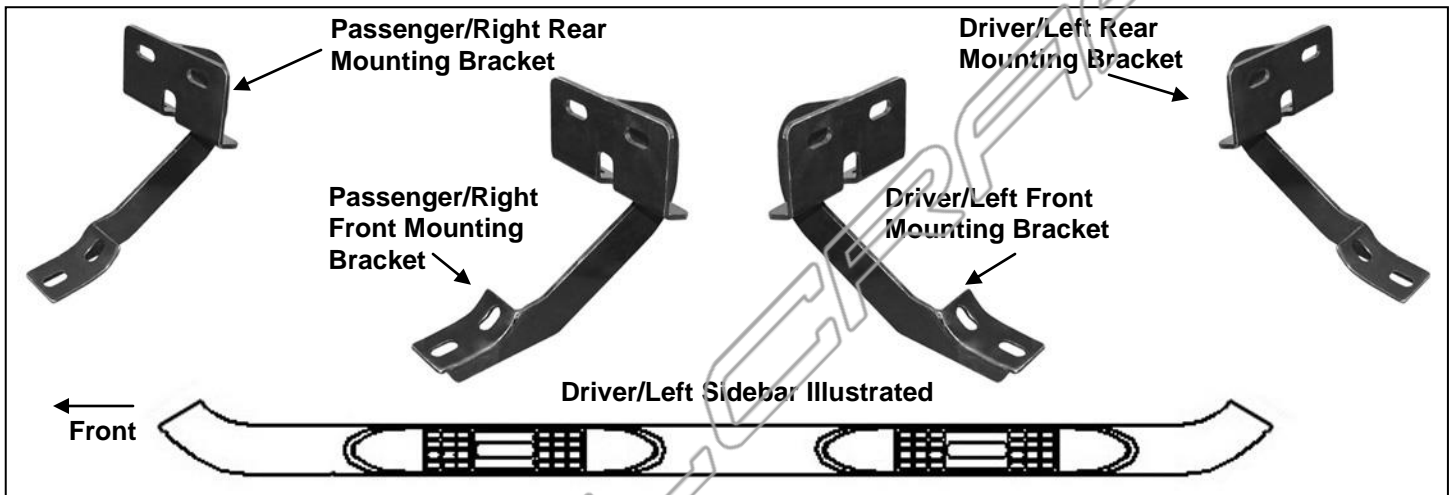

PROCEDURE:

- REMOVE CONTENTS FROM BOX. VERIFY ALL PARTS ARE PRESENT. READ INSTRUCTIONS CAREFULLY BEFORE STARTING INSTALLATION.**
- Starting on the driver side of the vehicle, locate the (2) holes in the bottom of the body panel, (pinch weld). Next locate the rectangular opening and (2) small holes in the inner body panel directly above the holes in the pinch weld. **(Figure 1).** **NOTE:** The holes in the inner panel may be covered with sealing tape or insulation.
- Slide (1) 8mm Clip Nut into the rectangular opening with the nut towards the inside. Line up the threaded nut on the clip with the round hole, **(Figure 1).** Repeat to install 2nd 8mm Clip Nut in remaining hole location.
- Partially attach the driver side Mounting Bracket to the (2) Clip Nuts with the included (2) 8mm x 30mm Hex Bolts, (2) 8mm Lock Washers and (2) 8mm x 28mm Large Flat Washers, **(Figure 2).** Depending on model and year, the brake cable may be run on the inside or outside of the Bracket. Do not tighten hardware at this time. **NOTE:** The cradle on the front Bracket should face to the rear.
- Align the bottom holes in the front Bracket with the (2) holes in the pinch weld. Bolt the Bracket to the pinch weld using the included (2) 8mm x 25mm Hex Bolts, (4) 8mm STD Flat Washers, (2) 8mm Lock Washers and (2) 8mm Hex Nuts, **(Figure 2).** **NOTE:** Insert the bolts up from the bottom of the pinch weld and through the Bracket.
- Continue along the cab to the rear mounting location. Locate the last (2) mounting holes in the pinch weld towards the back of the cab, **(Figure 3).** Repeat **Steps 2—5** for rear mounting Bracket installation. **NOTE:** The cradle on the rear Bracket should face the front of the vehicle, **(Figures 3 & 4).**
- Carefully position the Sidebar onto the Mounting Brackets. Attach Sidebar to the Brackets with the included (4) 8mm x 25mm Hex Bolts, (4) 8mm Lock Washers and (4) 8mm STD Flat Washers, **(Figure 4).** Do not tighten hardware at this time.
- Level and adjust the Sidebar properly and tighten all hardware.
- Repeat **Steps 2—8** for passenger Sidebar installation.
- Do periodic inspections to the installation to make sure that all hardware is secure and tight.

**6IN STRAIGHT/BENT END SIDEBARS
09-14 FORD F-150 SUPER CAB**

To protect your investment, wax this product after installing. Regular waxing is recommended to add a protective layer over the finish. Do not use any type of polish or wax that may contain abrasives that could damage the finish.

For stainless steel: Aluminum polish may be used to polish small scratches and scuffs on the finish. Mild soap may be used also to clean the Sidebar.

For gloss black finishes: Mild soap may be used to clean the Sidebar.

Driver Side Installation Pictured

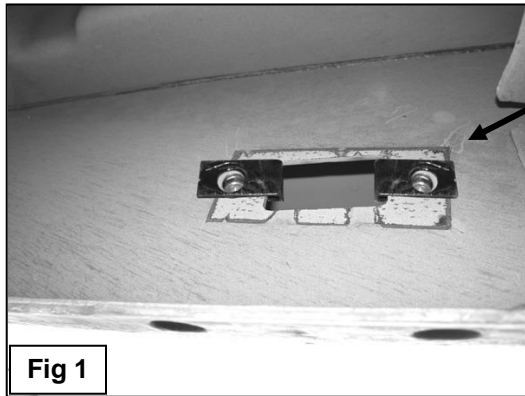

8mm Clip Nuts (hole in body panel shown for example only-location and shape may differ slightly)

8mm x 30mm Hex Bolts
8mm Lock Washers
8mm x 28mm Large Flat Washers

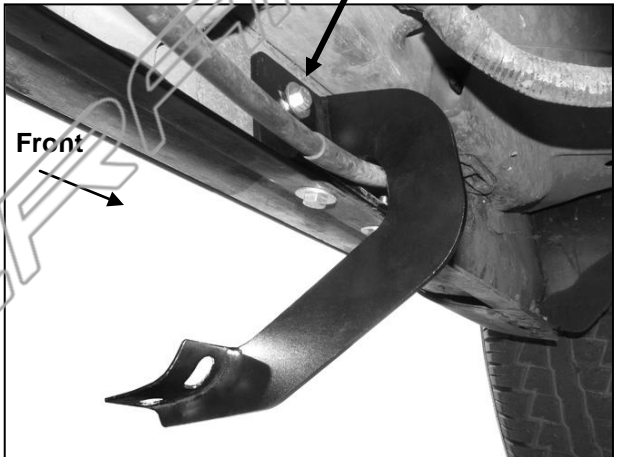

(Fig 2) Driver/left front Mounting Bracket pictured

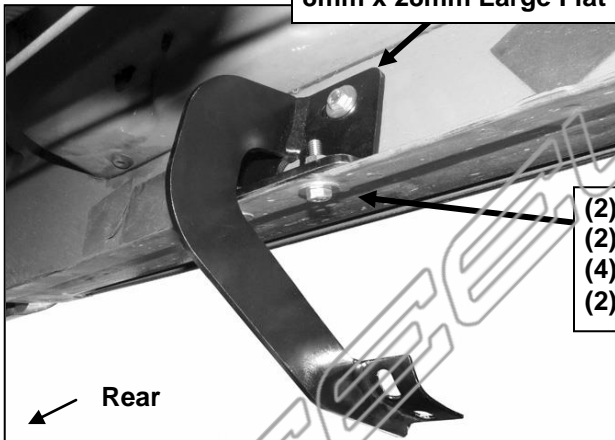

8mm x 30mm Hex Bolts
8mm Lock Washers
8mm x 28mm Large Flat Washers

(2) 8mm x 25mm Hex Bolts
(2) 8mm Lock Washer
(4) 8mm x 24mm STD Flat Washers
(2) 8mm Hex Nuts

(Fig 3) Driver/left rear Mounting Bracket pictured

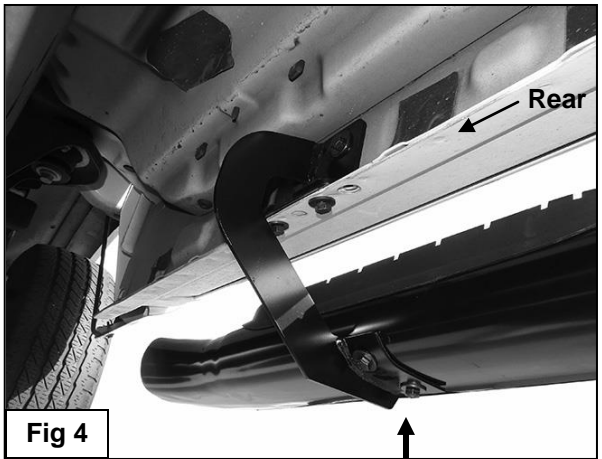

Fig 4

(2) 8mm x 25mm Hex Bolts
(2) 8mm Lock Washer
(2) 8mm x 24mm STD Flat Washers



Complete Installation