

**5" OVAL BENT WHEEL TO WHEEL SIDEBAR
17-18 FORD F250/350/450 SUPERDUTY CREW CAB 6.5 FT STD BED
15-18 FORD F150 CREW CAB 6.5 FT STD BED**

PARTS LIST:

1	Driver/Left Sidebar	18	8mm Plastic Retainers
1	Passenger/Right Sidebar	18	8mm x 24mm x 2mm Flat Washers
6	Mounting Brackets	18	8mm Nylon Lock Nuts
1	Driver/Left Rear Bracket	4	10mm Lock
1	Passenger/Right Rear Bracket	4	10mm x 30mm x 2.5mm Flat Washers
2	10mm x 40mm Bolt Plates	4	10mm Hex Nuts
2	10mm x 35mm Bolt Plates	16	8mm Combo Bolts
8	10mm Plastic Retainers		

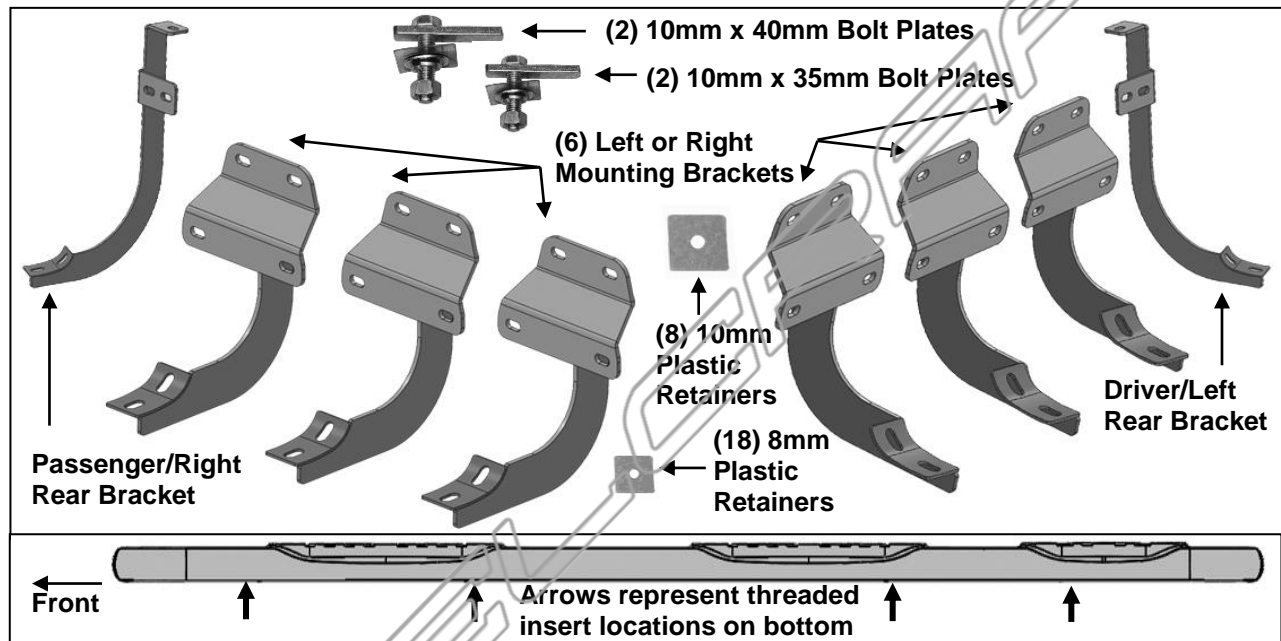

PROCEDURE:

- 1. REMOVE CONTENTS FROM BOX. VERIFY ALL PARTS ARE PRESENT. READ INSTRUCTIONS CAREFULLY BEFORE STARTING INSTALLATION. ASSISTANCE IS RECOMMENDED.**
- Start the installation under the driver/left side of the vehicle. Locate the front factory sidebar mounting location, (threaded studs), along the inner side of the body, **(Figure 1)**.
- Slide (1) Plastic Washer, **(Figure 2)**, over each of the (3) factory mounting studs in the body panel, **(Figure 3)**. **IMPORTANT:** The Plastic Retainers are designed to prevent corrosion between the aluminum body panel and steel mounting brackets. **Do not install Brackets without Plastic Retainer.**
- Attach (1) Mounting Bracket to the (3) threaded studs with the included (3) 8mm Flat Washers and (3) 8mm Nylon Lock Nuts **(Figure 4)**. All (6) Mounting Brackets are universal and will fit left or right side. Leave brackets loose at this time.
- Repeat **Steps 3—4** for the 2nd and 3rd Mounting Bracket, **(Figures 5—6)**.
- Move to the driver side rear of the vehicle and locate the oval hole in the body mount support, **(Figures 7—8)**. Select (1) 10mm x 40mm Bolt Plate, and (1) 10mm Plastic Retainer, **(Figure 9)**. Thread the Retainer all the way down the threaded end of the Bolt Plate. By hand, (pliers can also be used), bend the sides of the Plastic Washer up around the sides of the Bolt Plate, **(Figure 10)**.
- Insert the 10mm x 40mm Bolt Plate and Retainer into the oval hole. Once the Bolt Plate is in the hole, thread a second Plastic Retainer down until it is tight against the floor panel, **(Figure 11)**. If necessary, use scissors to trim plastic washer for easier installation. **IMPORTANT: Do not install the rear Bolt Plates and Brackets without the Plastic Retainer.**
- Locate the square hole in the body mount support, **(Figures 7—8)**. Select (1) 10mm x 35mm Bolt Plate, and (1) 10mm Plastic Retainer, **(Figure 9)**. Thread the Retainer all the way down the threaded end of the Bolt Plate. By hand, (pliers can also be used), bend the sides of the Plastic Retainer up around the sides of the Bolt Plate, **(Figure 10)**. Insert the 10mm x 35mm Bolt Plate and Retainer into the square

5" OVAL BENT WHEEL TO WHEEL SIDEBAR
17-18 FORD F250/350/450 SUPERDUTY CREW CAB 6.5 FT STD BED
15-18 FORD F150 CREW CAB 6.5 FT STD BED

hole. Once the Bolt Plate is in the hole, thread a second Plastic Washer down until it is tight against the floor panel, **(Figure 11)**.

9. Attach the Driver/Left side Rear Bracket to the Bolt Plates with (2) 10mm Flat Washers, (2) 10mm Lock Washers and (2) 10mm Hex Nuts, **(Figure 12)**. Snug but do not tighten hardware at this time.
10. Select the driver/left Side Step. Carefully position the Side Step onto the (4) Brackets. **IMPORTANT:** Do not slide, (front to back or rotate), the Side Step on the Brackets or damage to the finish may result. Attach the Side Step to the Mounting Brackets with (4) 8mm Combo Hex Bolts, **(Figure 13)**. Do not tighten at this time.
11. Level and adjust Side Step properly and tighten all hardware.
12. Repeat **Steps 1—11** for passenger/right Side Step installation.
13. Do periodic inspections to the installation to make sure that all hardware is secure and tight.

To protect your investment, wax this product after installing. Regular waxing is recommended to add a protective layer over the finish. Do not use any type of polish or wax that may contain abrasives that could damage the finish.

For stainless steel: Aluminum polish may be used to polish small scratches and scuffs on the finish. Mild soap may be used also to clean the Side Step.

For gloss black finishes: Mild soap may be used to clean the Side Step.

Driver/Left Side Installation Pictured

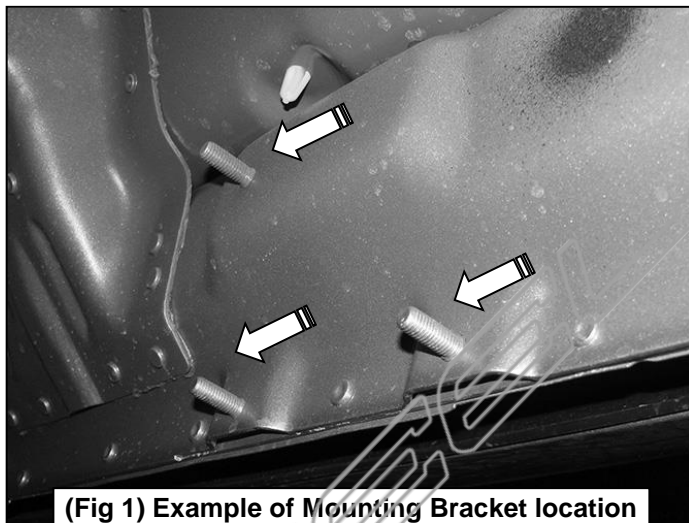

(Fig 1) Example of Mounting Bracket location

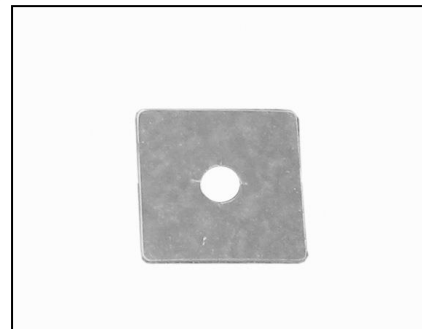

(Fig 2) Plastic Insulation Washer

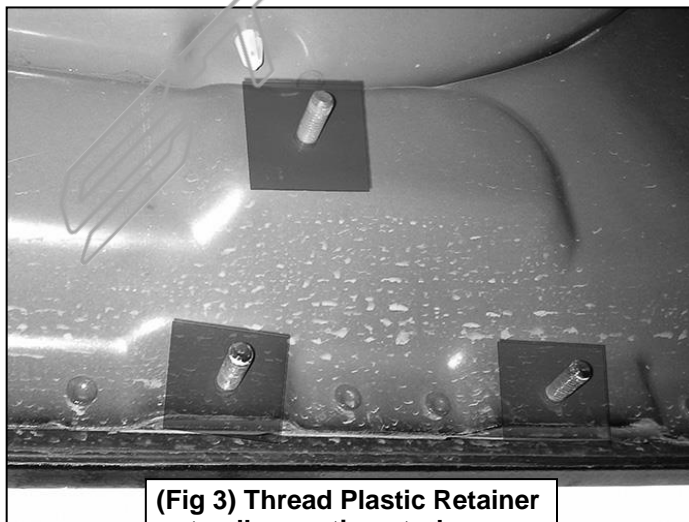

(Fig 3) Thread Plastic Retainer onto all mounting studs

Note: All Mounting Bracket cradles should face towards front of vehicle

**(3) 8mm Plastic Retainer
(3) 8mm Flat Washers
(3) 8mm Nylon Lock Nuts**

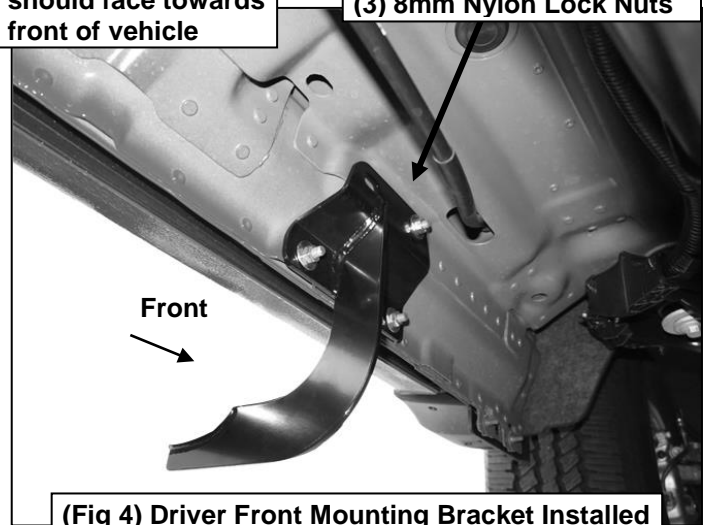

(Fig 4) Driver Front Mounting Bracket Installed

**5" OVAL BENT WHEEL TO WHEEL SIDEBAR
17-18 FORD F250/350/450 SUPERDUTY CREW CAB 6.5 FT STD BED
15-18 FORD F150 CREW CAB 6.5 FT STD BED**

Driver/Left Side Installation Pictured

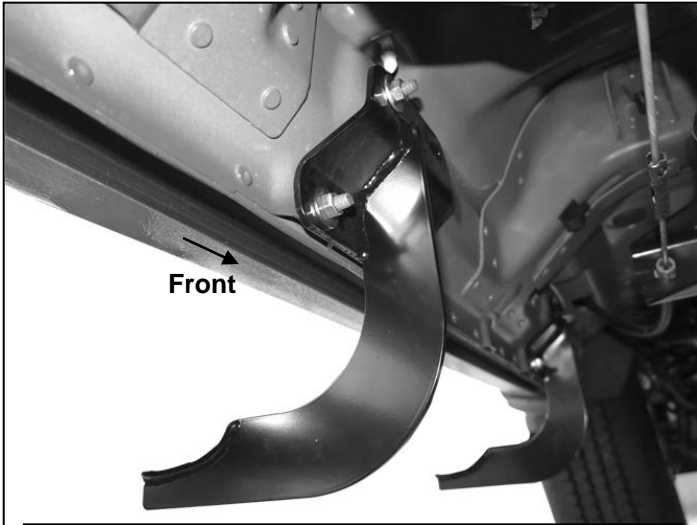

(Fig 5) Driver side 2nd Mounting Bracket Installed

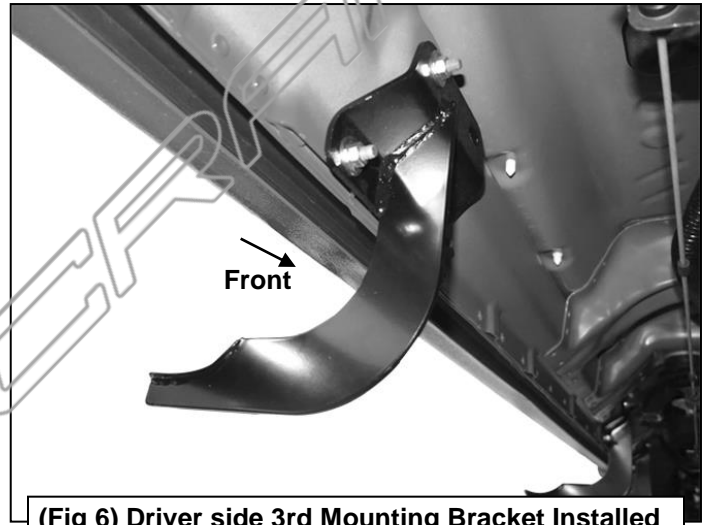

(Fig 6) Driver side 3rd Mounting Bracket Installed

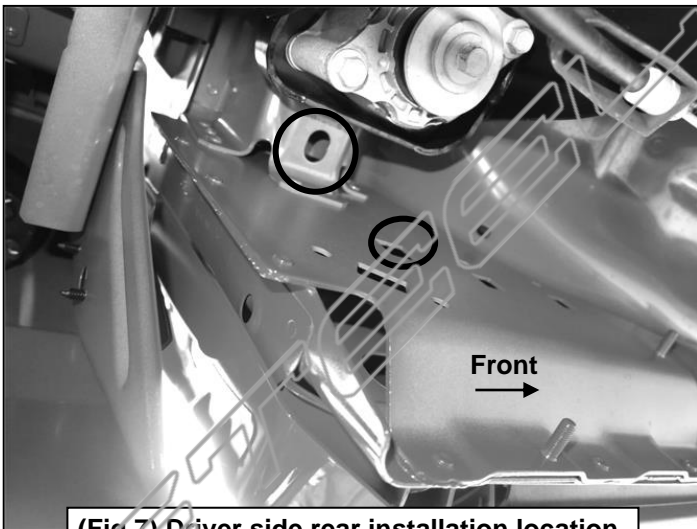

(Fig 7) Driver side rear installation location

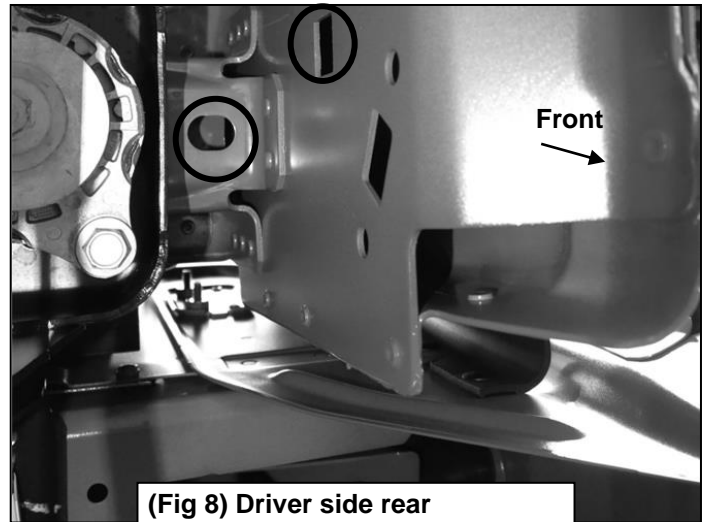

(Fig 8) Driver side rear installation location bottom view

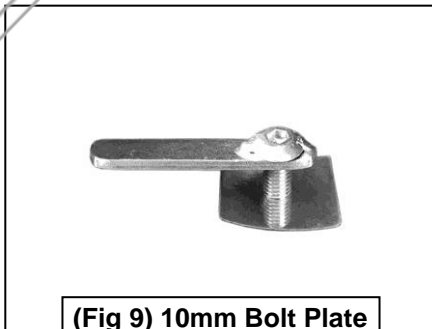

(Fig 9) 10mm Bolt Plate with Plastic Retainer

5" OVAL BENT WHEEL TO WHEEL SIDEBAR
17-18 FORD F250/350/450 SUPERDUTY CREW CAB 6.5 FT STD BED
15-18 FORD F150 CREW CAB 6.5 FT STD BED

Driver/Left Side Installation Pictured

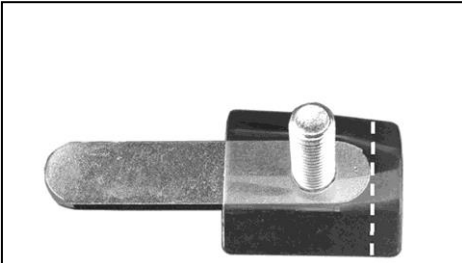

(Fig 10) Bend sides of Plastic Retainer up around Bolt Plate. If necessary, use scissors to cut off overhanging plastic. Cut Retainer on Bolt Plate installations only

- (2) 10mm Flat Washers
- (2) 10mm Lock Washers
- (2) 10mm Hex Nuts

Note: Driver Rear Bracket cradle should face towards the rear

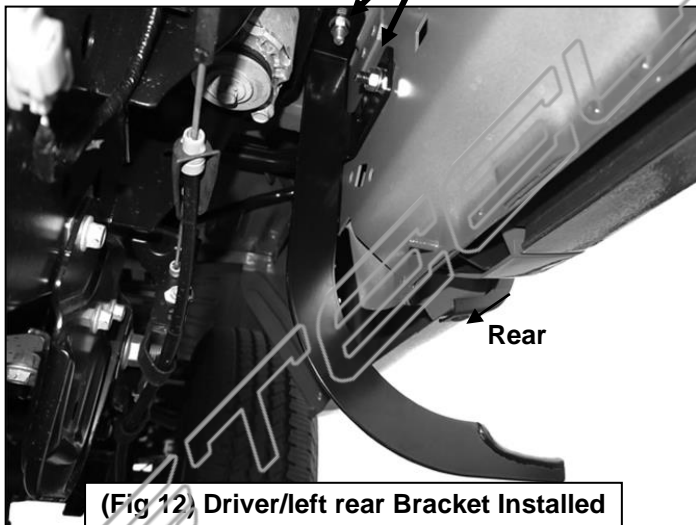

(Fig 12) Driver/left rear Bracket Installed

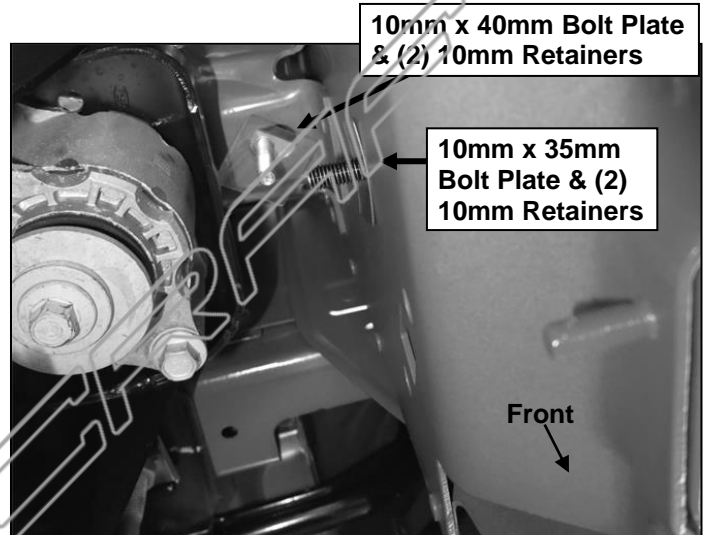

10mm x 40mm Bolt Plate & (2) 10mm Retainers

10mm x 35mm Bolt Plate & (2) 10mm Retainers

Front

(Fig 11) Driver side Bolt Plate and Retainers Installed

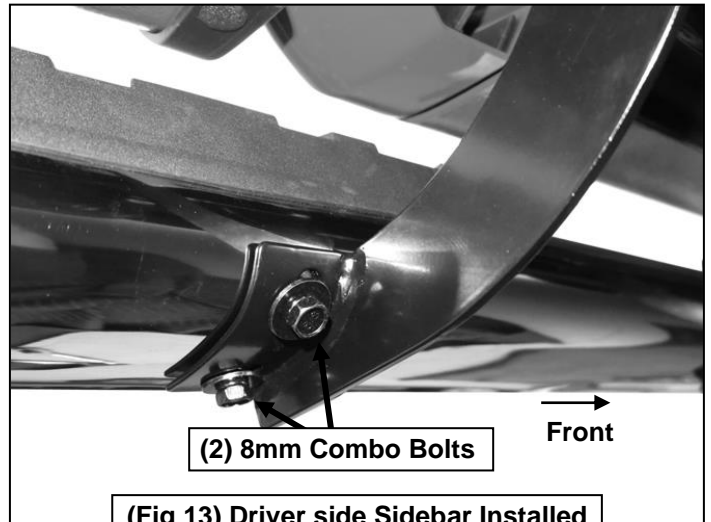

(2) 8mm Combo Bolts

Front

(Fig 13) Driver side Sidebar Installed



Complete Installation