

PARTS LIST:

1	Driver/left T6 Sidebar (76in)	6	8-1.25mm x 35mm Double Bolt Plates
1	Passenger/right T6 Sidebar (76in)	12	8-1.25mm x 25mm Hex Bolts
4	Front and Center Brackets (use left or right)	24	8mm x 24mm x 2mm Flat Washers
1	Driver/left side Rear Bracket	24	8mm Lock Washers
1	Passenger/right side Rear Bracket	12	8-1.25mm Hex Nuts
12	8-1.25mm Clip-On Nuts		

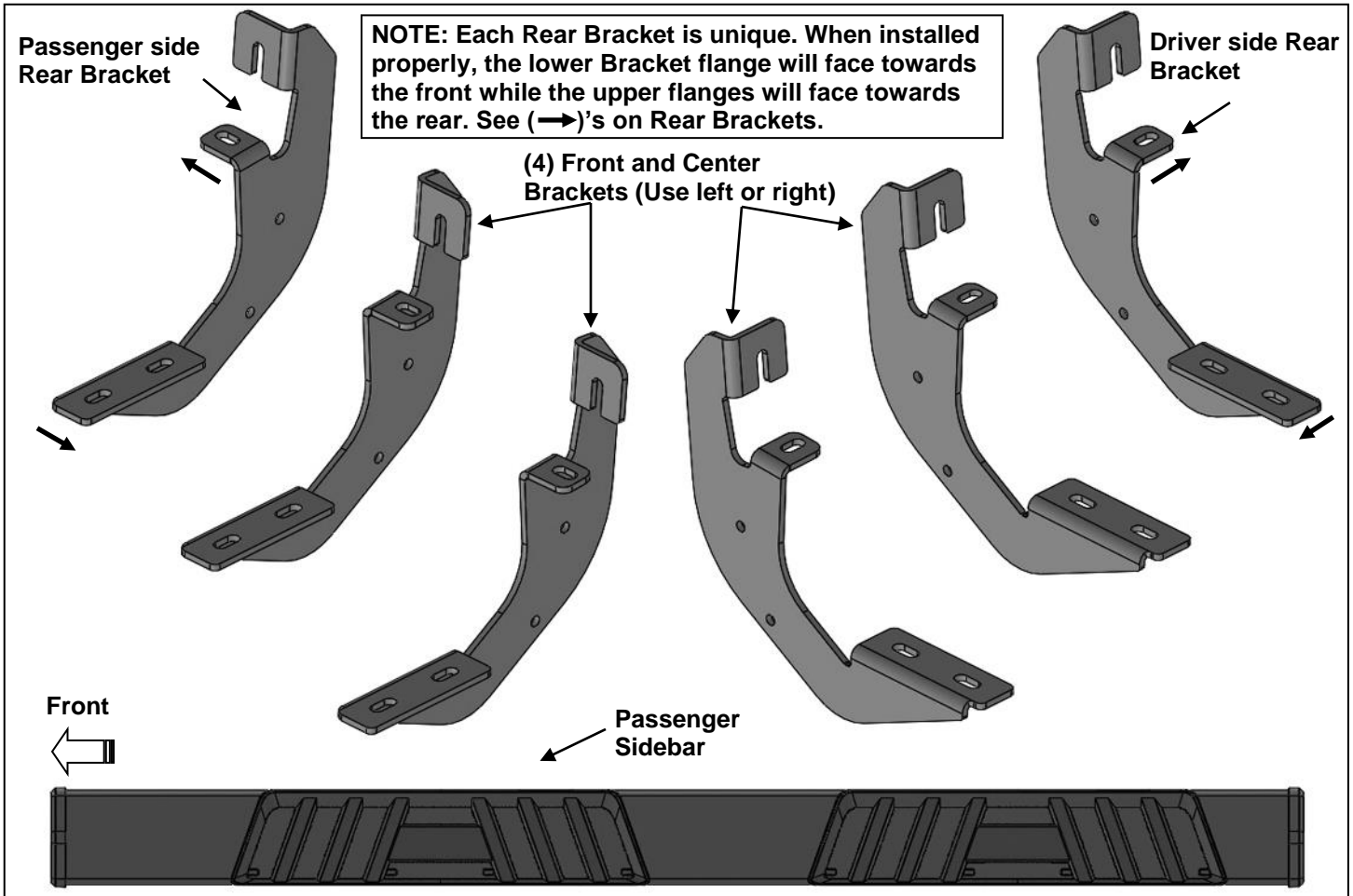

PROCEDURE:

REMOVE CONTENTS FROM BOX. VERIFY ALL PARTS ARE PRESENT. READ INSTRUCTIONS CAREFULLY BEFORE STARTING INSTALLATION. ASSISTANCE IS RECOMMENDED.

1. Start the installation under the passenger side of the vehicle. Locate the (4) factory mounting locations along the bottom and inner side of the body, **(Figure 1)**. Mounting Brackets will bolt to the 1st, 2nd and 4th mounting locations. **NOTE:** It may help to hold a Bracket up in place to help determine the mounting holes to use along the bottom and inner side of the body.
2. Remove rubber plugs as necessary from the (2) factory mounting holes, **(Figure 2)**. Select (1) 8mm Clip Nut. Slide the Clip Nut into the large hole and over the smaller hole next to it. Line up threaded nut on the Clip Nut with smaller hole in body panel, **(Figure 3)**. Repeat to install a 2nd Clip Nut in the remaining front mounting hole.
3. Select (1) Front/Center Bracket. **IMPORTANT:** Use the illustration above to help determine the correct Bracket. Attach the Bracket to the (2) Clip Nuts with (2) 8mm Hex Bolts, (2) 8mm Lock Washers and (2) 8mm Flat Washers, **(Figures 4 & 5)**. Snug but do not fully tighten the hardware.

4. Move along to the 2nd mounting location, (**Figures 1, 2 & 6**). Repeat **Steps 2 & 3** to install (1) Front/Center Bracket on the center location, (**Figure 7**).
5. Continue to the last mounting location, (**Figures 1, 2 & 8**). Repeat **Step 2** to install (2) 8mm Clip Nuts, (**Figure 8**). Next, select the Passenger side Rear Bracket, (**Figure 9**). **IMPORTANT:** Use the illustration above to help determine the correct Bracket. Attach the Bracket to the (2) Clip Nuts using (2) 8mm Hex Bolts, (2) 8mm Lock Washers and (2) 8mm Flat Washers.
6. Select the passenger Sidebar. Use the illustration above to help determine the correct Sidebar. **NOTE:** The front stepping pad on the Sidebar is farther away from the front end. Place the Sidebar on top of the Brackets. Locate the channels in the bottom of the Sidebar. Select (3) 8mm Double Bolt Plates, (**Figure 10**). Insert the Bolt Plates into the channels in the bottom of the Sidebar closest to the Brackets, (**Figure 11**). Lift the Sidebar up and guide the studs through the Brackets.
7. Attach the Sidebar to the Brackets with (6) 8mm Flat Washer, (6) 8mm Lock Washers and (6) 8mm Hex Nuts, (**Figures 12—15**).
8. Properly level and adjust the Sidebar and fully tighten all hardware.
9. Repeat **Steps 1—8** for driver Sidebar installation.
10. Do periodic inspections to the installation to make sure that all hardware is secure and tight.

To protect your investment, wax this product after installing. Regular waxing is recommended to add a protective layer over the finish. Do not use any type of polish or wax that may contain abrasives that could damage the finish. Mild soap may be used also to clean the Sidebars.

Passenger/right Side Installation Pictured

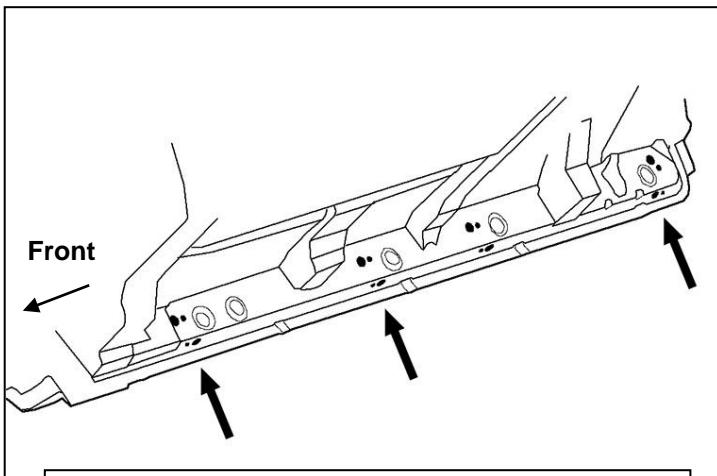

(Fig 1) Passenger side mounting locations along bottom and back of body panel illustrated

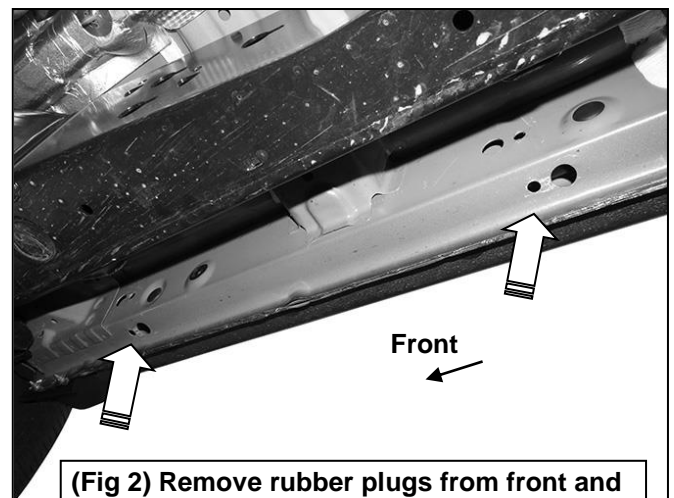

(Fig 2) Remove rubber plugs from front and center mounting locations (arrows)

Passenger/right Side Installation Pictured

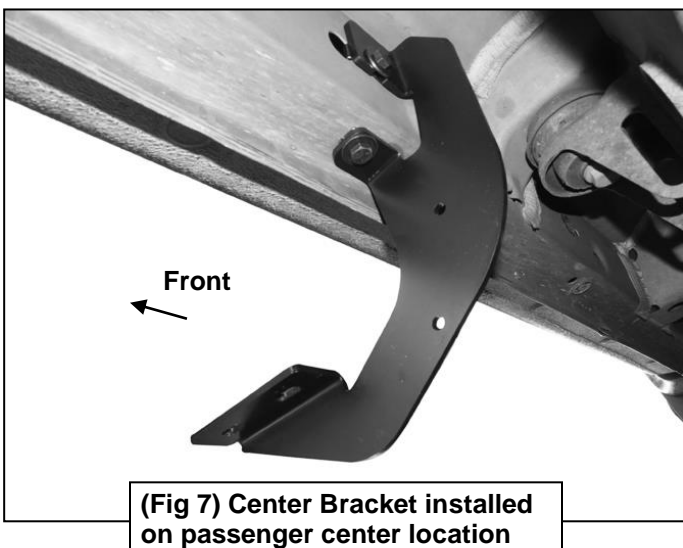
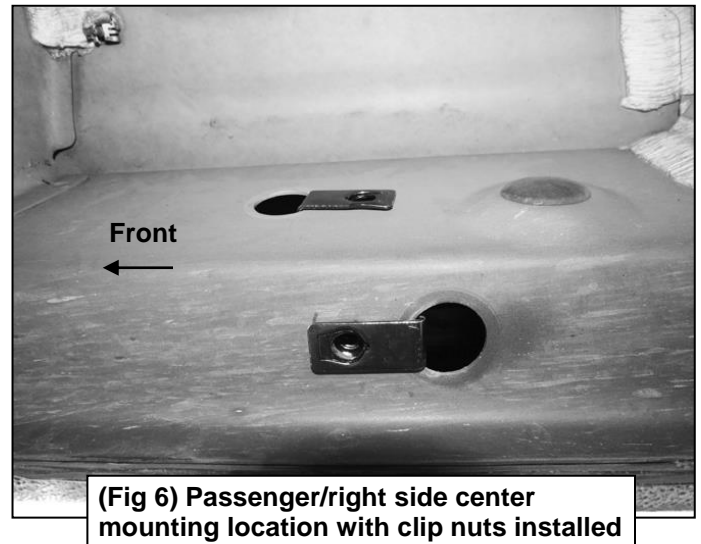
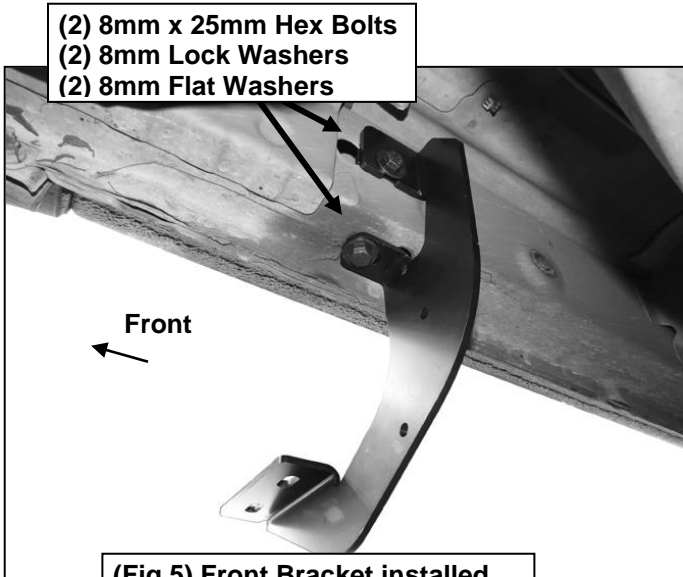
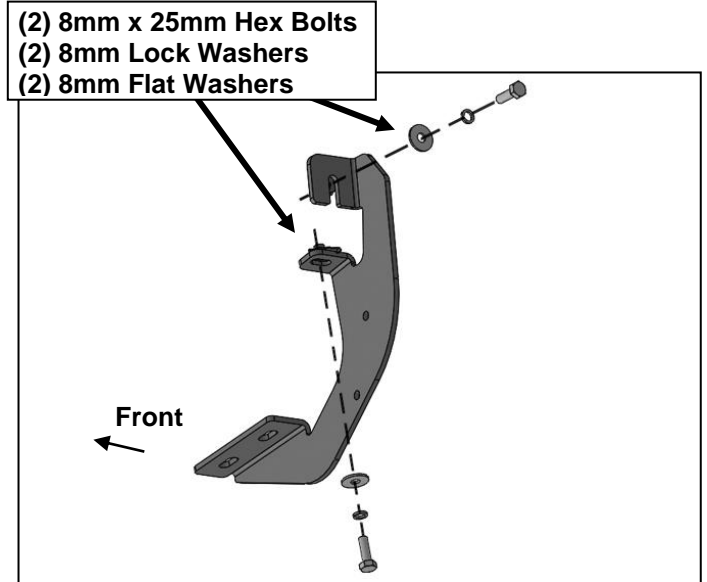
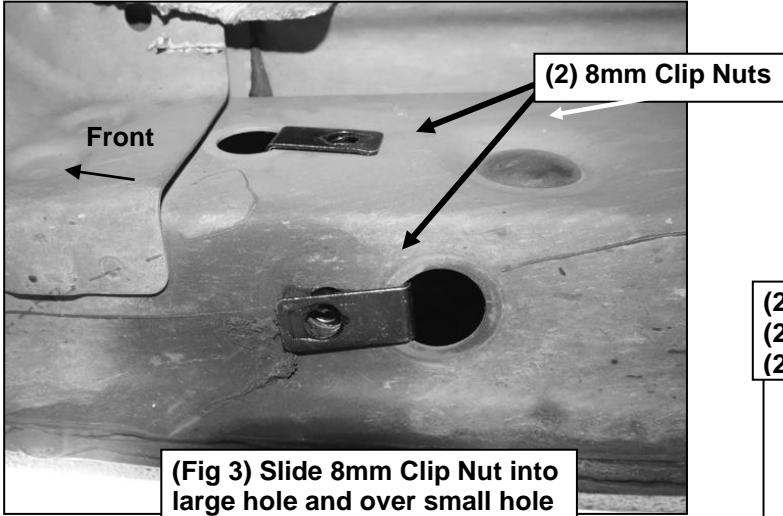

Passenger/right Side Installation Pictured

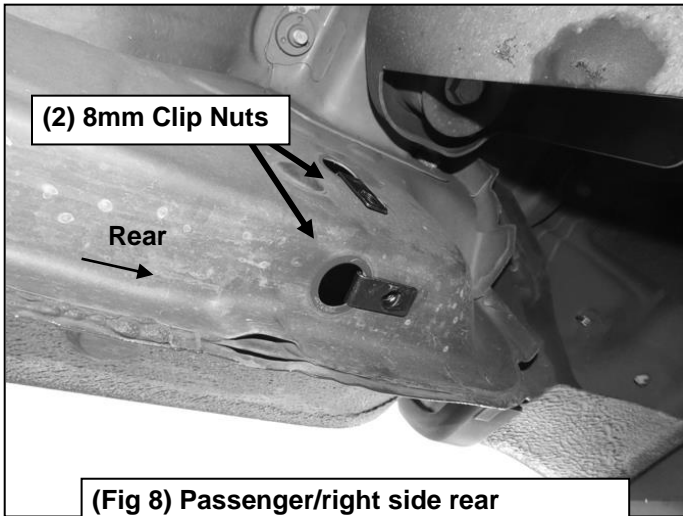

(2) 8mm Clip Nuts

Rear

(Fig 8) Passenger/right side rear mounting location with clip nuts installed

NOTE: Each Rear Bracket is unique. When installed properly, the lower Bracket flange will face towards the front while the upper flanges will face towards the rear. See (→)'s on Rear Brackets.

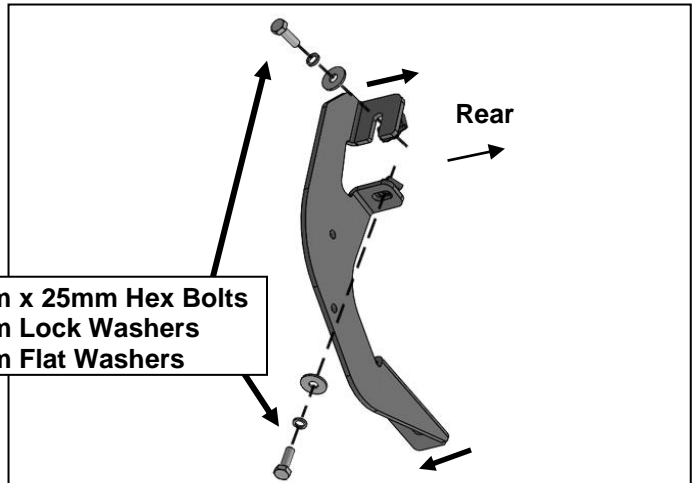

(2) 8mm x 25mm Hex Bolts
(2) 8mm Lock Washers
(2) 8mm Flat Washers

(Fig 9) Passenger side Rear Mounting Bracket

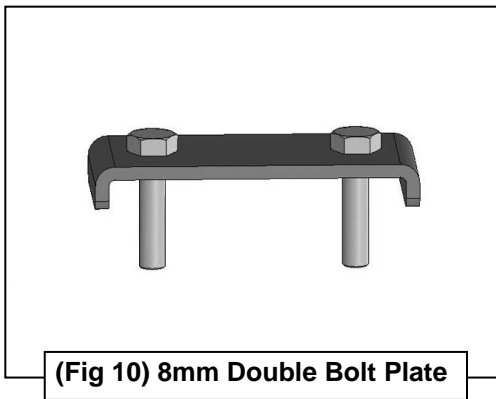

(Fig 10) 8mm Double Bolt Plate

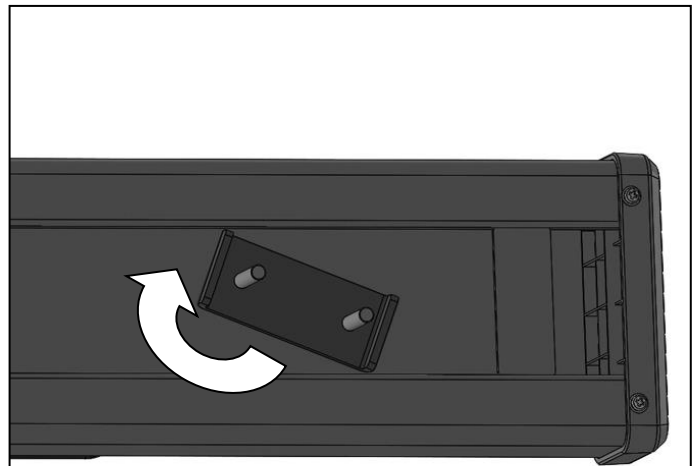

(Fig 11) Slide 8mm Double Bolt Plate into channel

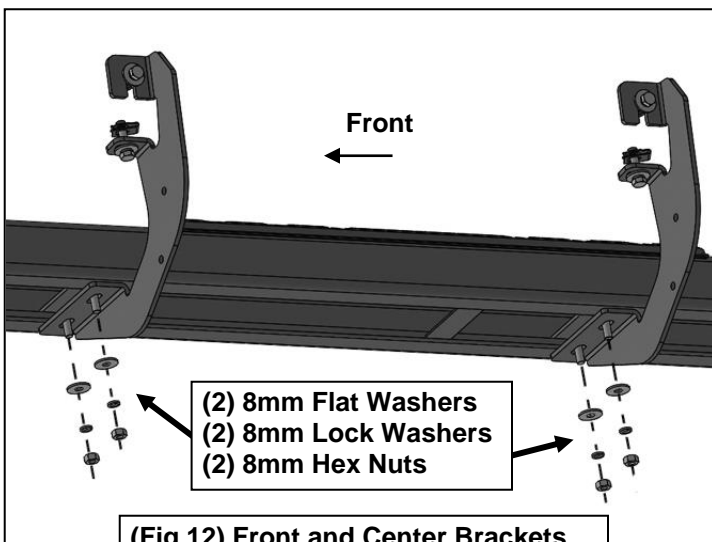

(2) 8mm Flat Washers
(2) 8mm Lock Washers
(2) 8mm Hex Nuts

(Fig 12) Front and Center Brackets attached to Passenger/right Sidebar

Passenger/right Side Installation Pictured

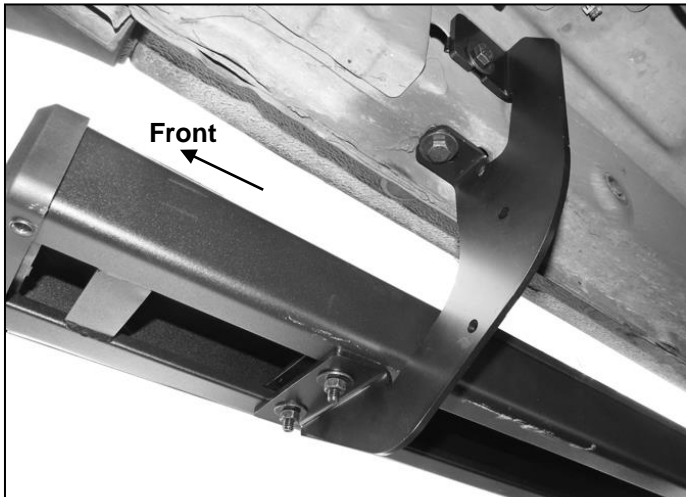

(Fig 13) Front Bracket attached to Passenger Sidebar

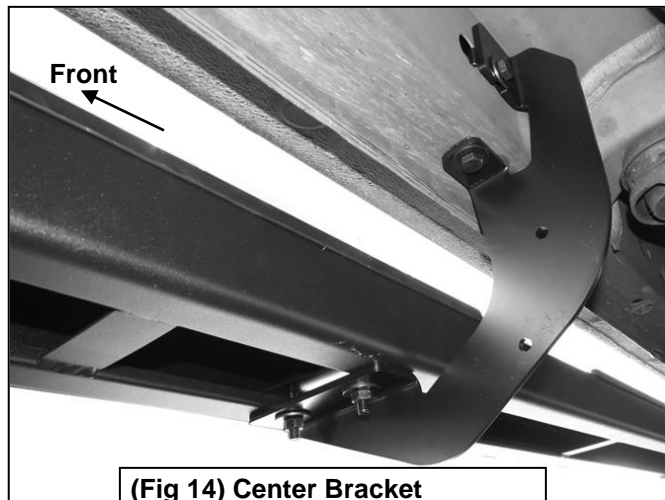

(Fig 14) Center Bracket attached to Passenger Sidebar

NOTE: Each Rear Bracket is unique. When installed properly, the lower Bracket flange will face towards the front while the upper flanges will face towards the rear. See (→)'s on Rear Brackets.

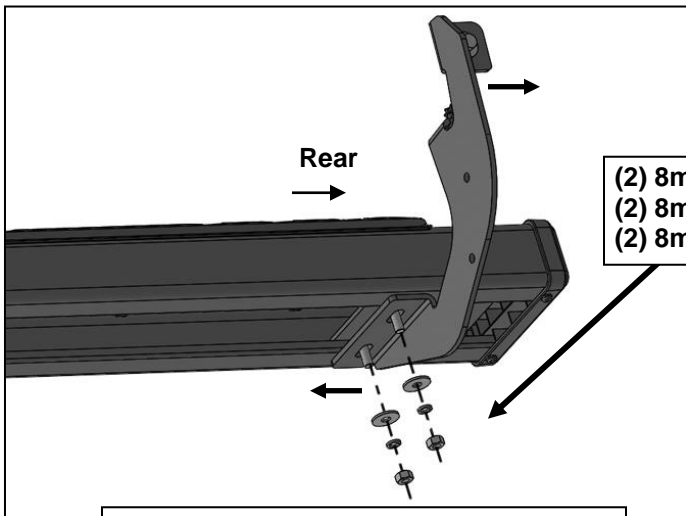

(Fig 15) Passenger side Rear Bracket attached to Passenger Sidebar



Complete Installation