

## EXTREME HD GRILLE GUARD

2009-18 DODGE RAM 1500 (19-20 Ram 1500 Classic)

**EXCLUDES WARLOCK, REBEL, SPORT MODELS WITH 1-PIECE PLASTIC BUMPER COVER**

### PARTS LIST:

1	Extreme Grille Guard	16	12mm x 32mm OD x 3mm Flat Washers
1	Driver/Left Frame Mounting Bracket	10	12mm Lock Washers
1	Passenger/Right Frame Mounting Bracket	10	12mm Hex Nuts
1	Driver/Left Upper Bracket (2009-12)	2	10-1.5mm x 40mm Hex Bolts
1	Passenger/Right Upper Bracket (2009-12)	4	10mm x 27mm OD x 3mm Flat Washers
1	Driver/Left Upper Bracket (2013-18)	2	10mm Lock Washers
1	Passenger/Right Upper Bracket (2013-18)	2	10mm Hex Nuts
1	Driver/Left Top Support Bracket	2	10mm Nut Plate
1	Passenger/Right Top Support Bracket	4	8mm x 20mm Button Head Allen Bolts
4	12-1.75mm x 60mm Gr. 10.9 Hex Bolts	4	8mm x 22mm OD x 2mm Flat Washers
6	12-1.75mm x 35mm Gr. 10.9 Hex Bolts	4	8mm Lock Washers
4	12mm x 24mm OD x 2.5mm Flat Washers	1	Allen Wrench

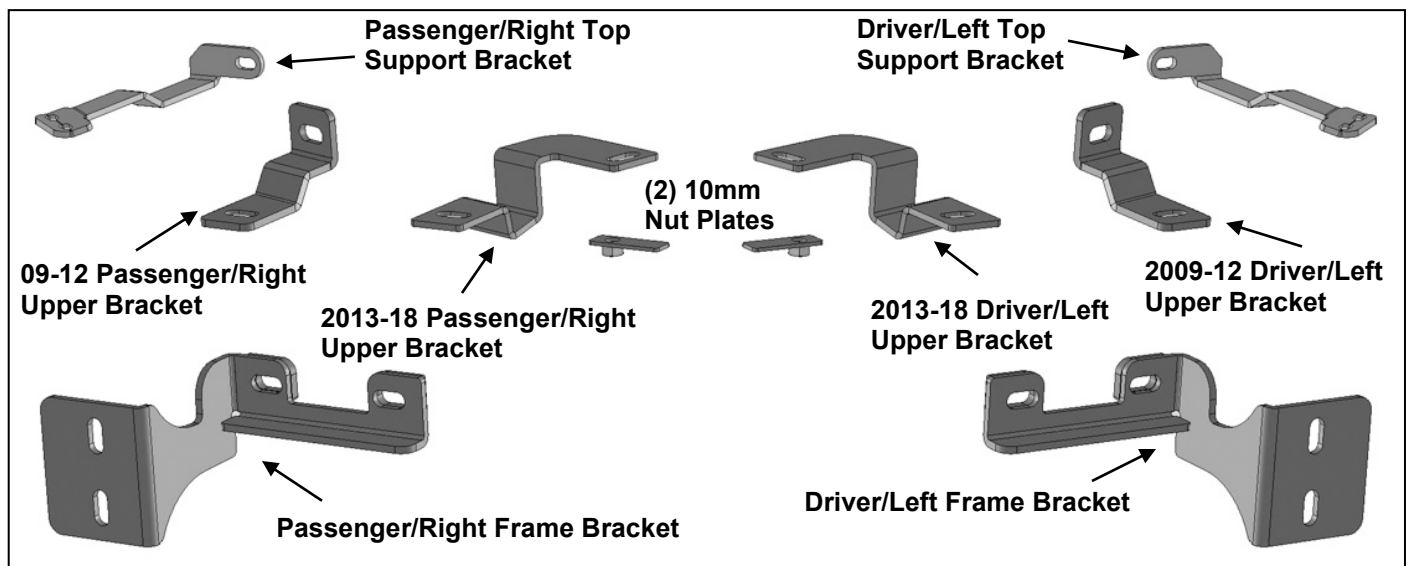

### PROCEDURE:

- REMOVE CONTENTS FROM BOX. VERIFY ALL PARTS ARE PRESENT. READ INSTRUCTIONS CAREFULLY BEFORE STARTING INSTALLATION. ASSISTANCE IS RECOMMENDED. EXCLUDES ALL MODELS WITH FULL 1-PIECE PLASTIC BUMPER COVER.**
- Determine if the vehicle is equipped with or without the factory tow hooks.
 

**On vehicles without factory tow hooks:** Remove the plastic fill panel on the front bumper by removing the 2-piece plastic clips at the top of the panel, **(Figure 1)**. **NOTE:** Use a flat-blade screwdriver to first pop the center pin out to release the clip. Next, from behind the driver side of the front bumper, remove the (2) hex nuts on the bottom of the bumper bracket securing the bumper to the frame, **(Figure 2)**.

**On vehicles with factory tow hooks:** Start the installation on the driver side, behind the front bumper. Remove the factory tow hook, **(Figure 3)**. Remove the two hex nuts on the bottom of the bumper bracket securing the 2-bolt tow hook mounting bracket to the frame.
- Next, drive the (2) carriage bolts in the bumper bracket out of the bracket by striking the end of the bolts with a hammer, **(Figure 4)**. Discard the tin retaining washers. Insert the driver side Mounting Bracket into the opening in the front of the bumper. Line up the (2) mounting holes with the holes in the bumper bracket. Insert (2) 12mm x 60mm Hex Bolts and (2) 12mm x 32mm OD Large Flat Washers through the driver side Frame Mounting Bracket and bumper bracket. Use the supplied (2) 12mm x 24mm Flat Washers, (2) 12mm Lock Washers and (2) 12mm Hex Nuts, **(Figures 5 & 6)**. Snug but do not tighten hardware.

## EXTREME HD GRILLE GUARD

2009-18 DODGE RAM 1500 (19-20 Ram 1500 Classic)

**EXCLUDES WARLOCK, REBEL, SPORT MODELS WITH 1-PIECE PLASTIC BUMPER COVER**

**On vehicles with factory tow hooks:** Reinstall the factory 2-bolt tow hook bracket and secure with the supplied (2) 12mm x 24mm Flat Washers, (2) 12mm Lock Washers and (2) 12mm Hex Nuts. Snug but do not tighten hardware at this time. Reinstall the tow hook using the factory hardware.

4. Repeat **Steps 2 & 3** to install the passenger/right Frame Bracket.
5. Next, determine the correct procedure for your model year.

### 2009-12 Models:

- a. Carefully pull up on the plastic bumper cover, (on top of the bumper), to locate the carriage bolt securing the top of the steel bumper to the inner bumper bracket. Remove the carriage bolt, (**Figures 7 & 8**). **NOTE:** Use a socket with extension to reach the hex nut on the carriage bolt from behind the bumper. Access the hex nut from above the bumper bracket, (**Figure 7**).
- b. Attach the driver side 09-12 Top Mounting Bracket to the bumper by inserting (1) 10mm x 40mm Hex Bolt and (1) 10mm Flat Washer through the Bracket and hole in the bumper, (**Figures 9 & 10**). Secure with (1) 10mm Flat Washer, (1) 10mm Lock Washer and (1) 10mm Hex Nut. Do not tighten hardware at this time.
- c. Repeat **Steps a & b** for passenger side Upper Bracket installation.

### 2013-18 Models:

- a. Remove the plastic facia cover from the top of the bumper, (**Figure 11**).
  - b. Lift up on the plastic inner cover to locate the top bumper bolt, (**Figure 14**). Remove the bolt and clip nut. Insert the driver side 2013-16 Upper Bracket between the tab on the inner bumper bracket and the top of the bumper, (**Figure 13**).
  - c. Insert (1) 10mm Nut Plate into the slot in the top of the bumper. Line up the Nut Plate with the holes in the Upper Bracket and the inner bumper bracket. Attach the Upper Bracket to the Nut Plate with (1) 10mm x 40mm Hex Bolt, (1) 10mm Lock Washer and (1) 10mm Flat Washer inserted down through the tab on the factory bumper bracket, the Upper Bracket, the bumper and into the Nut Plate, (**Figure 12—14**). Do not fully tighten at this time.
  - d. Repeat **Steps a—c** for passenger side Upper Bracket installation.
  - e. Reinstall the plastic facia cover on the top of the bumper but leave loose.
6. With assistance, position the Grille Guard up to the Frame Mounting Brackets and on top of the Upper Mounting Brackets. Use the included (4) 12mm x 35mm Hex Bolts, (8) 12mm STD Flat Washers, (4) 12mm Lock Washers and (4) 12mm Hex Nuts to attach the Grille Guard to the Frame Mounting Brackets, (**Figure 15**). Snug but do not tighten at this time.
  7. Attach the Grille Guard to the Upper Brackets using the included (2) 12mm x 35mm Hex Bolts, (4) 12mm STD Flat Washers, (2) 12mm Lock Washers and (2) 12mm Hex Nuts, (**Figures 16—19**). Snug but do not tighten hardware at this time.
  8. Next, open the hood. Locate and remove the inner top mounting screw attaching the headlight assembly to the radiator cross member, (**Figure 20**). Select the driver side Top Support Bracket. Insert the Support Bracket between the tab on the headlight and the cross member. Reuse the factory screw to attach the Support Bracket, (**Figure 21**).
  9. Line up the Support Bracket with the (2) mounting holes in the bottom of the headlight guard. Attach the Bracket to the Grille Guard with (2) 8mm Button Head Screws, (2) 8mm Lock Washers and (2) 8mm Flat washers, (**Figures 22 & 23**). Do not fully tighten at this time.
  10. Repeat **Steps 8 & 9** to attach the passenger side Top Support Bracket.
  11. With assistance, align and adjust the Grille Guard and tighten all hardware including the Top Mounting Bracket and tow hook hardware. **IMPORTANT:** On **2013-18 models**, finish reattaching the plastic facia cover to the bumper after Upper Bracket to bumper hardware has been adjusted and fully tightened.
  12. **On vehicles without factory tow hooks:** The plastic fill panel in the front bumper removed in **Step 2** may be discarded or can be reinstalled but will require cutting to clear the Frame Mounting Brackets. Once modified, use the factory hardware to reinstall.
  13. Do periodic inspections to the installation to make sure that all hardware is secure and tight.

**EXTREME HD GRILLE GUARD**

**2009-18 DODGE RAM 1500 (19-20 Ram 1500 Classic)**

**EXCLUDES WARLOCK, REBEL, SPORT MODELS WITH 1-PIECE PLASTIC BUMPER COVER**

To protect your investment, wax this product after installing. Regular waxing is recommended to add a protective layer over the finish. Do not use any type of polish or wax that may contain abrasives that could damage the finish. Mild soap may be used to clean the Grille Guard

**Driver Side Installation Pictured**

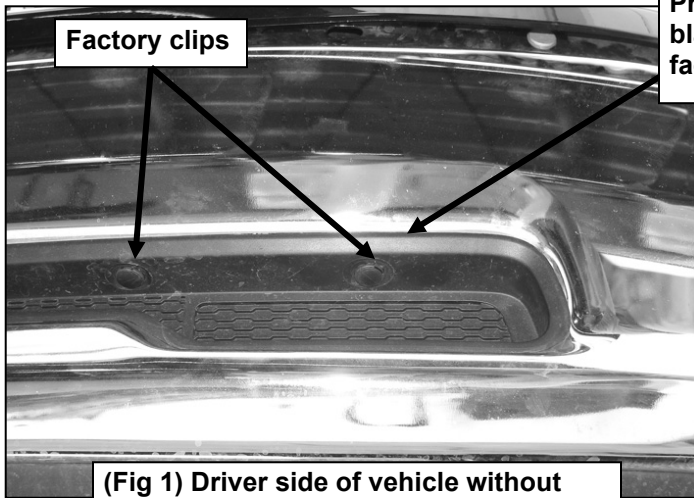

Pry up center pin with a flat blade screwdriver to release factory clip. Remove entire clip

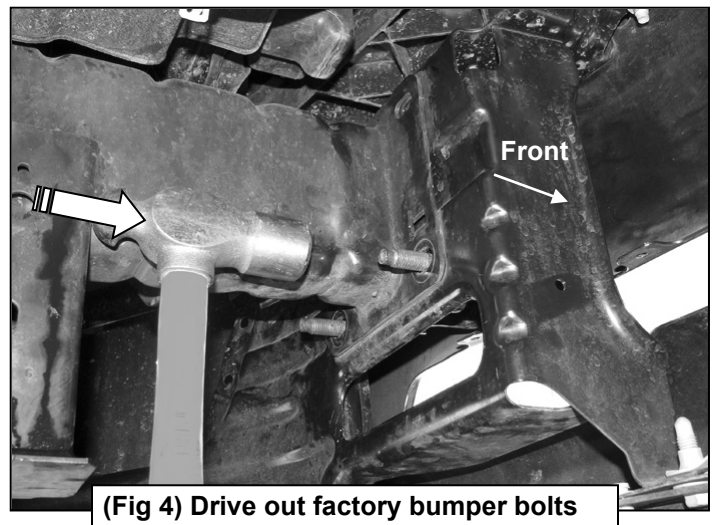
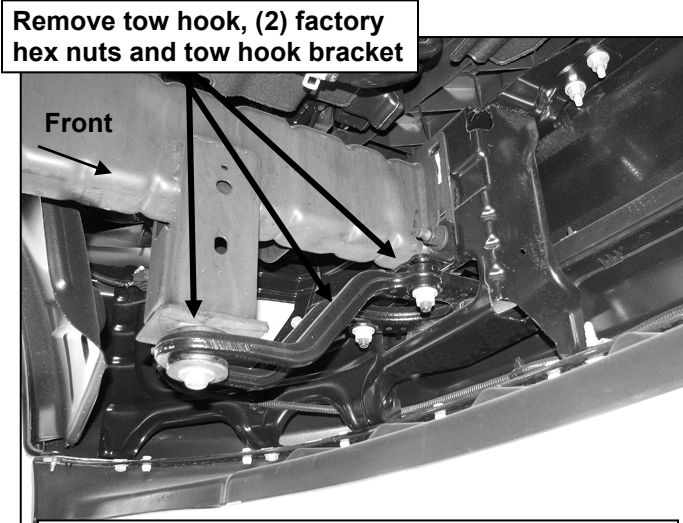
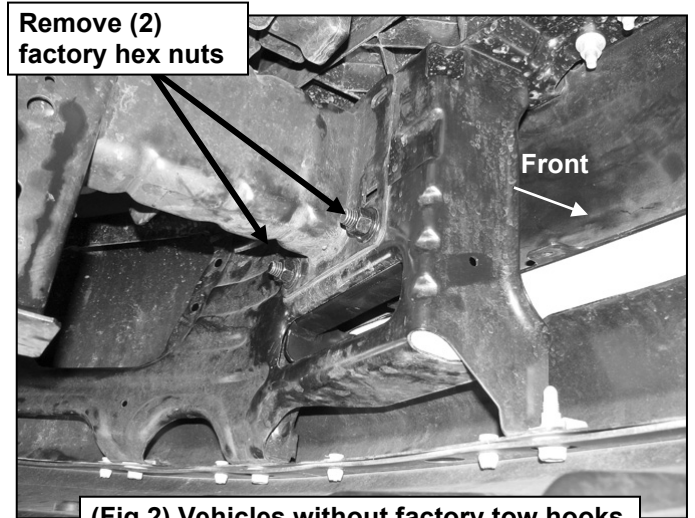

**EXTREME HD GRILLE GUARD  
2009-18 DODGE RAM 1500 (19-20 Ram 1500 Classic)  
EXCLUDES WARLOCK, REBEL, SPORT MODELS WITH 1-PIECE PLASTIC BUMPER COVER**

**Driver Side Installation Pictured**

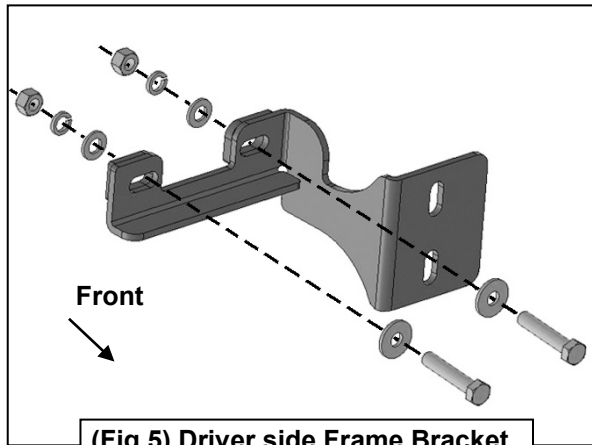

**(Fig 5) Driver side Frame Bracket**

- (2) 12mm x 60mm Hex Bolts
- (2) 12mm x 32mm Large Flat Washers (outer)
- (2) 12mm x 24mm STD Flat Washers (inner)
- (2) 12mm Lock Washers
- (2) 12mm Hex Nuts

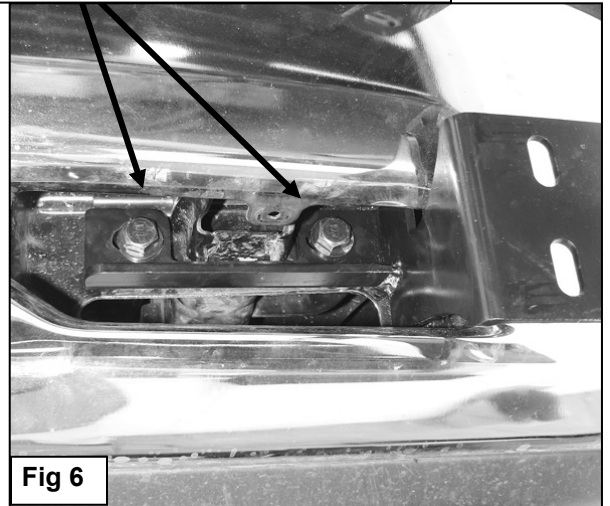

**Fig 6**

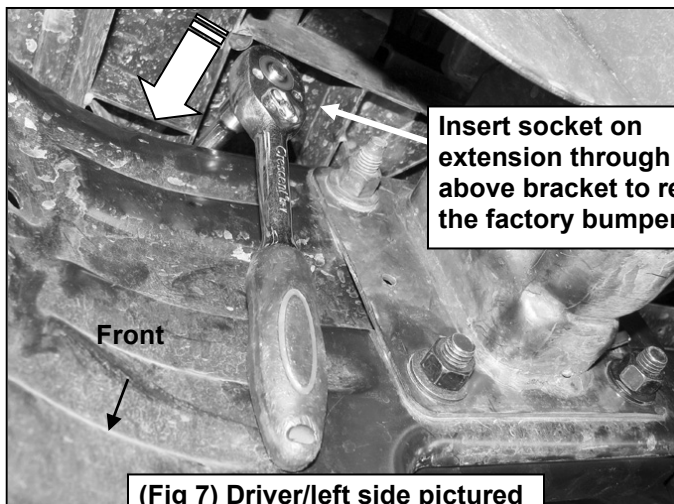

**(Fig 7) Driver/left side pictured**

Insert socket on extension through space above bracket to remove the factory bumper bolt

(2009-12) Raise plastic fascia cover to access mounting hole (factory bumper bolt removed)

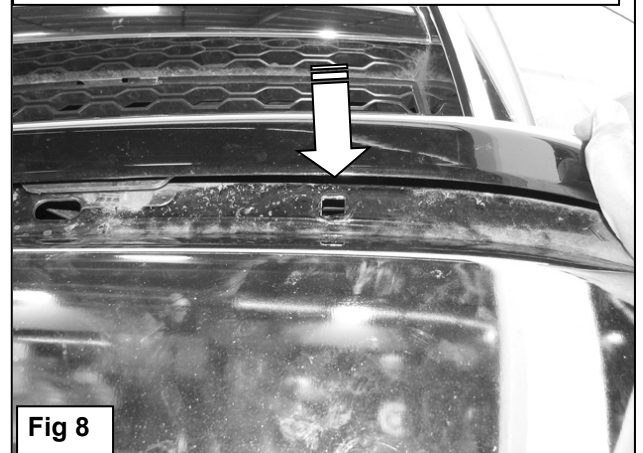

**Fig 8**

- 2009-12 models  
10mm x 40mm Hex Bolt  
(2) 10mm Flat Washers  
10mm Lock Washer  
10mm Hex Nut

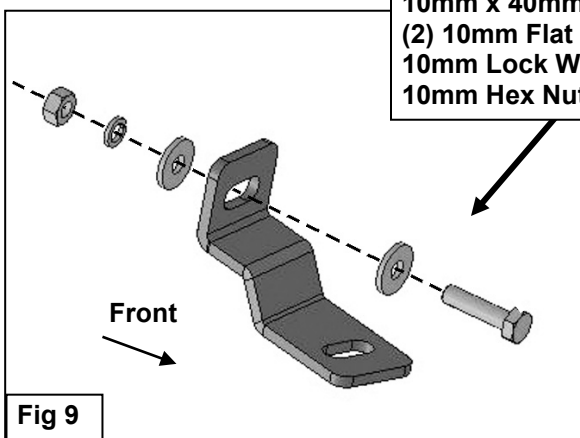

**Fig 9**

**EXTREME HD GRILLE GUARD**  
**2009-18 DODGE RAM 1500 (19-20 Ram 1500 Classic)**  
**EXCLUDES WARLOCK, REBEL, SPORT MODELS WITH 1-PIECE PLASTIC BUMPER COVER**

**Driver Side Installation Pictured**

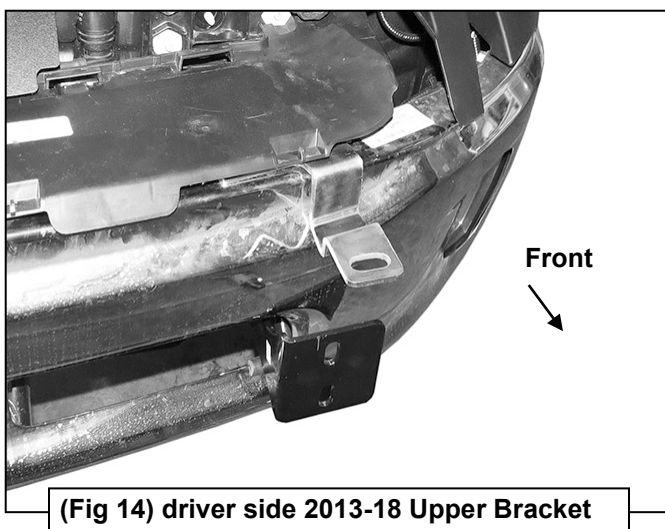
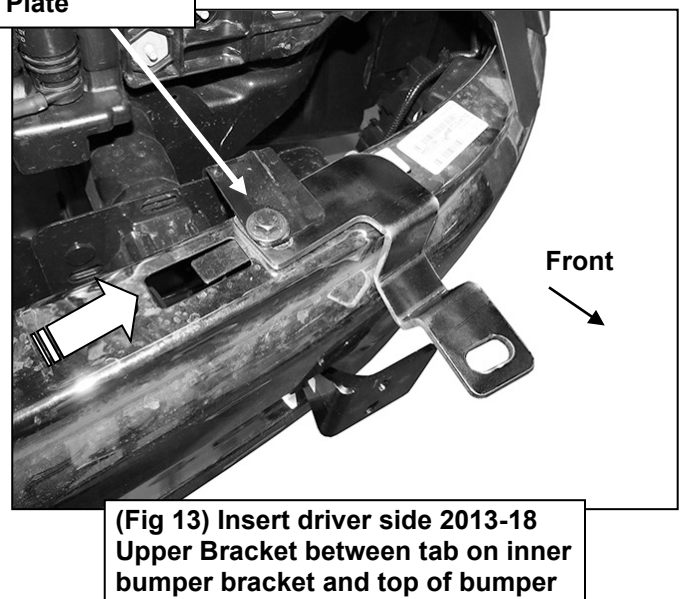
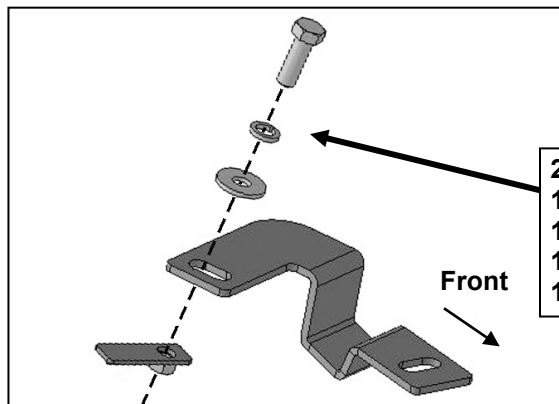
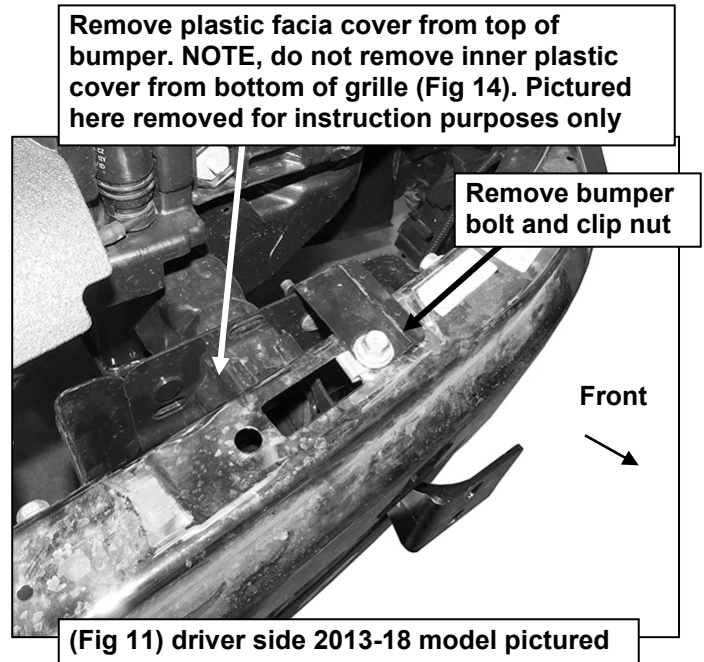
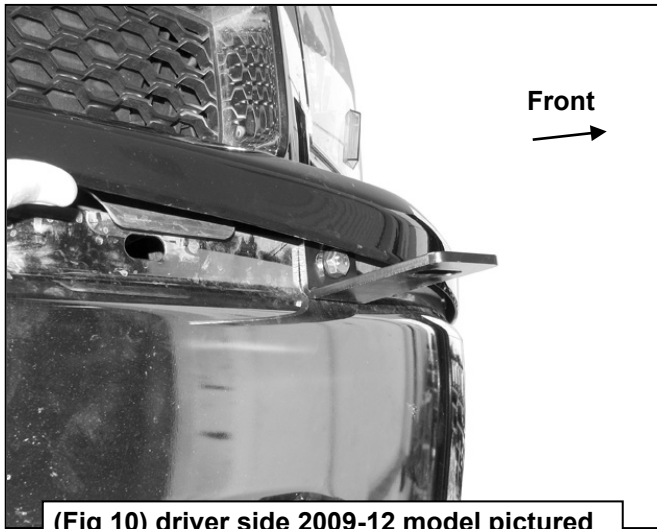

**EXTREME HD GRILLE GUARD**  
**2009-18 DODGE RAM 1500 (19-20 Ram 1500 Classic)**  
**EXCLUDES WARLOCK, REBEL, SPORT MODELS WITH 1-PIECE PLASTIC BUMPER COVER**

**Driver Side Installation Pictured**

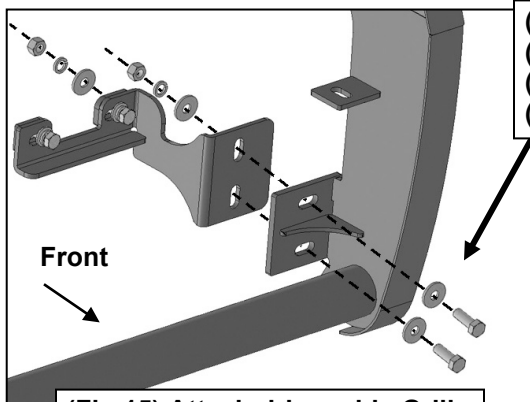

- (2) 12mm x 35mm Hex Bolts
- (4) 12mm Large Flat Washers
- (2) 12mm Lock Washers
- (2) 12mm Hex Nuts

**(Fig 15) Attach driver side Grille Guard to Frame Bracket**

- 12mm x 35mm Hex Bolt
- (2) 12mm Large Flat Washers
- 12mm Lock Washer
- 12mm Hex Nut

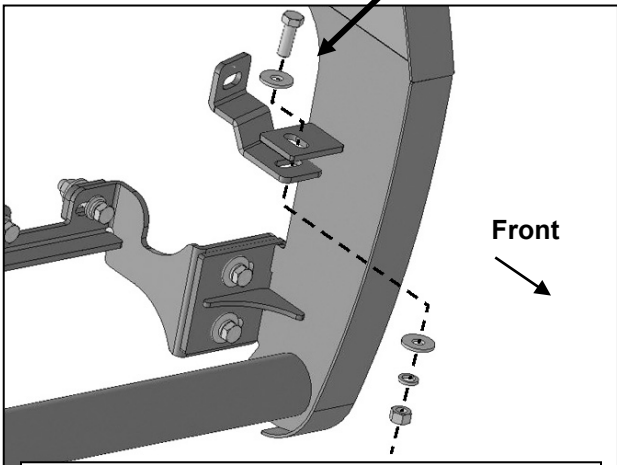

**(Fig 16) driver side 2009-12 Upper Bracket**



**(Fig 17) driver side 2009-12 installation**

- 12mm x 35mm Hex Bolt
- (2) 12mm Large Flat Washers
- 12mm Lock Washer
- 12mm Hex Nut

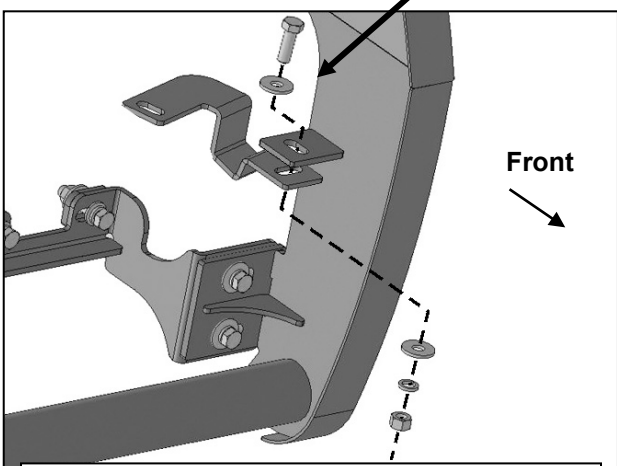

**(Fig 18) driver side 2013-18 Upper Bracket**



**(Fig 19) driver side 2013-18 installation**



**EXTREME HD GRILLE GUARD**  
**2009-18 DODGE RAM 1500 (19-20 Ram 1500 Classic)**  
**EXCLUDES WARLOCK, REBEL, SPORT MODELS WITH 1-PIECE PLASTIC BUMPER COVER**

**Driver Side Installation Pictured**

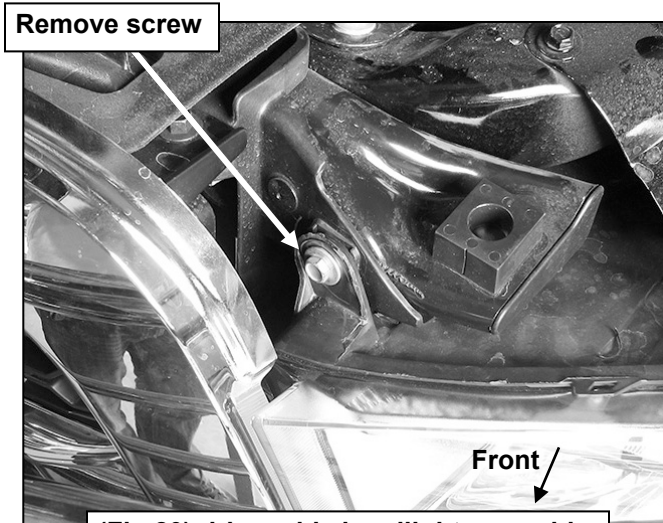

**(Fig 20) driver side headlight assembly**

Insert Support Bracket between tab on headlight assembly and cross member (arrow). Reuse factory screw to attach Bracket and headlight assembly. Do not overtighten screw

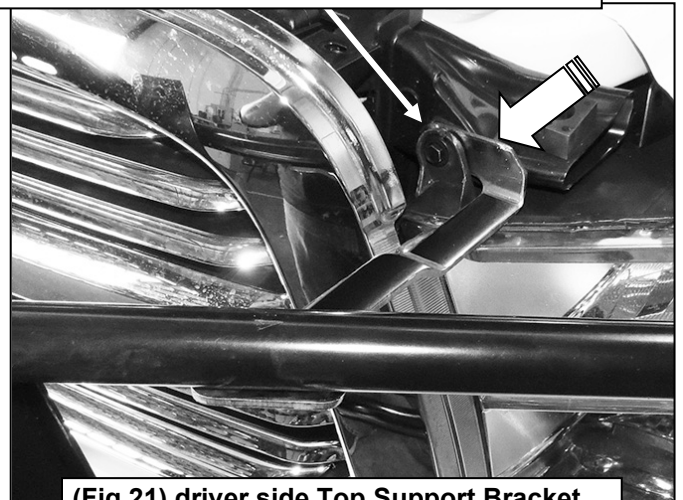

**(Fig 21) driver side Top Support Bracket**

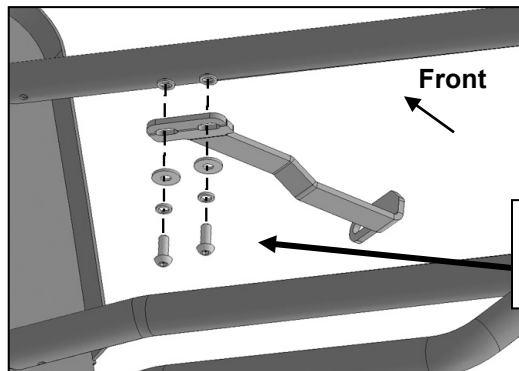

- (2) 8mm Button Head Bolts
- (2) 8mm Lock Washers
- (2) 8mm Flat Washers

**(Fig 22) driver side Top Support Bracket**

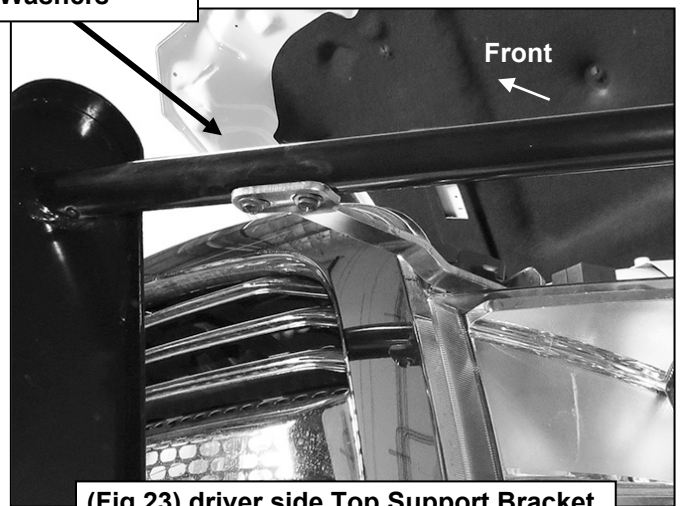

**(Fig 23) driver side Top Support Bracket**

