

**PARTS LIST:**

1	Grille Guard	2	10-1.5mm x 30mm Button Head Bolts
1	Driver/Left Side Mounting Bracket	4	10-1.5mm x 35mm Hex Bolts
1	Passenger/Right Side Mounting Bracket	4	10mm x 27mm OD x 3mm Large Flat Washers
1	Driver/Left Side Top Bracket	4	10mm x 20mm OD x 2.5mm Small Flat Washers
1	Passenger/Right Side Top Bracket	4	10mm Lock Washers
6	12-1.75mm x 35mm Hex Bolts	2	10mm Nylon Lock Nuts
12	12mm x 32mm OD x 3mm Flat Washers	4	6mm x 18mm OD x 1.6mm Flat Washers
6	12mm Lock Washers	1	50mm x 400mm Adhesive-backed Foam Tape
6	12mm Hex Nuts		

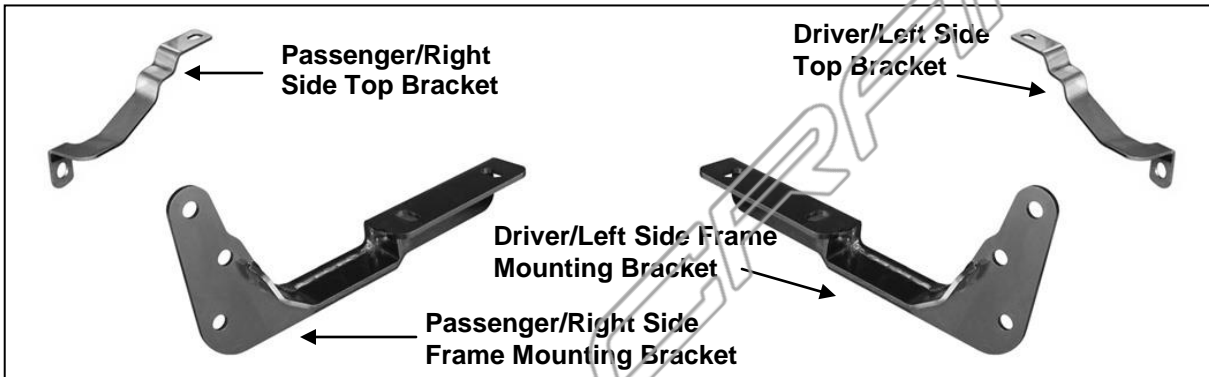

**PROCEDURE:**

- 1. REMOVE CONTENTS FROM BOX. VERIFY ALL PARTS ARE PRESENT. READ INSTRUCTIONS CAREFULLY BEFORE STARTING INSTALLATION. ASSISTANCE IS HIGHLY RECOMMENDED.**

**IMPORTANT:** This Grille Guard is not compatible with optional Adaptive Cruise Control-Forward Collision Warning Systems featuring grille mounted laser controlled speed sensor. Installation may also interfere with front bumper mounted sensor operation.

- Remove the plastic splash guard under the front bumper cover, **(Figure 1)**. Pay close attention to the type and location of all factory hardware for easier reinstallation.
- Determine if the vehicle is equipped with or without factory tow hooks, **(Figures 7 & 11A)**.
 

**2011-13 vehicles without factory tow hooks:**

  - Release the clips at the ends of the plastic bumper cover that attach the lower cover to the upper cover, **(Figure 2)**. **NOTE:** It is not necessary to remove the lower cover, only release the clips at the ends of the cover.
  - Remove the (3) large plastic clips fastening the air deflector to the bottom of the cross member, **(Figure 3)**. Carefully pull the bumper cover forward for access and pull the air deflector out from behind the bumper cover, **(Figure 4)**.
  - Release the clips securing the (2) block off covers to the ends of the air deflector, **(Figure 5)**. Remove the (2) block offs. Reinstall the air deflector using the factory hardware. Reinstall the bumper cover, **(Figure 6)**.

**2014 vehicles without tow hooks, (Figure 7):**

  - Remove the hardware attaching the bottom of the driver side front fender liner to the back of the bumper and splash guard, **(Figure 8)**.
  - Pull back the liner and reach up from behind the bumper to locate the plastic cover on each end of the lower grille, **(Figure 9)**.
  - Push to release the plastic clips on the outer edge of the cover to remove the cover from the grille opening, **(Figure 10)**.
  - Repeat this **Step** for passenger side.

**All model years equipped with tow hooks, (Figure 11A):**

- a) From under the driver side of the vehicle, locate and remove the large hex nut attaching the inner end of the driver side tow hook to the mounting bracket, **(Figures 11B & 12)**.
  - b) Remove the (2) factory hex bolts attaching the forward end of the tow hook to the bottom of the cross member and pull the tow hook out through the opening in the bumper.
  - c) Remove the (2) hex bolts attaching the mounting bracket to the bottom of the frame rail, **(Figures 13 & 14)**.
  - d) Repeat the previous Steps to remove the passenger side tow hook. **NOTE:** Tow hooks cannot be reinstalled with the Grille Guard.
4. Locate the (2) threaded holes in the bottom of the frame channel, **(Figure 15)**. Select the driver side Frame Mounting Bracket. Insert the Bracket horizontally into the opening in the bumper, **(Figure 16A)**. Rotate the Bracket up to meet the mounting location on the bottom of the frame channel, **(Figure 16B)**. Bolt the Bracket to the frame channel with (2) 10mm x 35mm Hex Bolts, (2) 10mm Lock Washers and (2) 10mm Flat Washers, **(Figure 17)**. Do not tighten hardware at this time.
  5. Repeat **Step 4** for passenger side Frame Bracket installation.
  6. With assistance, hold the Grille Guard up to the outside of the Mounting Brackets. Attach the Grille Guard to the Mounting Brackets with the included (6) 12mm x 35mm Hex Bolts, (12) 12mm Flat Washers, (6) 12mm Lock Washers and (6) 12mm Hex Nuts, **(Figure 18)**. **WARNING!** Do not allow Grille Guard to come in contact with the vehicle. Temporarily tighten hardware at this time to hold the Grille Guard in position.
  7. Open the front hood. Locate and remove the factory 6mm hex bolt on the driver side securing the plastic cover to the radiator support, **(Figure 19)**. Use the included (2) 6mm Flat Washers as spacers to fit into the recess in the plastic cover.
  8. Select the driver side Top Bracket. Apply a layer of Adhesive-backed Foam Tape to the bottom of the Top Bracket to protect the plastic cover, **(Figures 20A & 20B)**. Place the Top Bracket on top of the Washers, **(Step 7)**, and bolt it to the radiator support using the factory hex bolt, **(Figure 21)**. **NOTE:** For proper fit, the Top Brackets must fit as close to the plastic cover and the top of the grille as possible for hood closure.
  9. Line up the mounting hole in the Top Bracket with the hole in the Grille Guard upright. Bolt the Bracket to the Grille Guard with (1) 10mm x 30mm Button Head Bolt, (2) 10mm x 20mm Small Flat Washers and (1) 10mm Nylon Lock Nut, **(Figures 21 & 22)**. Do not tighten hardware at this time.
  10. Repeat **Steps 7—9** for passenger side Top Bracket installation.
  11. Align and adjust the Grille Guard and tighten all hardware.
  12. **VERY IMPORTANT: Slowly close the hood** to check for clearance between the hood and the Top Brackets. Adjust the Top Brackets as necessary for proper hood closure.
  13. Do periodic inspections to the installation to make sure that all hardware is secure and tight.

**To protect your investment**, wax this product after installing. Regular waxing is recommended to add a protective layer over the finish. Do not use any type of polish or wax that may contain abrasives that could damage the finish.

**For stainless steel:** Aluminum polish may be used to polish small scratches and scuffs on the finish. Mild soap may be used also to clean the Grille Guard.

**For gloss black finishes:** Mild soap may be used to clean the Grille Guard.

Driver Side Installation Pictured

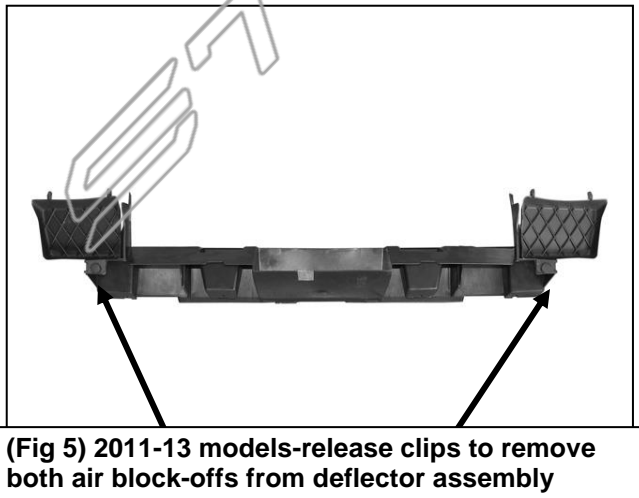
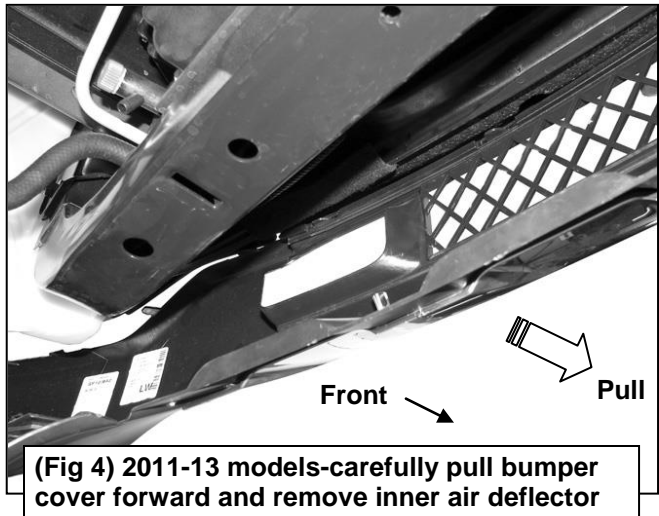
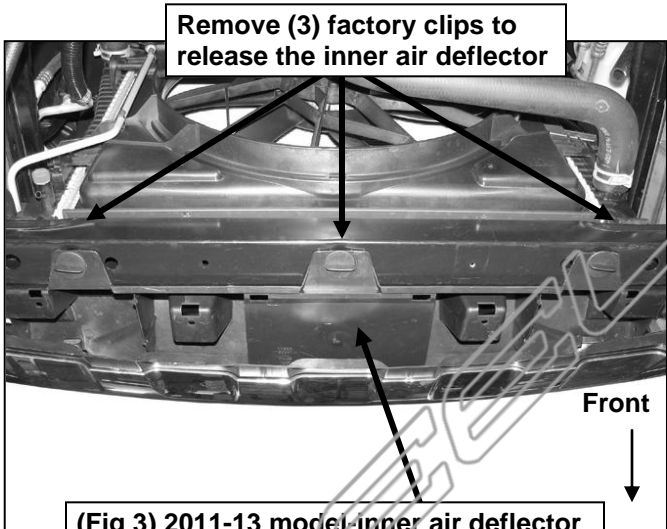
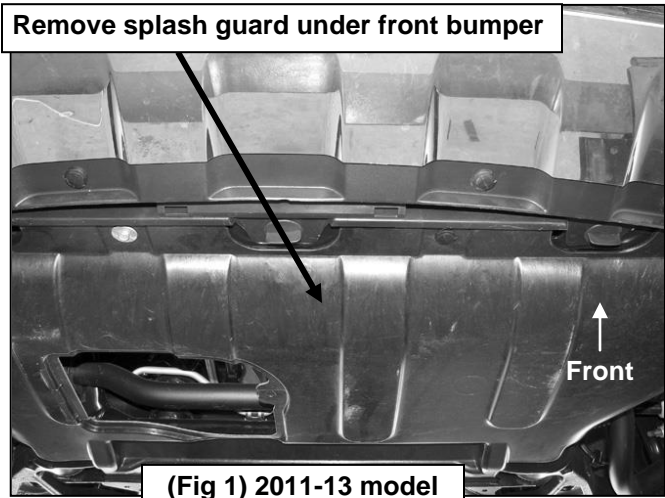

Driver Side Installation Pictured



(Fig 6) 2011-13 front bumper opening

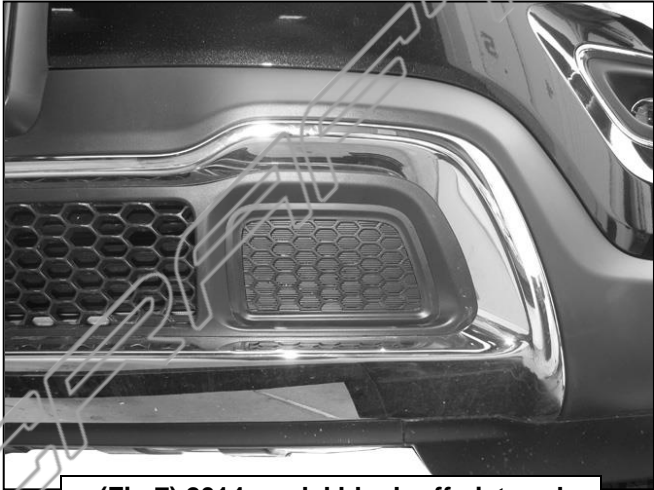

(Fig 7) 2014 model block-off pictured

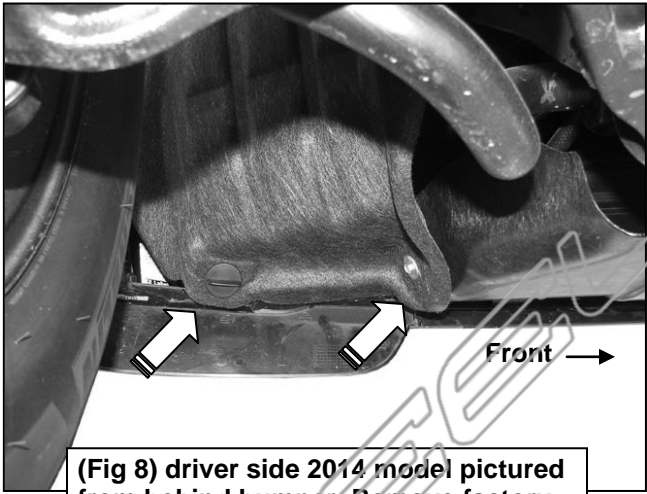

(Fig 8) driver side 2014 model pictured from behind bumper. Remove factory hardware to access mounting location

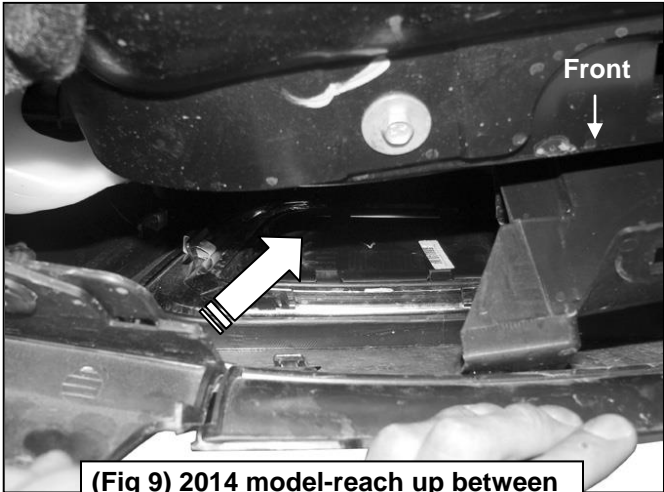

(Fig 9) 2014 model-reach up between bumper cover and radiator support to access and remove block offs

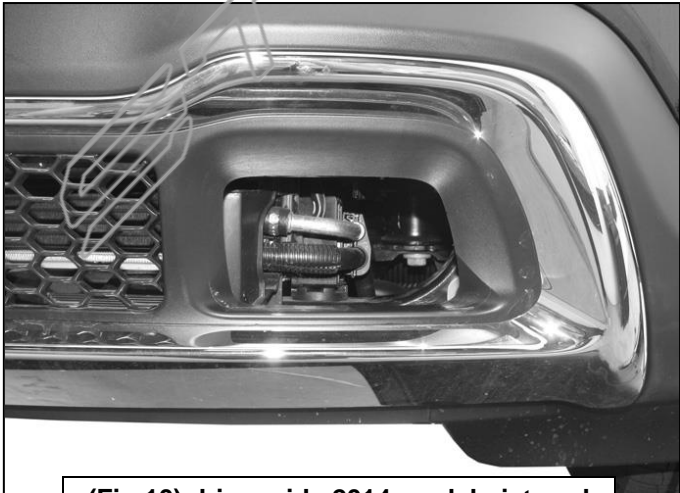

(Fig 10) driver side 2014 model pictured

Driver Side Installation Pictured



(Fig 11A) Factory tow hook pictured

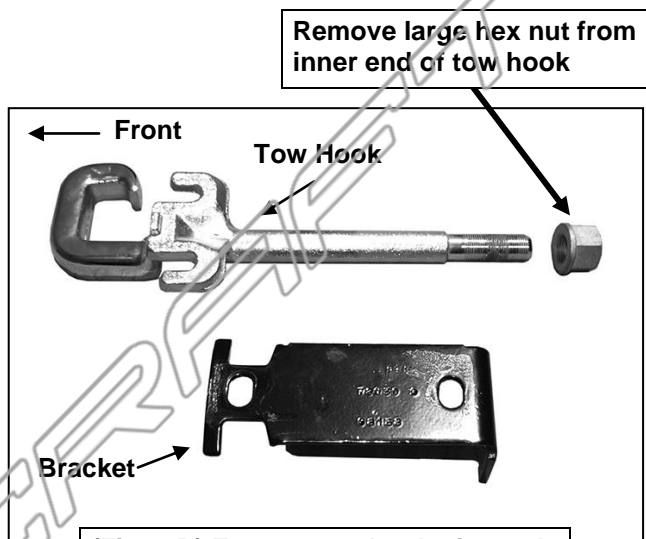

(Fig 11B) Factory tow hook pictured

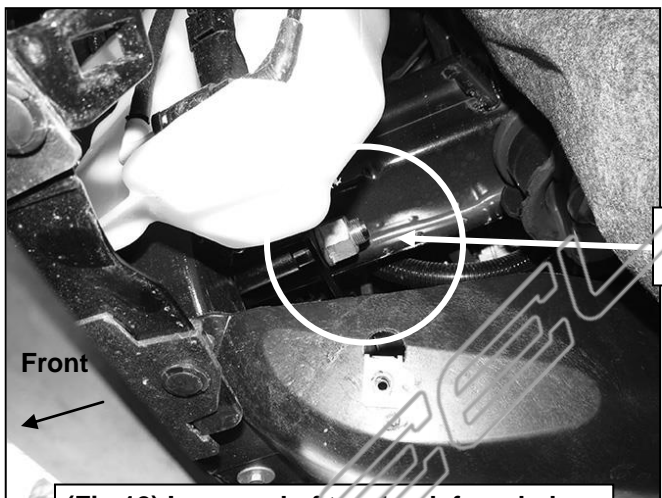

(Fig 12) Inner end of tow hook from below

Remove large hex nut from inner end of tow hook

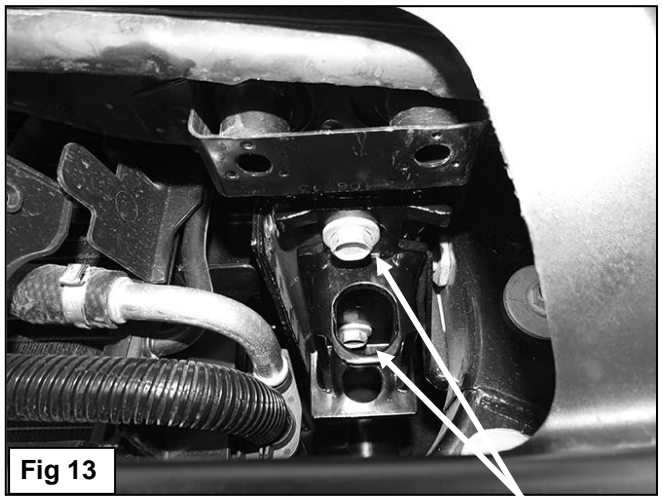

Remove (2) hex bolts to remove tow hook bracket

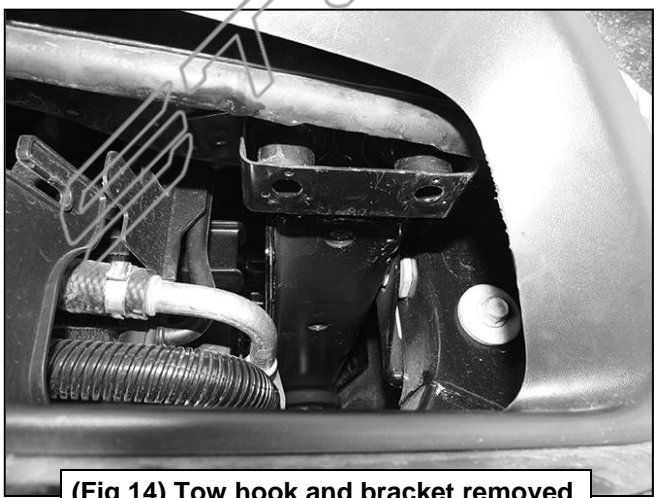

(Fig 14) Tow hook and bracket removed

Driver Side Installation Pictured

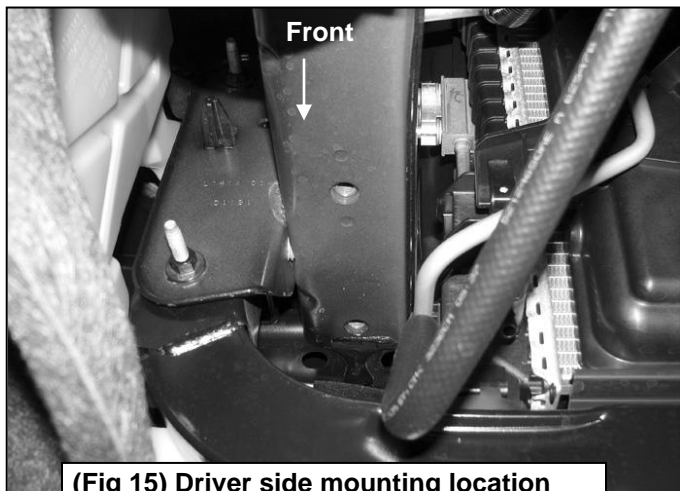

(Fig 15) Driver side mounting location pictured from below and behind bumper

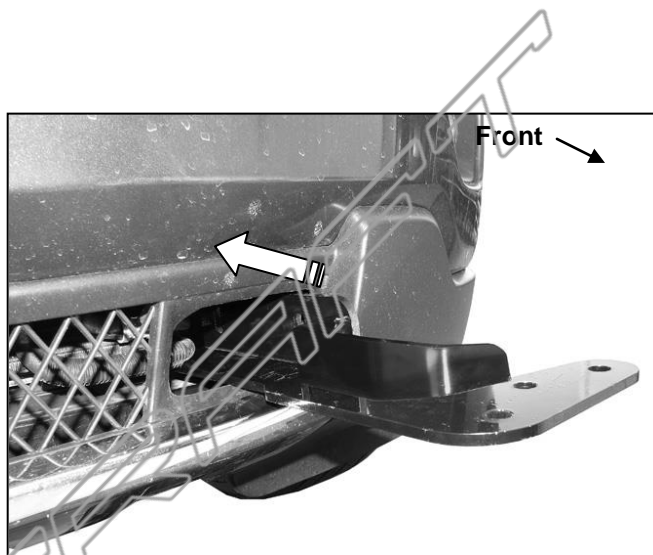

(Fig 16A) Slide Bracket into tow hook opening

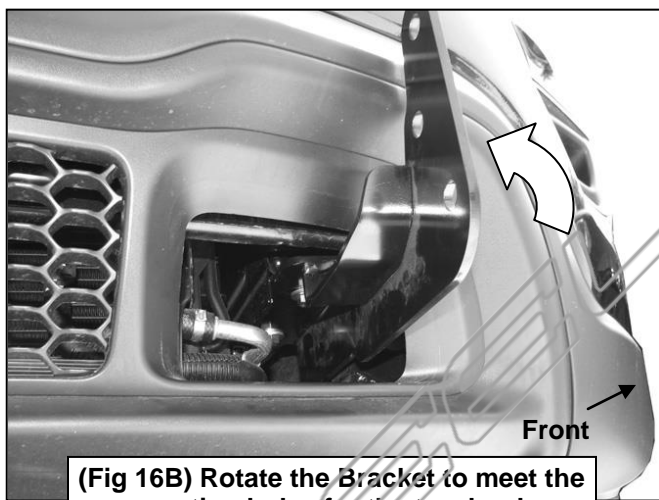

(Fig 16B) Rotate the Bracket to meet the mounting holes for the tow hooks

- (2) 10mm x 35mm Hex Bolts
- (2) 10mm Lock Washers
- (2) 10mm x 27mm Large Flat Washers

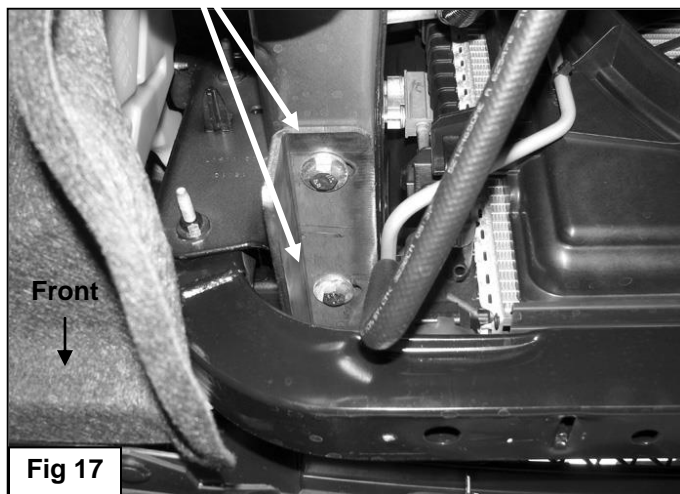

- (3) 12mm x 35mm Hex Bolts
- (3) 12mm Lock Washers
- (6) 12mm Flat Washers
- (3) 12mm Hex Nuts

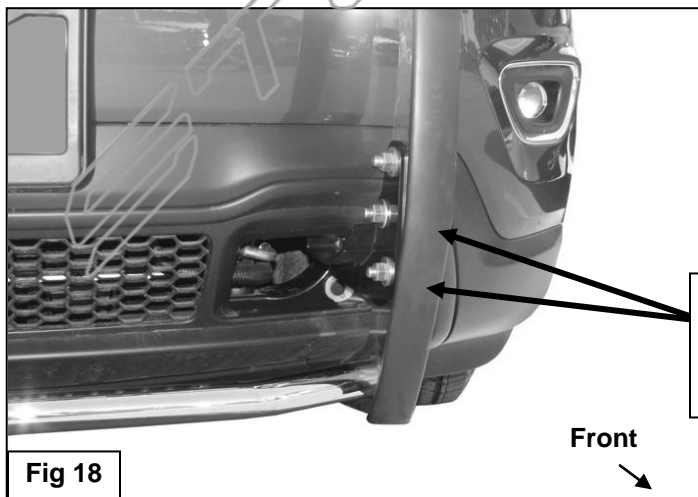

Driver Side Installation Pictured

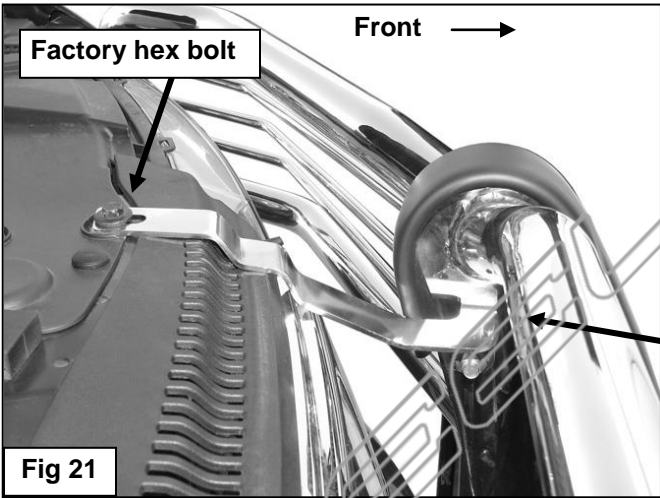
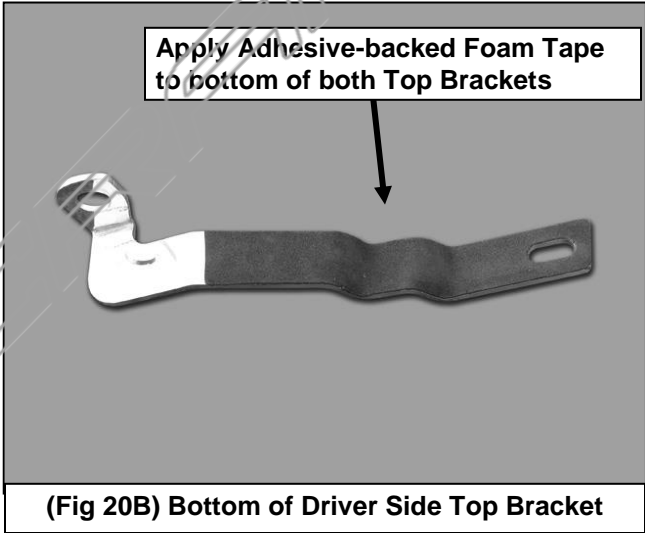
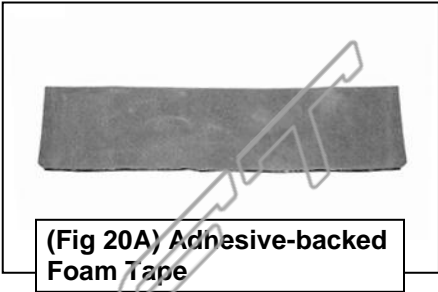
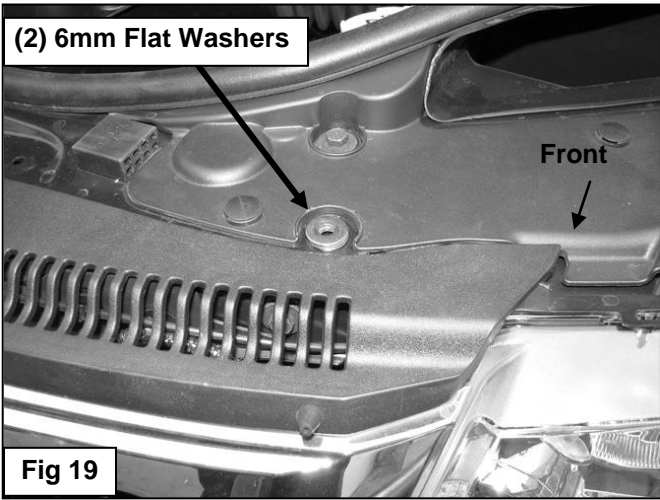

10mm x 30mm Button Head Bolt  
(2) 10mm x 20mm Small Flat Washers  
10mm Nylon Lock Nut

