

INSTALLATION INSTRUCTIONS

RATTLER STEEL RUNNING BOARDS

99-15 FORD SUPER DUTY SUPER CREW CAB

STEEL DEFLECT

PARTS LIST:

1	Driver/left Steel Running Board	6	8mm Lock Washers
1	Passenger/right Steel Running Board	6	8-1.25mm Nylon Lock Nuts
6	Universal Mounting Brackets (left of right)	6	6mm Double Bolt Plates
6	8-1.25mm Clip-Nuts	12	6mm x 22mm OD x 2mm Flat Washers
12	8-1.25mm x 25mm Hex Bolts	12	6mm Lock Washers
18	8mm x 24mm x 2mm Flat Washer	12	6mm Hex Nuts

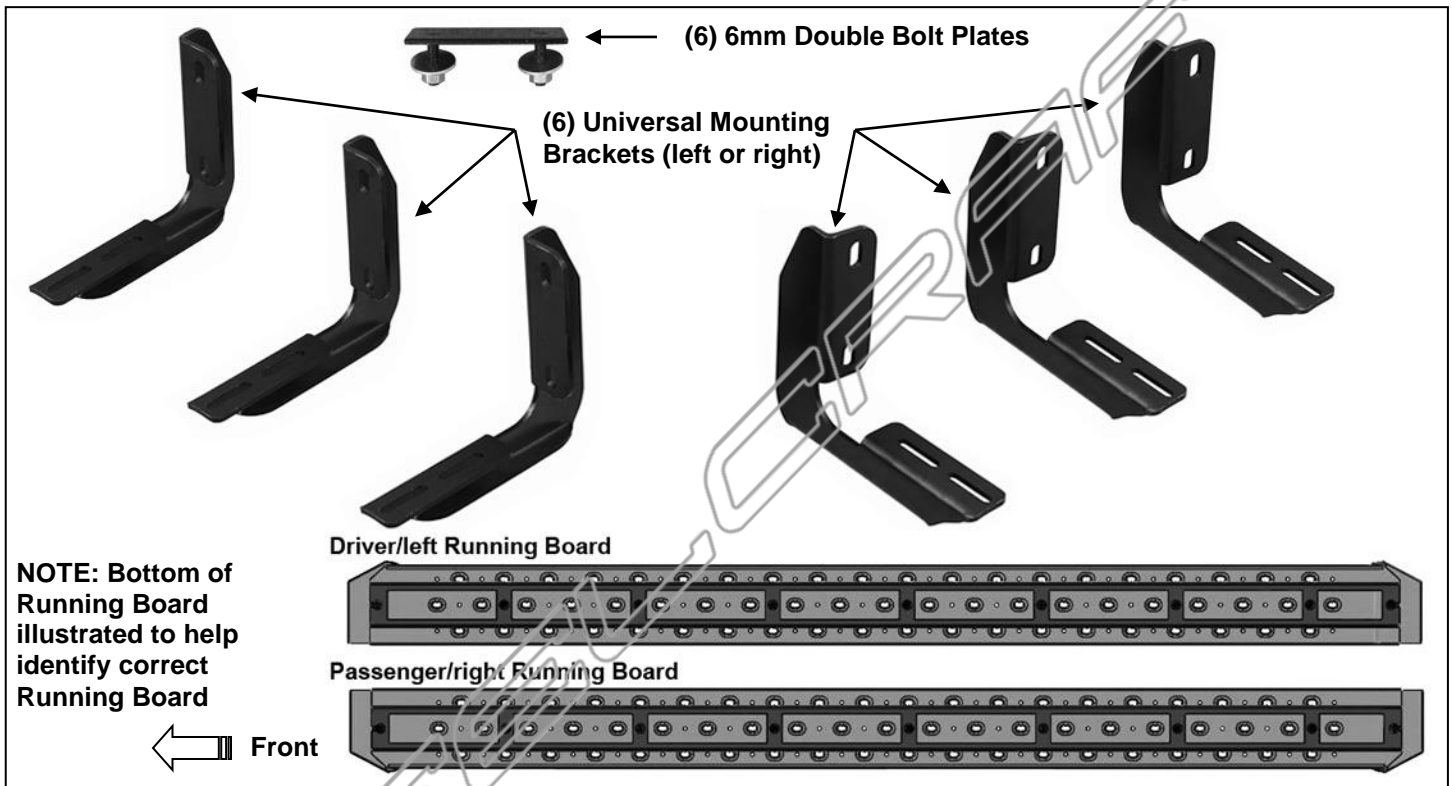

PROCEDURE:

- 1. REMOVE CONTENTS FROM BOX. VERIFY ALL PARTS ARE PRESENT. READ INSTRUCTIONS CAREFULLY BEFORE STARTING INSTALLATION.**
- Starting on the front-passenger side of the vehicle, locate the (2) holes through the bottom of the body panel, (pinch weld-**Figure 1A**). Next locate the rectangular opening and (2) small holes in the inner body panel directly above the holes in the pinch weld, (**Figures 1B & 2**). **NOTE:** The holes in the inner panel may be covered with sealing tape or insulation, remove as required.
- Slide (1) 8mm Clip Nut into the rectangular opening with the nut towards the inside. Line up the threaded nut on the clip with the round hole toward the rear, (**Figure 2**).
- Select (1) Mounting Bracket. Attach the top of the Bracket to the Clip Nut with (1) 8mm x 25mm Hex Bolt, (1) 8mm Lock Washer and (1) 8mm Flat Washer, (**Figure 3**). Leave loose at this time. Line up the lower hole in the Bracket with the hole through the pinch weld. Bolt the Bracket to the pinch weld with (1) 8mm x 25mm Hex Bolt, (2) 8mm Flat Washers and (1) 8mm Nylon Lock Nut, (**Figure 3**). Snug but do not fully tighten Bracket hardware.
- Move to the center mounting location, (**Figure 4**). **NOTE:** There are (5) factory mounting locations along the inner body panel. Installation will use the 1st, 3rd and 5th mounting locations only. Refer to **Figures 1A & 1B** to help identify the correct locations. Repeat **Steps 2—4** to install the center Bracket in the forward set of mounting holes, (**Figure 5**).
- Move toward the rear of the cab. Locate the last pair of holes along the pinch weld, (**Figure 6**). Use **Figure 1B** to determine the correct mounting location for the rear Bracket. Repeat **Steps 2—4** to install (1) Mounting Bracket in the forward pair of holes in the rear location, (**Figure 7**).

7. Once the (3) Brackets have been fully installed, select the passenger/right Running Board.
IMPORTANT: Use the illustration on **Page 1** to correctly identify the Running Boards. Place the Running Board on top of the Brackets. Locate the channels in the bottom of the Running Board. Select (3) 6mm Double Bolt Plates, (**Figure 8**). Insert the Bolt Plates into the channels in the bottom of the Running Board closest to the Brackets, (**Figure 9**). Lift the Board up and guide the studs through the Brackets.
8. Attach the Running Board to the Brackets with (6) 6mm Flat Washers, (6) 6mm Lock Washers and (6) 6mm Hex Nuts, (**Figures 10 & 11**). **NOTE:** The Running Board is designed to fit close to the vehicle. It may be necessary to loosen the Bracket hardware slightly and tilt the Brackets downward to insert the Running Board between the Brackets and the body.
9. Level and adjust the Running Board as necessary and fully tighten all hardware.
10. Repeat **Steps 2—9** for the driver side Running Board installation.
11. Do periodic inspections to the installation to make sure that all hardware is secure and tight.

To protect your investment, wax this product after installing. Regular waxing is recommended to add a protective layer over the finish. Do not use any type of polish or wax that may contain abrasives that could damage the finish. Mild soap may be used to clean the Running Board.

Passenger/right Side Installation Pictured

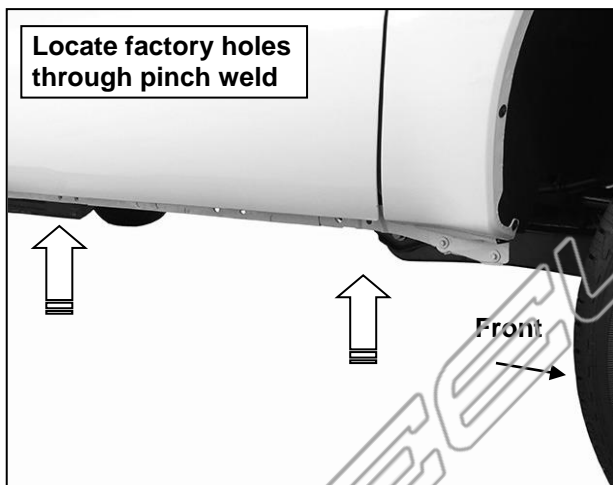

(Fig 1A) Passenger/right front and center locations

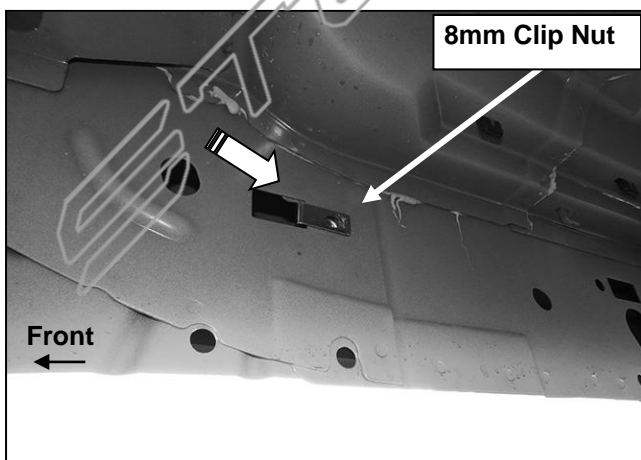

(Fig 2) Slide 8mm Clip Nut into rectangular opening

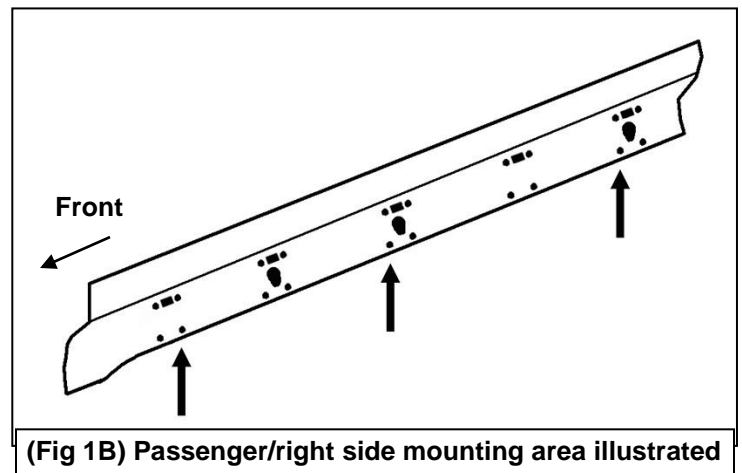

(Fig 1B) Passenger/right side mounting area illustrated

Passenger/right Side Installation Pictured



8mm Clip Nut
8mm x 25mm Hex Bolt
8mm Lock Washer
8mm Flat Washer

(Fig 3) Passenger/right front Bracket installed

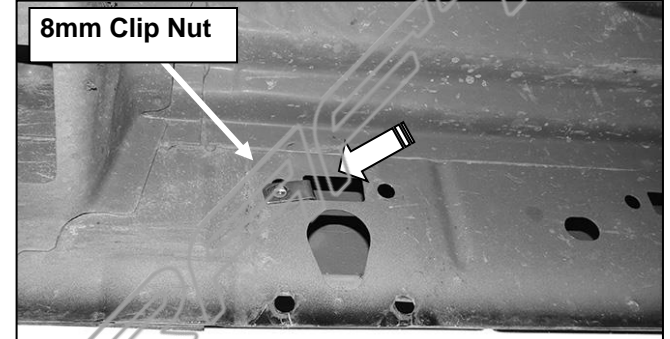

8mm Clip Nut

(Fig 4) Passenger/right center location

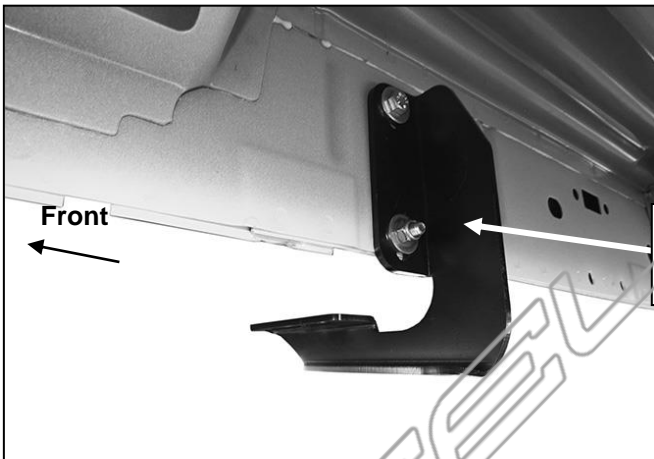

8mm x 25mm Hex Bolt
(2) 8mm Flat Washers
8mm Nylon Lock Nut

(Fig 5) Passenger/right center Bracket installed

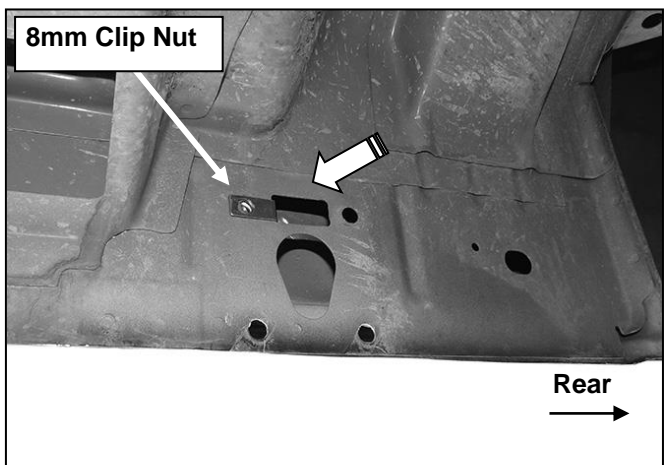

8mm Clip Nut

(Fig 6) Passenger/right rear mounting location



8mm Clip Nut
8mm x 25mm Hex Bolt
8mm Lock Washer
8mm Flat Washer

8mm x 25mm Hex Bolt
(2) 8mm Flat Washers
8mm Nylon Lock Nut

(Fig 7) Passenger/right rear Bracket installed

Passenger/right Side Installation Pictured



(Fig 8) 6mm Double Bolt Plate

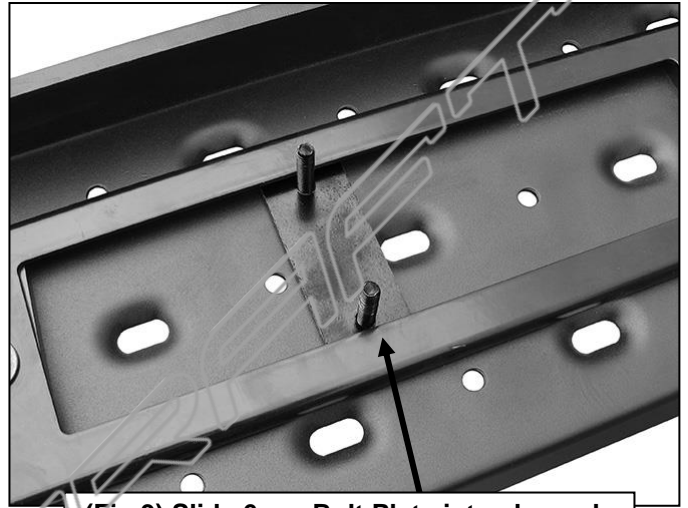

(Fig 9) Slide 6mm Bolt Plate into channels



Front
←

- (2) 6mm Flat Washers
- (2) 6mm Lock Washers
- (2) 6mm Hex Nuts

(Fig 10) Passenger/right front Bracket installed

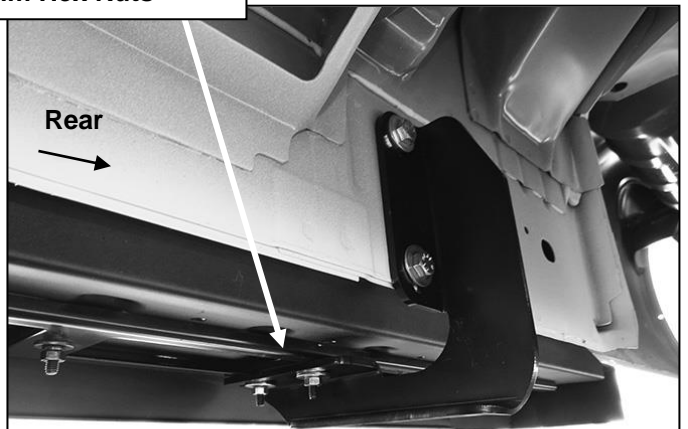

Rear
→

(Fig 11) Passenger/right rear Bracket installed



Complete Installation