

INSTALLATION INSTRUCTIONS

**RATTLER STEEL RUNNING BOARDS
99-15 FORD SUPER DUTY REGULAR CAB**

STEELCRAFT

PARTS LIST:

2	Steel Running Boards	4	8-1.25mm Nylon Lock Nuts
4	Universal Mounting Brackets (left of right)	4	6mm Double Bolt Plates
4	8-1.25mm Clip-Nuts	8	6mm x 22mm OD x 2mm Flat Washers
8	8-1.25mm x 25mm Hex Bolts	8	6mm Lock Washers
12	8mm x 24mm x 2mm Flat Washer	8	6mm Hex Nuts
4	8mm Lock Washers		

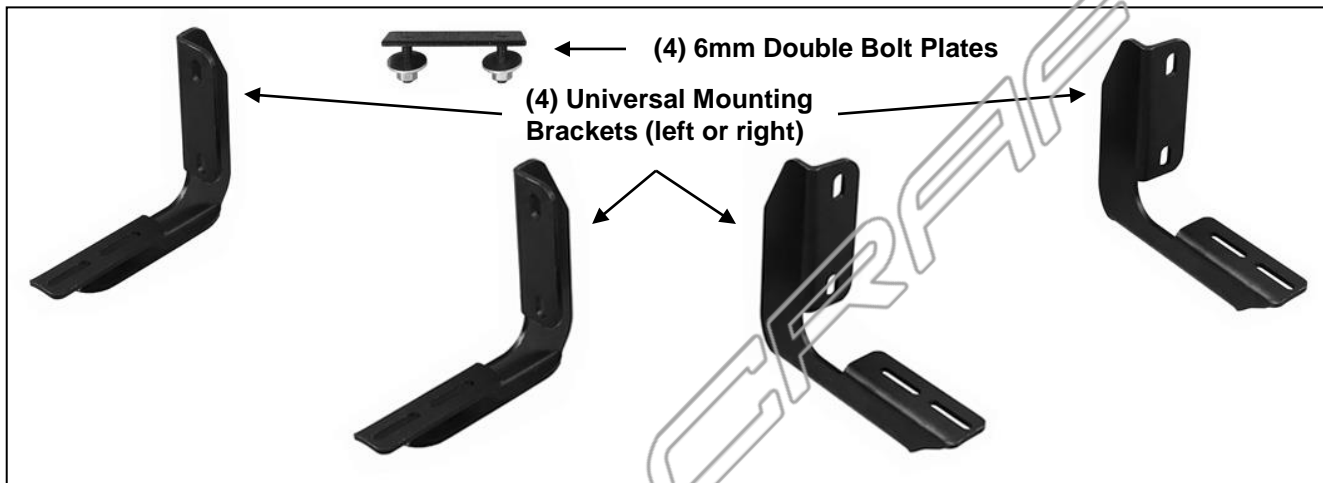

PROCEDURE:

- 1. REMOVE CONTENTS FROM BOX. VERIFY ALL PARTS ARE PRESENT. READ INSTRUCTIONS CAREFULLY BEFORE STARTING INSTALLATION.**
- Starting on the front-passenger side of the vehicle, locate the (2) holes through the bottom of the body panel, (pinch weld). Next locate the rectangular opening and (2) small holes in the inner body panel directly above the holes in the pinch weld, **(Figures 1A & 1B)**. **NOTE:** The holes in the inner panel may be covered with sealing tape or insulation, remove as required.
- Slide (1) 8mm Clip Nut into the rectangular opening with the nut towards the inside. Line up the threaded nut on the clip with the round hole toward the rear, **(Figure 2)**.
- Select (1) Mounting Bracket. Attach the top of the Bracket to the Clip Nut with (1) 8mm x 25mm Hex Bolt, (1) 8mm Lock Washer and (1) 8mm Flat Washer, **(Figures 3 & 6)**. Leave loose at this time. Line up the lower hole in the Bracket with the hole through the pinch weld. Bolt the Bracket to the pinch weld with (1) 8mm x 25mm Hex Bolt, (2) 8mm Flat Washers and (1) 8mm Nylon Lock Nut, **(Figures 3 & 6)**. Snug but do not fully tighten Bracket hardware.
- Move toward the rear of the cab. Locate the last pair of holes along the pinch weld. See **Figure 1A** to determine the correct mounting location for the rear Bracket. Repeat **Steps 2—4** to install (1) Mounting Bracket in the forward pair of holes in the rear location, **(Figure 3)**.
- Once the (2) Brackets have been fully installed, select (1) Running Board. Place the Running Board on top of the Brackets. Locate the channels in the bottom of the Running Board. Select (2) 6mm Double Bolt Plates, **(Figure 4)**. Insert the Bolt Plates into the channels in the bottom of the Running Board closest to the Brackets, **(Figure 5)**. Lift the Board up and guide the studs through the Brackets.
- Attach the Running Board to the Brackets with (4) 6mm Flat Washers, (4) 6mm Lock Washers and (4) 6mm Hex Nuts, **(Figure 6)**. **NOTE:** The Running Board is designed to fit close to the vehicle. It may be necessary to loosen the Bracket hardware slightly and tilt the Brackets downward to insert the Running Board between the Brackets and the body.
- Level and adjust the Running Board as necessary and fully tighten all hardware.
- Repeat **Steps 2—8** for driver side Running Board installation.
- Do periodic inspections to the installation to make sure that all hardware is secure and tight.

To protect your investment, wax this product after installing. Regular waxing is recommended to add a protective layer over the finish. Do not use any type of polish or wax that may contain abrasives that could damage the finish. Mild soap may be used to clean the Running Board.

Passenger Side Installation Pictured

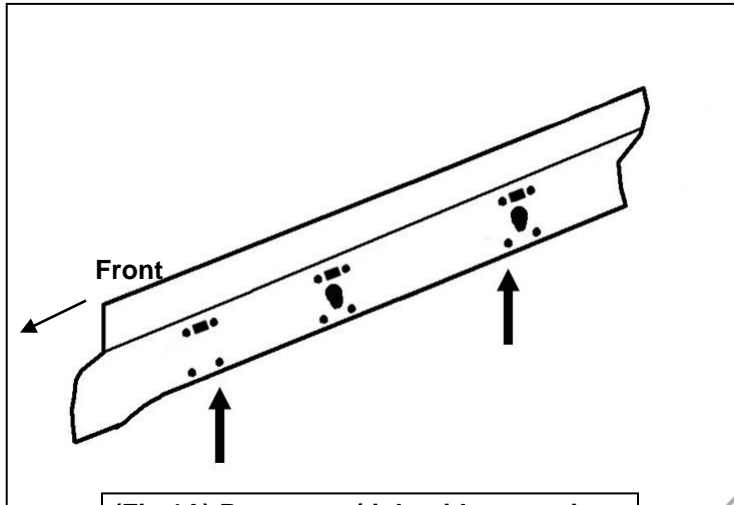

(Fig 1A) Passenger/right side mounting area illustrated for instruction purposes

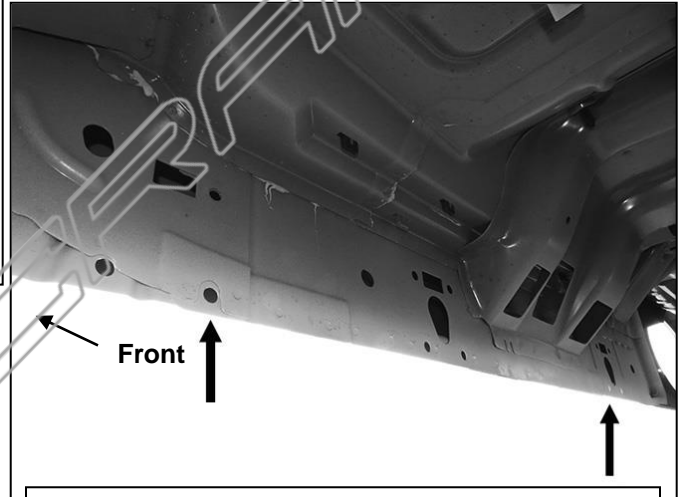

(Fig 1B) Passenger/right side mounting location

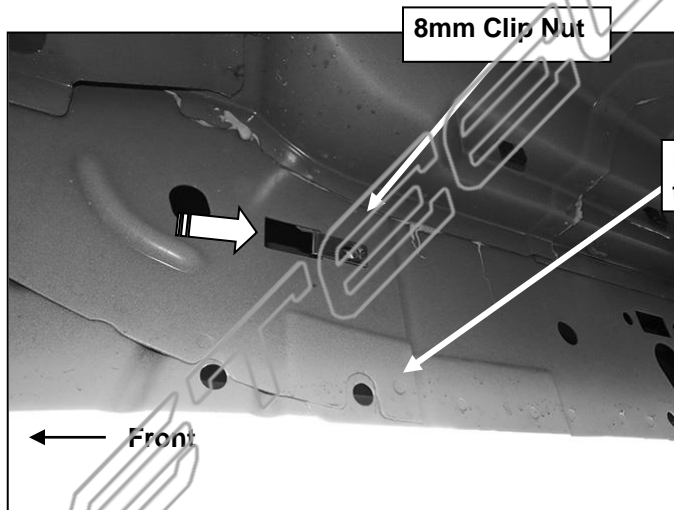

(Fig 2) Slide 8mm Clip Nut into rectangular opening

Locate factory holes through pinch weld

8mm Clip Nut
8mm x 25mm Hex Bolt
8mm Lock Washer
8mm Flat Washer

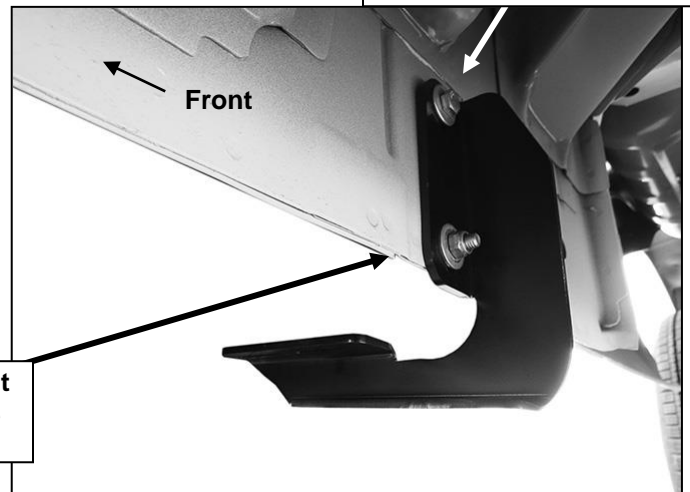

(Fig 3) Passenger/right side rear Bracket installed

8mm x 25mm Hex Bolt
(2) 8mm Flat Washers
8mm Nylon Lock Nut

Passenger Side Installation Pictured



(Fig 4) 6mm Double Bolt Plate

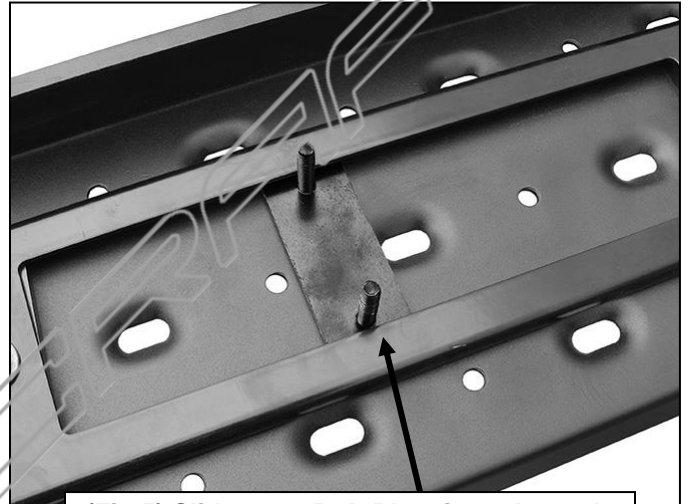

(Fig 5) Slide 6mm Bolt Plate into channels

- 8mm Clip Nut
- 8mm x 25mm Hex Bolt
- 8mm Lock Washer
- 8mm Flat Washer

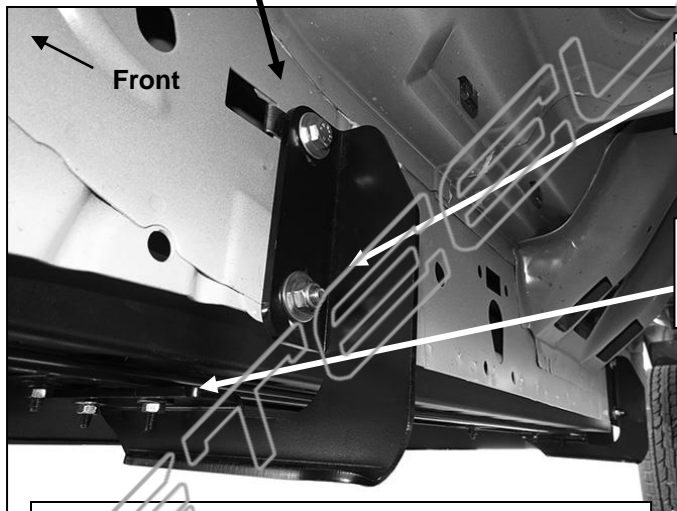

(Fig 6) Passenger side front Bracket installed

- 8mm x 25mm Hex Bolt
- (2) 8mm Flat Washers
- 8mm Nylon Lock Nut

- (2) 6mm Flat Washers
- (2) 6mm Lock Washers
- (2) 6mm Hex Nuts



Complete Installation