

INSTALLATION INSTRUCTIONS

**RATTLER STEEL RUNNING BOARDS
99-14 FORD ECONOLINE FULL SIZE VAN**

STEELCRAFT

PARTS LIST:

1	Driver/Left Side Running Board	2	10mm Lock Washers
1	Passenger/Right Side Running Board	2	10mm Hex Nuts
1	Driver/Left Side Front Bracket	1	8mm Insert Tool
1	Driver/Left Side Rear Bracket	3	8-1.25mm Inserts
1	Passenger/Right Side Front Bracket	10	8-1.25mm Clip-Nuts
1	Passenger/Right Side Center #2 Bracket	1	8-1.25mm x 40mm Hex Bolt
1	Passenger/Right Side Center #3 Bracket	10	8-1.25mm x 25mm Hex Bolts
2	Passenger/Right Side #4 & #5 Rear Brackets	11	8mm x 24mm x 2mm Flat Washers
2	12-1.75mm x 40mm Bolt Plates	10	8mm Lock Washers
2	10-1.5mm x 35mm Bolt Plates	1	8mm Hex Nut
2	12mm x 32mm OD x 3mm Flat Washers	7	6mm Double Bolt Plates
2	12mm Lock Washers	14	6mm x 22mm OD x 2mm Flat Washers
2	12mm Hex Nuts	14	6mm Lock Washers
2	10mm x 30mm OD x 2.5mm Flat Washers	14	6mm Hex Nuts

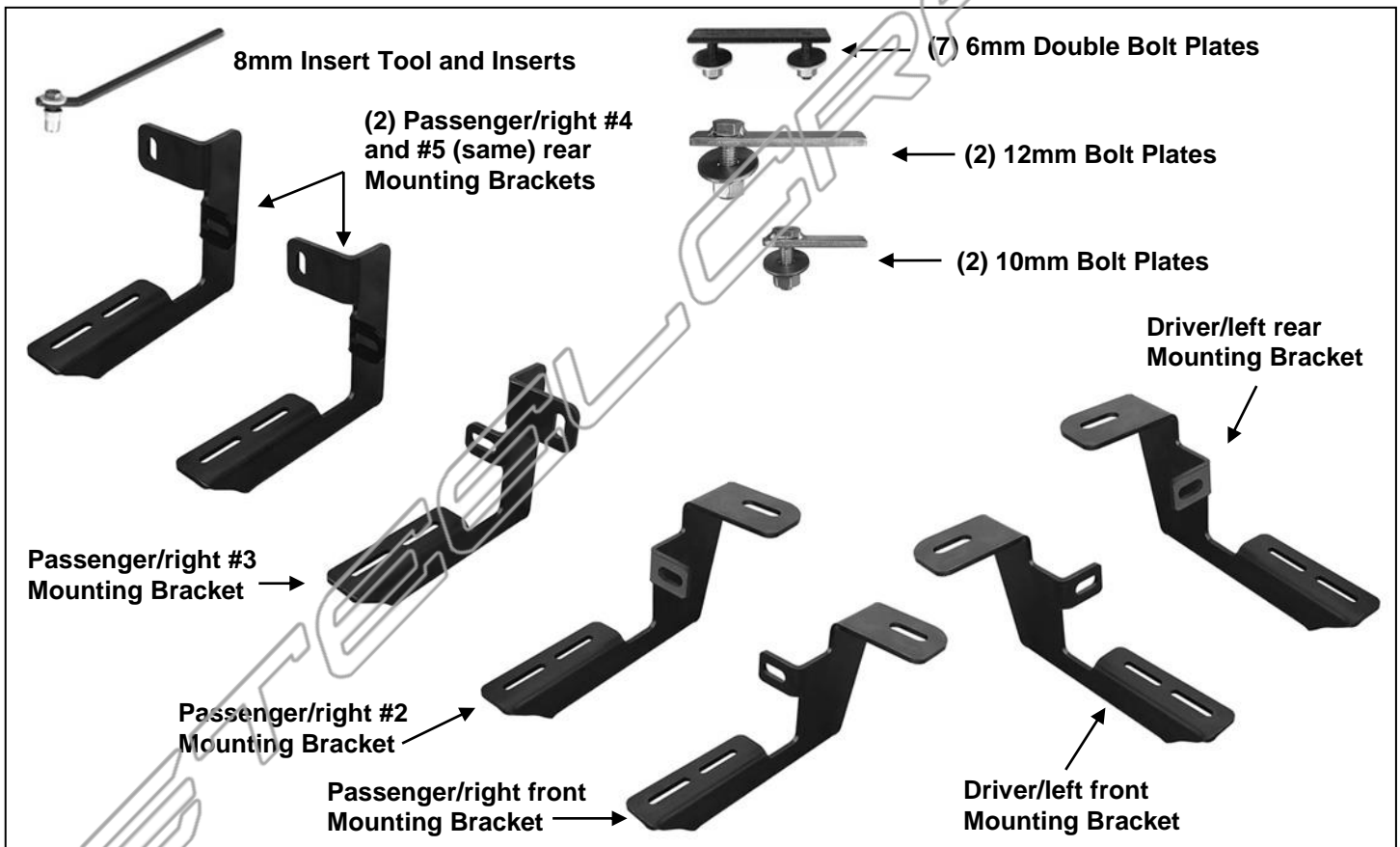

PROCEDURE:

REMOVE CONTENTS FROM BOX. VERIFY ALL PARTS ARE PRESENT. READ INSTRUCTIONS CAREFULLY BEFORE STARTING INSTALLATION. DRILLING IS REQUIRED ON 99-03 MODELS. MINOR DRILLING MAY BE REQUIRED ON ALL MODELS IF BODY PANELS DO NOT LINE UP PROPERLY.

1. Start the installation under the driver side of the vehicle. Locate and remove the rubber plug near the front tire opening, **(Figure 1)**. Select (1) 10mm Bolt Plate, **(Figure 2)**. Insert the Bolt Plate into and across the opening, **(Figures 3 and 13)**.
2. Select the driver side front Mounting Bracket, **(Figure 4)**. Attach the Bracket to the Bolt Plate with (1) 10mm Flat Washer, (1) 10mm Lock Washer and (1) 10mm Hex Nut, **(Figure 5)**. Leave hardware loose.
3. Line up the mounting tab on the Bracket with the factory hole in the pinch weld. Slide (1) 8mm Clip Nut over the hole in the pinch weld with the nut toward the outside of the vehicle, **(Figure 3)**.

IMPORTANT: On some model/years, 5/16" holes will need to be drilled through the pinch weld to attach the tab on the Mounting Bracket to the pinch weld.

- a. Line up the tab on the Bracket with a flat area on the back of the pinch weld.
- b. Fully tighten the 10mm Hex Nut on the Bolt Plate. Use the tab on the Bracket for a guide and drill a 5/16" hole through the tab and the pinch weld.

IMPORTANT! Any cutting or drilling tool may break or shatter. Government regulations require safety glasses & equipment at all times when cutting or drilling.

- c. Slide (1) 8mm Clip Nut over the hole in the pinch weld with the nut toward the outside.
4. Attach the mounting tab on the Bracket to the 8mm Clip Nut with (1) 8mm x 25mm Hex Bolt, (1) 8mm Lock Washer and (1) 8mm Flat Washer, (**Figure 5**). Snug but do not fully tighten the hardware.
5. Move along the bottom of the body to the rear bracket location, (**Figure 7**). Locate and remove the large oval rubber plug. Insert (1) 12mm Bolt Plate into the opening, (**Figures 6 & 7**).
6. Attach the driver side rear Bracket to the Bolt Plate with (1) 12mm Flat Washer, (1) 12mm Lock Washer and (1) 12mm Hex Nut, (**Figures 8 & 9**). Repeat the appropriate **Steps 3 & 4** to attach the mounting tab on the Bracket to the back of the pinch weld.
7. Select the short driver/left Running Board. Place the Running Board on top of the Brackets. Locate the channels in the bottom of the Running Board. Select (2) 6mm Double Bolt Plates, (**Figure 10**). Insert the Bolt Plates into the channels in the bottom of the Running Board closest to the Brackets, (**Figure 11**). Lift the Running Board up and guide the studs down through the Brackets. Attach the Running Board to the Brackets with (4) 6mm Flat Washers, (4) 6mm Lock Washers and (4) 6mm Hex Nuts, (**Figure 12**). **NOTE:** The Running Board is designed to fit close to the vehicle. It may be necessary to loosen the Bracket hardware and tilt the Brackets downward to insert the Running Board between the Brackets and the body. Do not tighten hardware at this time.
8. Level and adjust the Running Board forward or backward as desired and fully tighten all hardware. **NOTE:** Typical installation is with front of Board 2—3" back from front tire opening.
9. Move to the passenger side of the vehicle. Locate the rubber plug near the front tire opening, (**Figure 13**). Repeat **Steps 1—4** to install the passenger side Front Bracket, (**Figures 14 & 15**).
10. Continue along the body to the #2 Mounting Bracket location, (**Figure 16**). Repeat **Steps 5 & 6** to install the passenger side #2 Bracket, (**Figures 17 & 18**).
11. Move along the body to the #3 Bracket location below the side door, (**Figures 19 & 27**). Determine the correct procedure for your year/model for the remaining (3) passenger side Brackets:

Models with factory holes in pinch weld and inner body panel:

- a. Locate the factory hole in the pinch weld. Also locate the square hole and small round hole in the inner body panel near and above the hole in the pinch weld, (**Figure 19**). **NOTE:** Hold the appropriate Mounting Bracket up in each location to help determine the correct holes to use.
- b. Slide (1) 8mm Clip Nut into the square hole and in line with the smaller round hole. Next, slide (1) 8mm Clip Nut over the hole through the pinch weld as described in **Step 3**, (**Figure 19**).
- c. Select the passenger side #3 Mounting Bracket, (**Figure 20**). Attach the Bracket to the (2) Clip Nuts with (2) 8mm x 25mm Hex Bolts, (2) 8mm Lock Washers and (2) 8mm Flat Washers, (**Figure 21**). Do not fully tighten hardware at this time.
- d. Repeat **Steps a—c** to install the #4, (**Figure 22—24**), and #5 rear, (**Figure 25**), Brackets, (#4 and #5 locations use the same Bracket).
- e. Skip to **Step 12**.

Models without factory holes in the pinch weld and/or inner body panel:

- a. Repeat **Step 7** to attach the Running Board to the front and #2 Mounting Brackets, (**Figure 26**).
- b. Use a stand or a jack to hold the Running Board up and level with the front (2) Brackets.
- c. Select the #3 passenger side Bracket, (**Figure 20**). With the Running Board level to the vehicle, hold the Bracket up in position against the back of the pinch weld and body panel. Mark the location of the slots in the Bracket onto the sheet metal, (**Figure 27**). **NOTE:** Use a clamp or locking pliers to temporarily attach the Bracket to the pinch weld.
- d. Drill a 7/16" hole in the center of the mark for the top mounting tab. **IMPORTANT:** Make sure the Running Board is level to the vehicle before drilling any mounting holes.
- e. Select the 8mm Threaded Insert Tool, (1) 8mm x 40mm Hex Bolt, (1) 8mm Flat Washer and (1) 8mm Threaded Insert. Assemble the Insert as pictured in **Figure 30**.

- f. Firmly hold the handle and push the Insert into the hole. Use a small hammer to gently tap the insert into the hole if necessary. Once inserted, hold the handle with one hand and turn the 8mm Hex Bolt, (tighten), with a wrench to expand the insert in the body panel. Continue to tighten the hex bolt until the insert is fully compressed and close to flush with the surface. Remove bolt and tool from the insert, **(Figure 31)**. **WARNING:** Do not overtighten the hex bolt or the insert may become damaged.
 - g. Repeat **Step 3** to drill the 5/16" hole through the pinch weld as needed.
 - h. Select the passenger side #3 Mounting Bracket. Attach the Bracket to the Insert and Clip Nut with (2) 8mm x 25mm Hex Bolts, (2) 8mm Lock Washers and (2) 8mm Flat Washers, **(Figure 21)**. Do not fully tighten hardware at this time.
 - i. Repeat **Steps a—h** to install the identical #4 and #5 Brackets, **(Figures 23, 24, 28, 29 and 33)**.
12. Select the long passenger side Running Board. Place the Running Board on top of the (5) Brackets. Locate the channels in the bottom of the Running Board. Select (5) 6mm Double Bolt Plates, **(Figure 10)**. Insert the Bolt Plates into the channels in the bottom of the Running Board closest to the Brackets, **(Figure 11)**. Attach the Running Board to the Brackets with (10) 6mm Flat Washers, (10) 6mm Lock Washers and (10) 6mm Hex Nuts, **(Figures 32 & 33)**. Do not tighten hardware at this time.
13. Level and adjust the Running Board forward or backward as desired to match driver side and fully tighten all hardware, **(Step 8)**.
14. Do periodic inspections to the installation to make sure that all hardware is secure and tight.

To protect your investment, wax this product after installing. Regular waxing is recommended to add a protective layer over the finish. Do not use any type of polish or wax that may contain abrasives that could damage the finish. Aluminum polish may be used to polish small scratches and scuffs on the finish. Mild soap may be used also to clean the Running Boards.

Driver/Left Side Installation Pictured

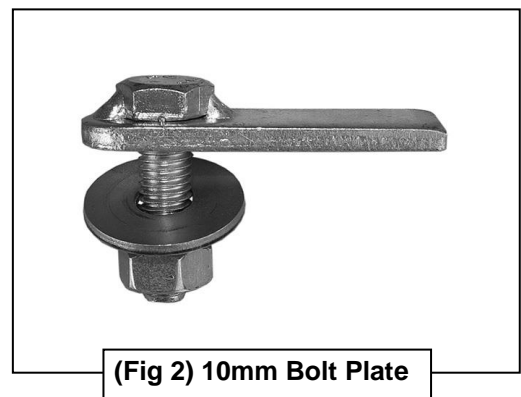
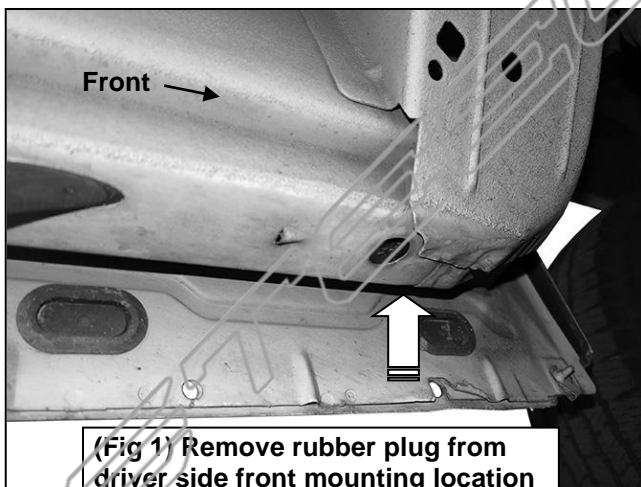

Driver/Left Side Installation Pictured

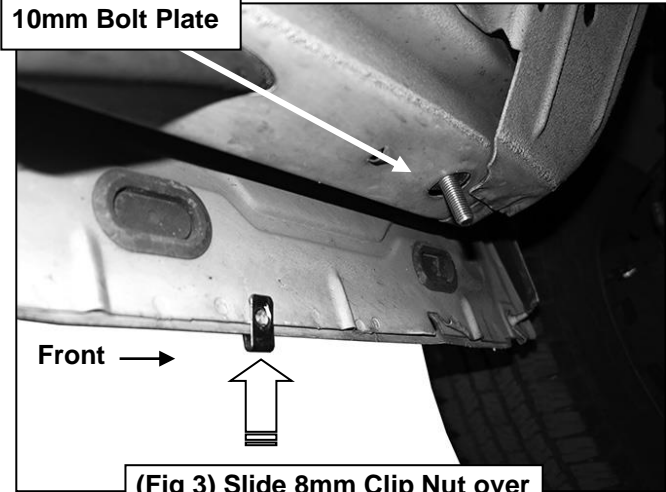

(Fig 3) Slide 8mm Clip Nut over factory hole in pinch weld

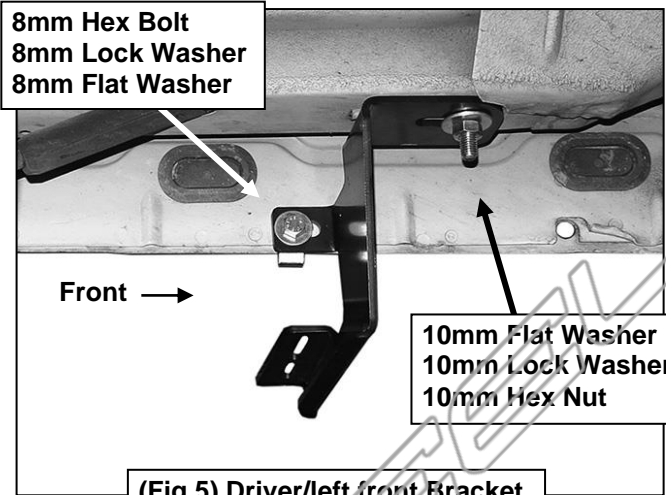

(Fig 5) Driver/left front Bracket

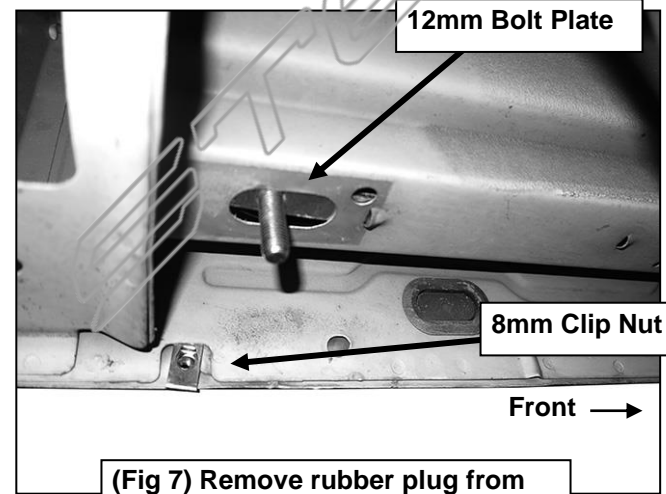

(Fig 7) Remove rubber plug from driver side rear mounting location

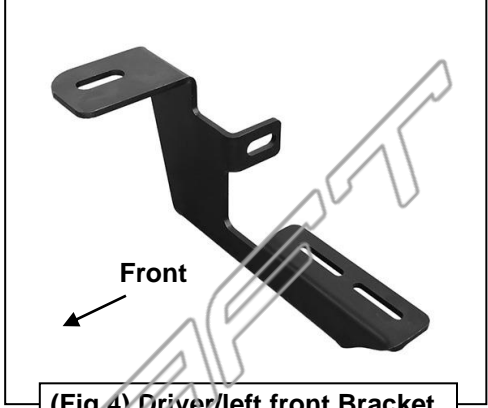

(Fig 4) Driver/left front Bracket

IMPORTANT: On some model/years, 5/16" holes will need to be drilled through the pinch weld to attach the tab on the Mounting Bracket to the pinch weld. Attach the Brackets to the Bolt Plates first, temporarily install the Running Board, and make sure Board is level then mark holes before drilling holes through pinch weld. Repeat for all Bracket installations

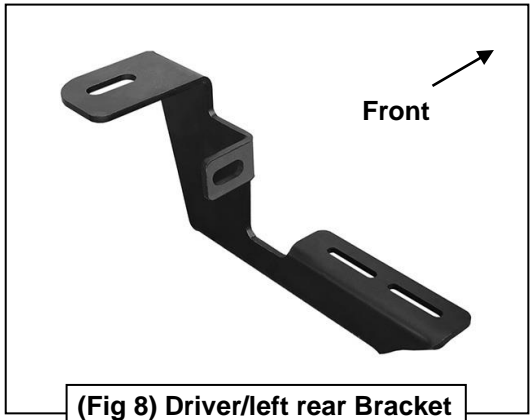
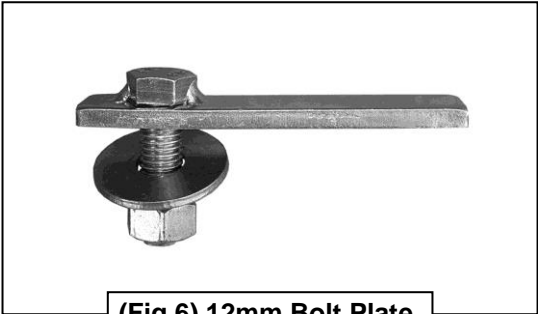

(Fig 8) Driver/left rear Bracket

Driver/Left side installation pictured

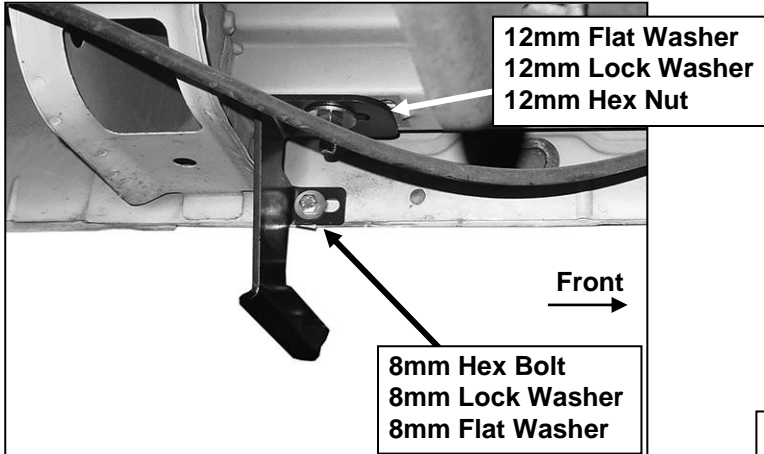

(Fig 9) Driver/left side rear Bracket installation

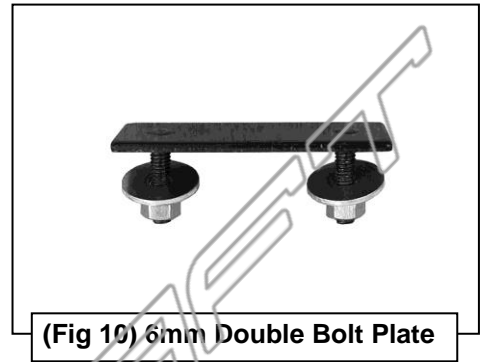

- (2) 6mm Flat Washers
- (2) 6mm Lock Washers
- (2) 6mm Hex Nuts

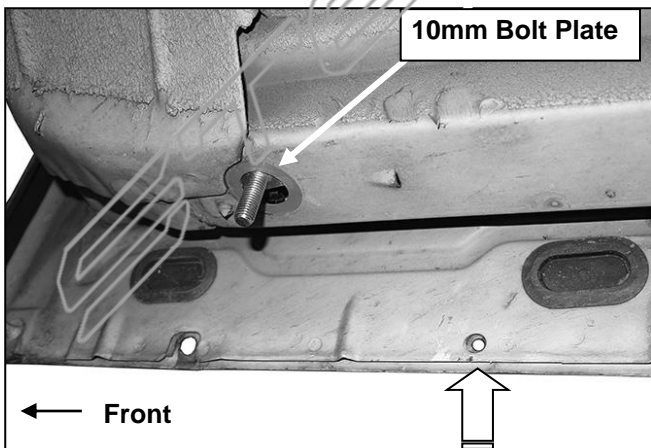
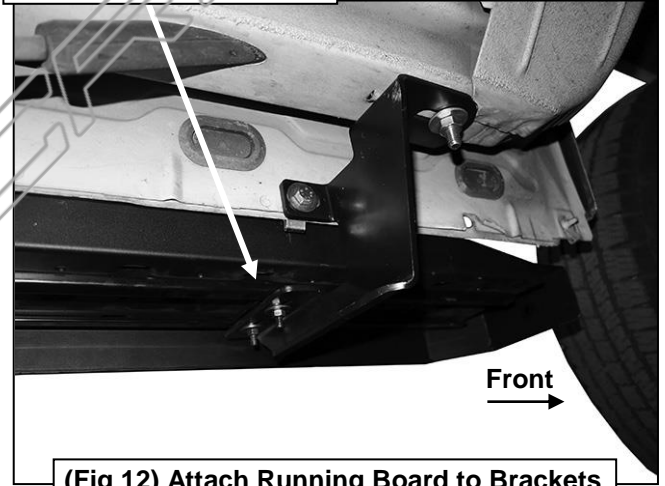
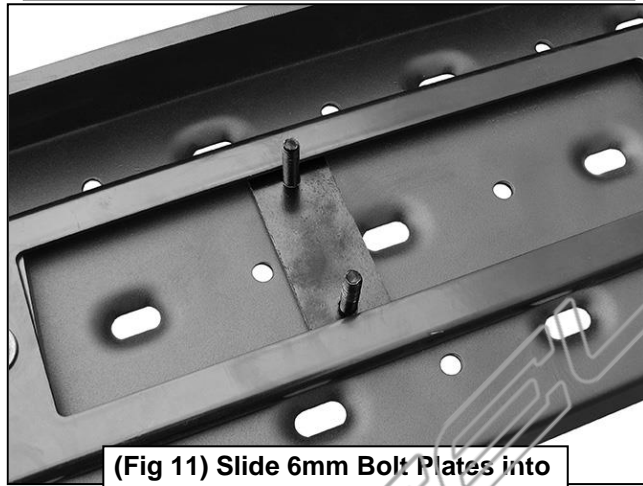

(Fig 13) Passenger/right front location pictured. Slide 8mm Clip Nut over factory hole in pinch weld

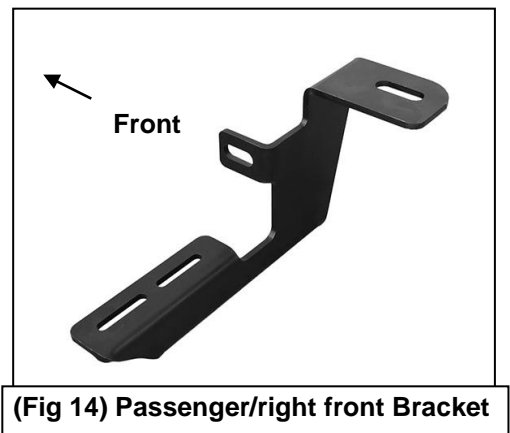

Passenger/right side installation pictured

10mm Flat Washer
10mm Lock Washer
10mm Hex Nut

8mm Hex Bolt
8mm Lock Washer
8mm Flat Washer



(Fig 15) Passenger/right front Bracket

12mm Bolt Plate

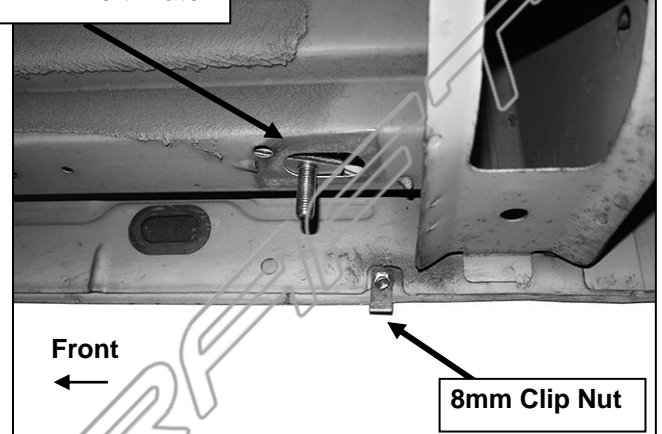

(Fig 16) passenger side #2 mounting location

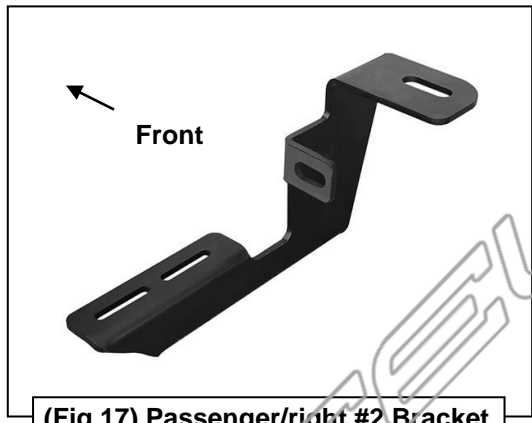

(Fig 17) Passenger/right #2 Bracket

8mm Hex Bolt
8mm Lock Washer
8mm Flat Washer

12mm Flat Washer
12mm Lock Washer
12mm Hex Nut

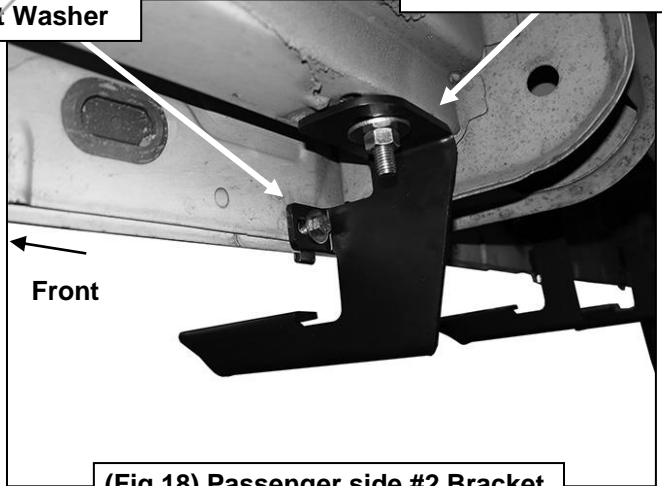

(Fig 18) Passenger side #2 Bracket

8mm Clip Nut

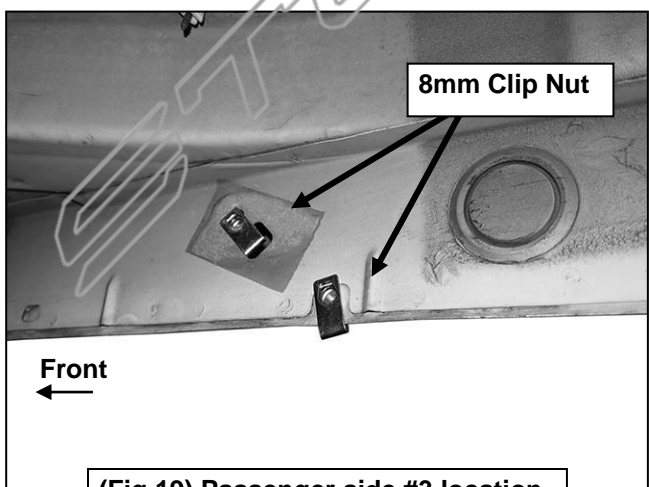

(Fig 19) Passenger side #3 location

IMPORTANT: On some model/years, 5/16" holes will need to be drilled through the pinch weld (see above) to attach the tab on the Mounting Bracket to the pinch weld. Attach the Brackets to the Bolt Plates first, temporarily install the Running Board, and make sure Board is level then mark holes before drilling holes through pinch weld. Repeat for all Bracket installations

Passenger/right side installation pictured

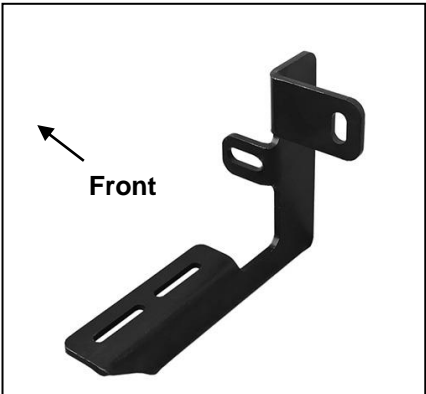

(Fig 20) Passenger side #3 Bracket

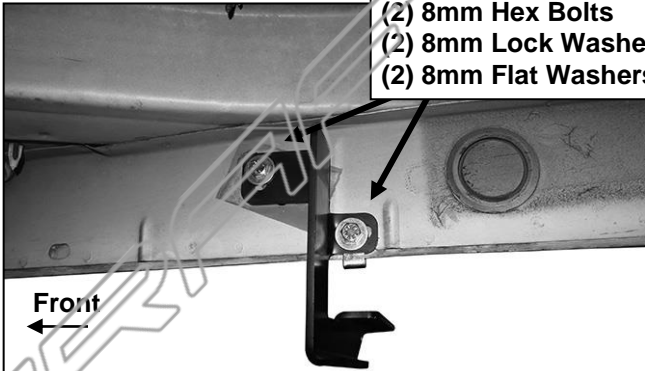

(Fig 21) Passenger side #3 Mounting Bracket

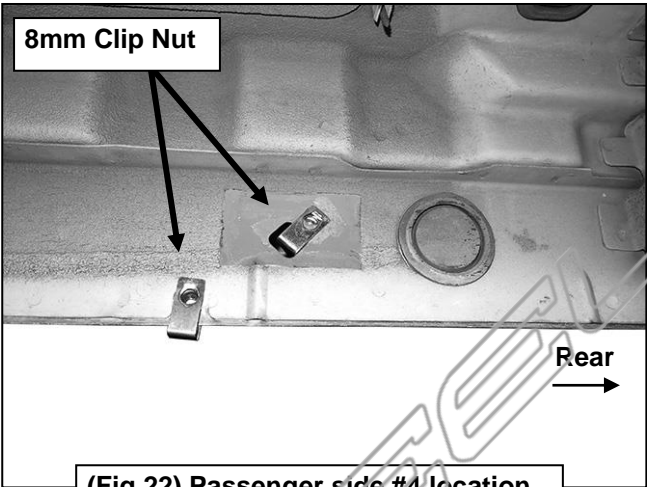

(Fig 22) Passenger side #4 location



(Fig 23) Passenger side #4 Bracket

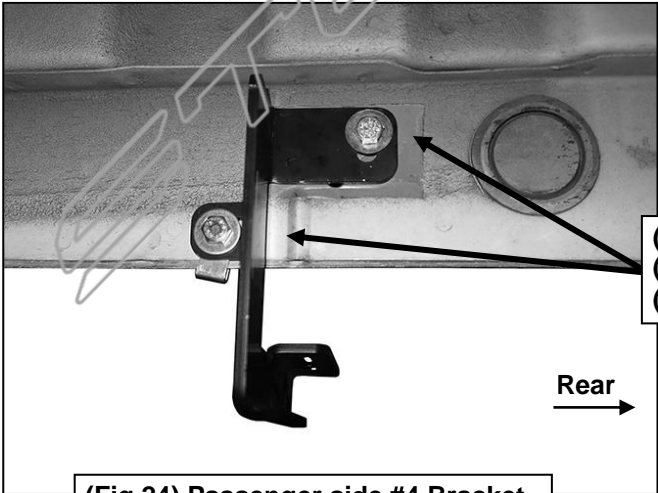

(Fig 24) Passenger side #4 Bracket

Passenger/right side installation pictured

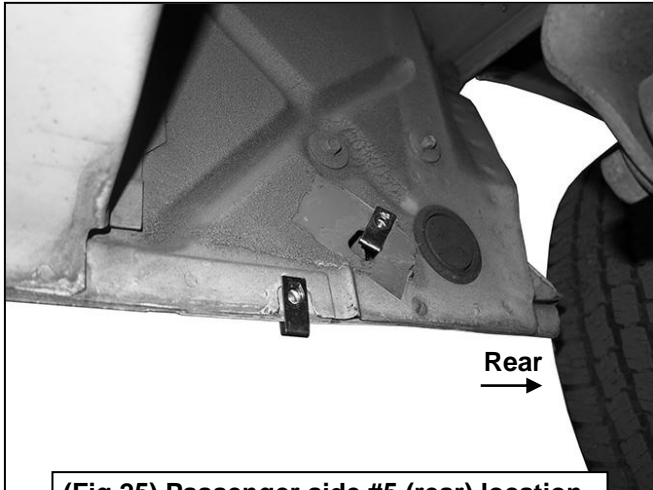

(Fig 25) Passenger side #5 (rear) location

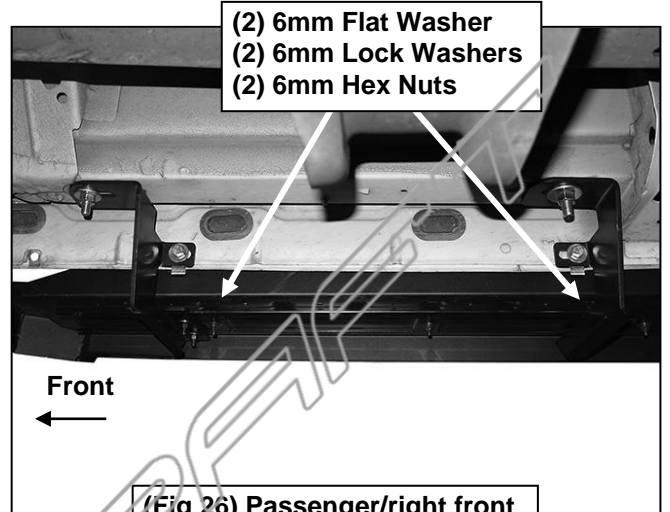

(Fig 26) Passenger/right front and #2 Bracket installation

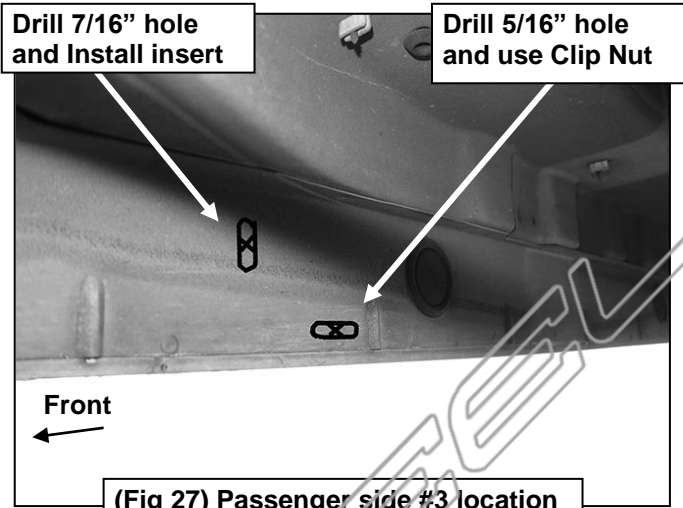

(Fig 27) Passenger side #3 location

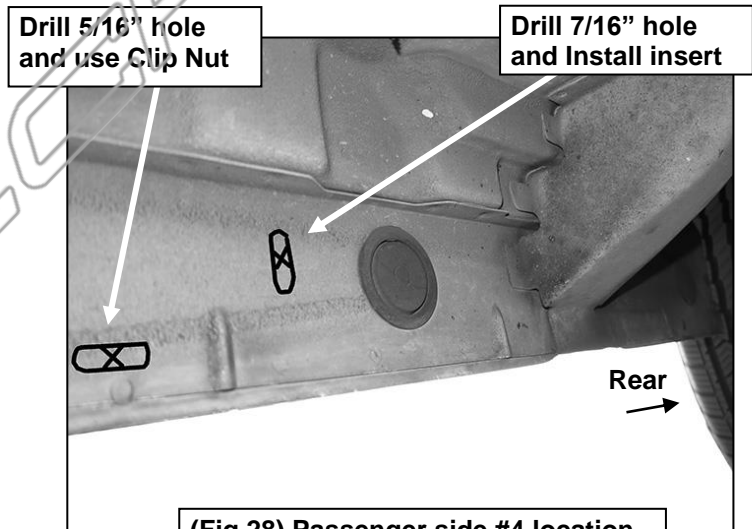

(Fig 28) Passenger side #4 location

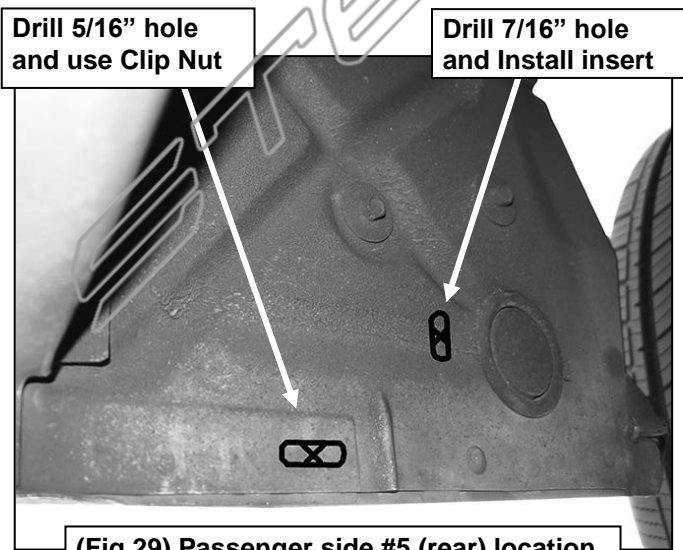

(Fig 29) Passenger side #5 (rear) location

IMPORTANT: On some model/years, 8mm Threaded Inserts will need to be installed in locations indicated by arrows, (Fig 27-29). Level Running Board. Hold Bracket up in position against side of body panel. Mark location of slots onto sheet metal. Drill (3) 7/16" holes as required for passenger side #3, #4 and #5 (rear) Brackets only. Assemble Insert Tool and install Inserts as described in Steps 11a-i, (Fig 30-31).

Passenger/right side installation pictured



(Fig 30) Assemble Insert Tool as pictured. Turn wrench clockwise to pull/expand insert in hole

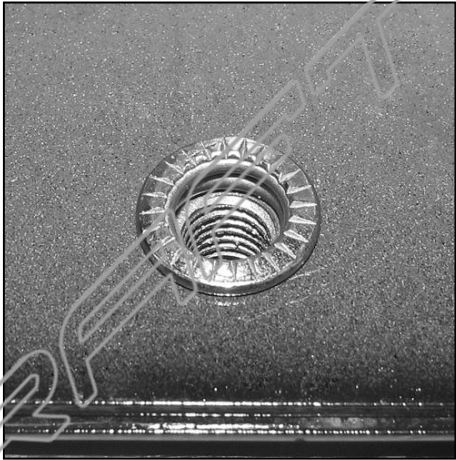

(Fig 31) Example fully installed Insert



- (2) 6mm Flat Washer
- (2) 6mm Lock Washers
- (2) 6mm Hex Nuts

Rear
→

(Fig 32) Passenger/right #3 Bracket installation

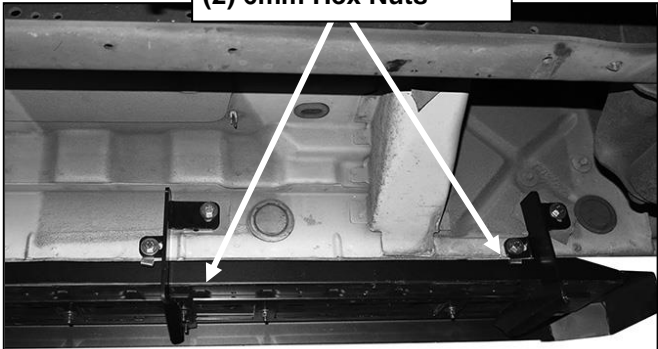

- (2) 6mm Flat Washer
- (2) 6mm Lock Washers
- (2) 6mm Hex Nuts

Rear
→

(Fig 33) Passenger/right #4 and #5, (rear), Bracket installation pictured. NOTE #4 and #5 Brackets are



Complete Installation-Passenger Side