

**STX600 RUNNING BOARDS  
2012-17 NISSAN NV 1500-3500 VAN (FULL SIZE)**

**PARTS LIST:**

1	Driver/left Running Board	13	10mm Nylon Lock Nuts
1	Passenger/right Running Board	6	10mm Plastic Retainers
1	Driver/left Front Mounting Bracket	2	8-1.25mm x 30mm Hex Bolts
1	Driver/left Center Mounting Bracket	4	8mm x 24mm OD x 2mm Flat Washers
1	Driver/left Rear Mounting Bracket	2	8mm Lock Washers
1	Passenger/right Front Mounting Bracket	2	8-1.25mm Hex Nuts
1	Passenger/right #2 Mounting Bracket	14	6mm x 22mm OD x 2mm Flat Washers
1	Passenger/right #3 Mounting Bracket	14	6mm Lock Washers
1	Passenger/right Rear Mounting Bracket	14	6mm Hex Nuts
13	10-1.5mm x 35mm Bolt Plates	7	6mm Double Bolt Plates
13	10mm x 27mm OD x 3mm Flat Washers		

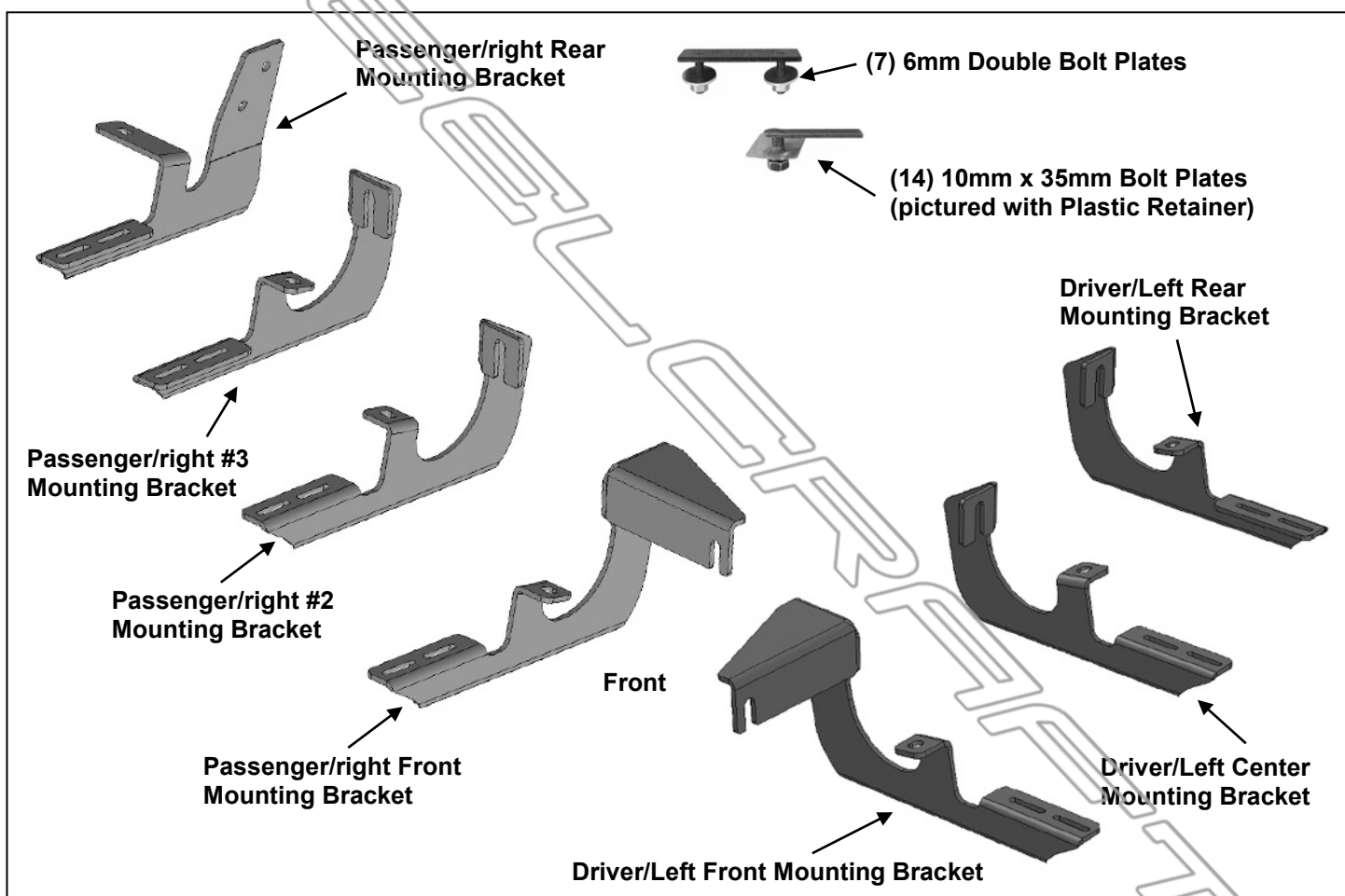

**PROCEDURE:**

**REMOVE CONTENTS FROM BOX. VERIFY ALL PARTS ARE PRESENT. READ INSTRUCTIONS CAREFULLY BEFORE STARTING INSTALLATION. ASSISTANCE IS RECOMMENDED.**

1. Start the installation under the passenger side of the vehicle. Locate the factory hole closest to the front wheel opening along the bottom of the body, **(Figures 1 & 3)**. **NOTE:** Holes will be covered with plugs or tape, remove as necessary. Select (1) 10mm Bolt Plate, **(Figure 2)**. Insert the Bolt Plate into the hole.
2. Next, locate the first factory hole along the inner body panel, **(Figures 1 & 3)**. Remove excess undercoating from all mounting locations so that Brackets will install flat against body panel. Select (1) 10mm Bolt Plate and (1) 10mm Plastic Retainer, **(Figure 2)**. Thread the Retainer part way onto the Bolt

**STX600 RUNNING BOARDS**  
**2012-17 NISSAN NV 1500-3500 VAN (FULL SIZE)**

Plate. Insert the Bolt Plate into the hole and tighten the Retainer against the side of the body panel, **(Figure 3)**. **IMPORTANT:** The Plastic Retainer is designed to prevent the Bolt Plate from falling into the body panel and to aid in Bracket installation. Retainers are not required for the Bolt Plates installed along the bottom of the outer body panel (outside of pinch weld).

3. Select the passenger side front Mounting Bracket, **(Figure 4)**. Line up the Bracket with the (2) Bolt Plates. Attach the Bracket to the Bolt Plates with (2) 10mm Flat Washers and (2) 10mm Nylon Lock Nuts, **(Figure 5)**. Do not fully tighten hardware at this time.
4. Move to the next mounting location below the center of the passenger side front door, **(Figures 1 & 6)**. Locate the hole in the bottom of the body panel and the hole in the inner side of the body panel. Repeat **Steps 1—3** to install the passenger side #2 Bracket, **(Figures 6—8)**.
5. Continue along the body to the #3 mounting location beneath the front of the sliding door, **(Figures 1 & 9)**. Repeat **Steps 1—3** to install the passenger side #3 Mounting Bracket, **(Figures 9—11)**.
6. Next, locate the last mounting hole along the bottom of the body, **(Figures 1 & 12)**. Insert (1) Bolt Plate as previously described. Select the passenger/right rear Bracket, **(Figure 13)**. Attach the Bracket to the Bolt Plate with (1) 10mm Flat Washer and (1) 10mm Nylon Lock Nut, **(Figure 14)**. Line up the mounting plate on the Bracket with the front facing side of the inner body brace. Do not fully tighten hardware.
7. Select the long passenger side Running Board. Place the Running Board on top of the (4) Brackets. Select (4) 6mm Double Bolt Plates, **(Figure 15)**. Locate the channels in the bottom of the Running Board, **(Figure 16)**. Insert the Bolt Plates into the channels in the bottom of the Running Board closest to the Brackets. Lift the Running Board up and guide the studs down through the Brackets.
8. Attach the Running Board to the Brackets with (8) 6mm Flat Washers, (8) 6mm Lock Washers and (8) 6mm Hex Nuts, **(Figure 17)**. **NOTE:** The Running Board is designed to fit close to the vehicle. It may be necessary to loosen the Bracket hardware and tilt the Brackets downward to insert the Running Board between the Brackets and the body. Do not tighten hardware at this time.
9. Level and adjust the Running Board and fully tighten all Bracket to Body hardware only. **NOTE:** Line up the front end of the Board with the front of the front door.
10. Return to the passenger side rear Bracket. With the Running Board level, mark the location of the (2) mounting holes on the Bracket onto the inner body brace. **(Figure 18)**. Temporarily remove the Bracket only. Drill (2) 5/16" or 3/8" max holes through the marked locations, **(Figure 19)**. Reinstall the Bracket. Attach Bracket to inner body brace with the included (2) 8mm x 30mm Hex Bolts, (4) 8mm Flat Washers, (2) 8mm Lock Washers and (2) 8mm Hex Nuts, **(Figure 20)**. Check Running Board for level, adjust as necessary and fully tighten all hardware.
11. Move to the driver side of the vehicle. Repeat **Steps 1—3**, **(Figures 1 & 2)**, to install the driver side front Bracket, **(Figures 21—24)**.
12. Move to the center location. Repeat **Steps 1—4** to install the center Bracket, **(Figures 21, 22, 25 & 27)**.
13. Continue to the driver side rear location at the back of the front door. Repeat **Steps 1—6** to install the driver side rear Bracket, **(Figures 21, 26 & 27)**.
14. Select the driver side Running Board. Place the Running Board on top of the (3) Brackets. Select (3) 6mm Double Bolt Plates. Repeat **Steps 7 & 8** to attach Running Board to the (3) Brackets, **(Figure 28)**.
15. Level and adjust the Running Board to match passenger side and fully tighten all hardware.
16. Do periodic inspections to the installation to make sure that all hardware is secure and tight.

**To protect your investment**, wax this product after installing. Regular waxing is recommended to add a protective layer over the finish. Do not use any type of polish or wax that may contain abrasives that could damage the finish. Mild soap may be used also to clean the Running Board.

STX600 RUNNING BOARDS  
2012-17 NISSAN NV 1500-3500 VAN (FULL SIZE)  
Passenger/right Side Installation Pictured

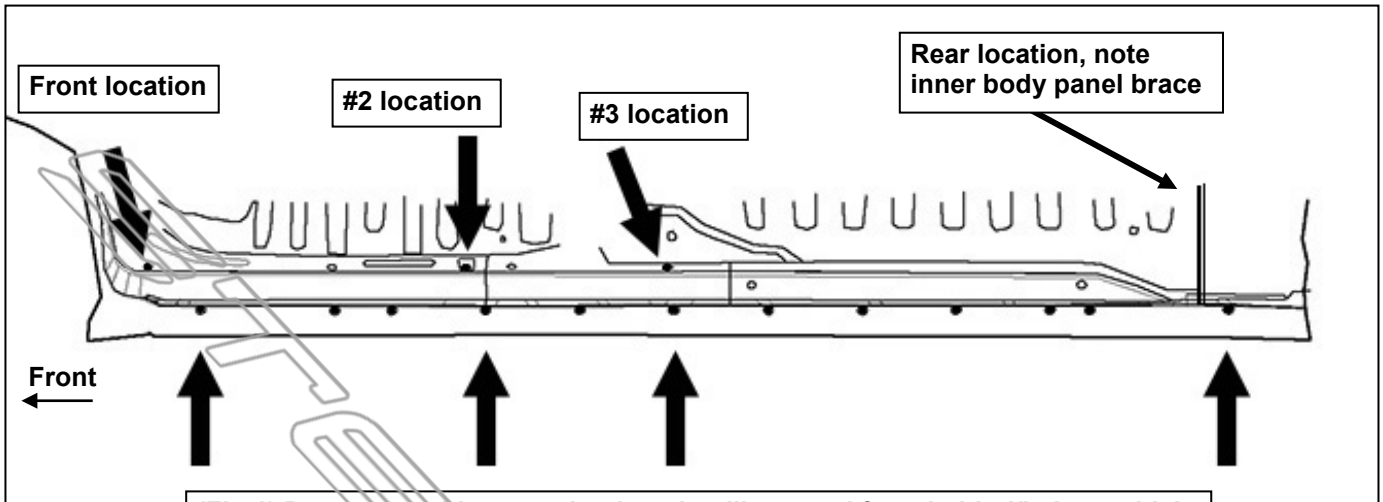

(Fig 1) Passenger side mounting location illustrated from behind/below vehicle

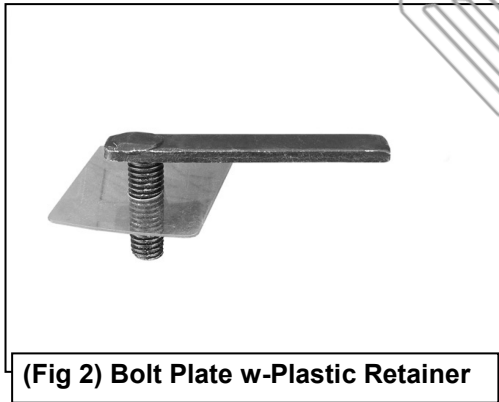

(Fig 2) Bolt Plate w-Plastic Retainer

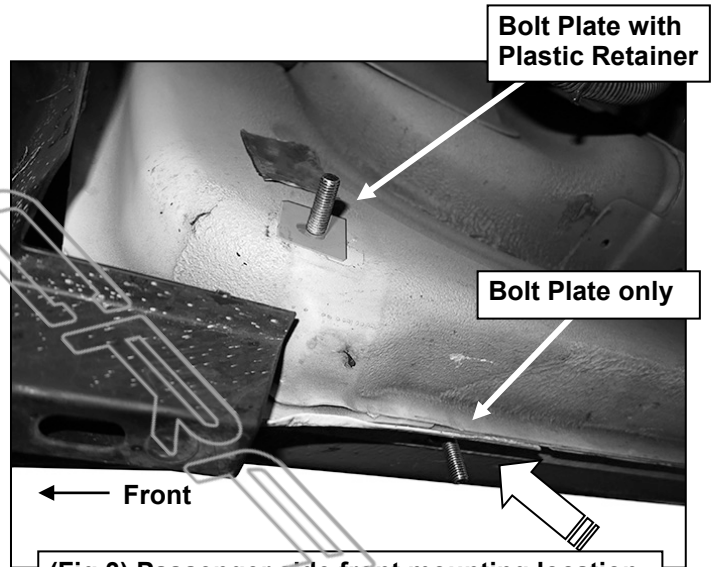

(Fig 3) Passenger side front mounting location

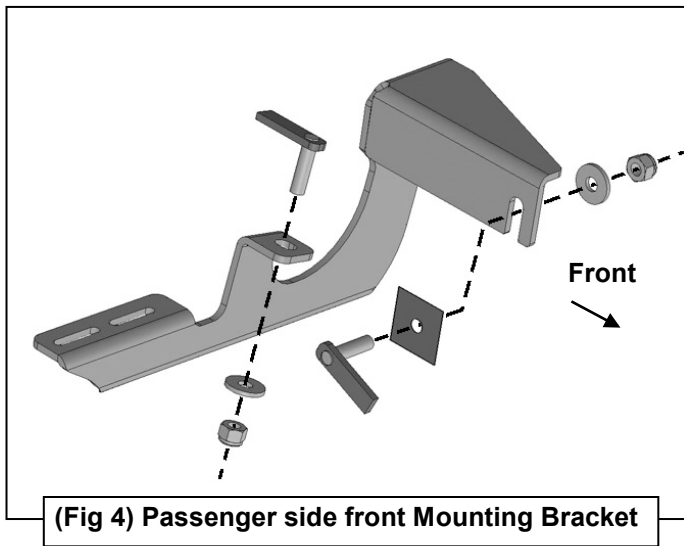

(Fig 4) Passenger side front Mounting Bracket

**STX600 RUNNING BOARDS**  
**2012-17 NISSAN NV 1500-3500 VAN (FULL SIZE)**

**Passenger/right Side Installation Pictured**

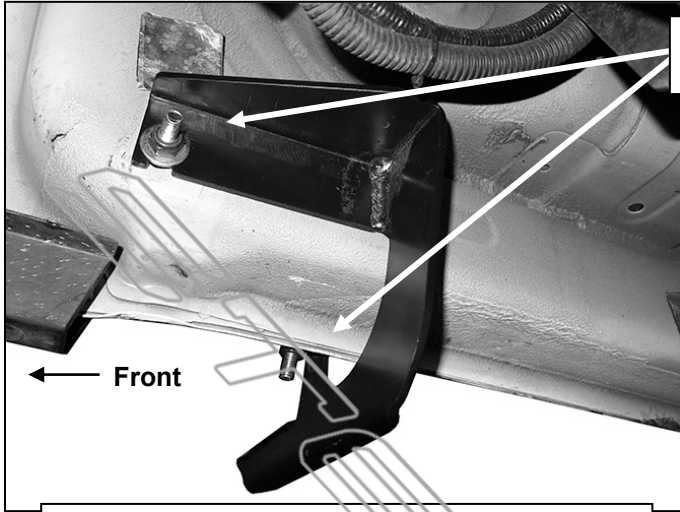

10mm Flat Washer  
 10mm Nylon Lock Nut

**(Fig 5) Attach Mounting Bracket to Bolt Plates**

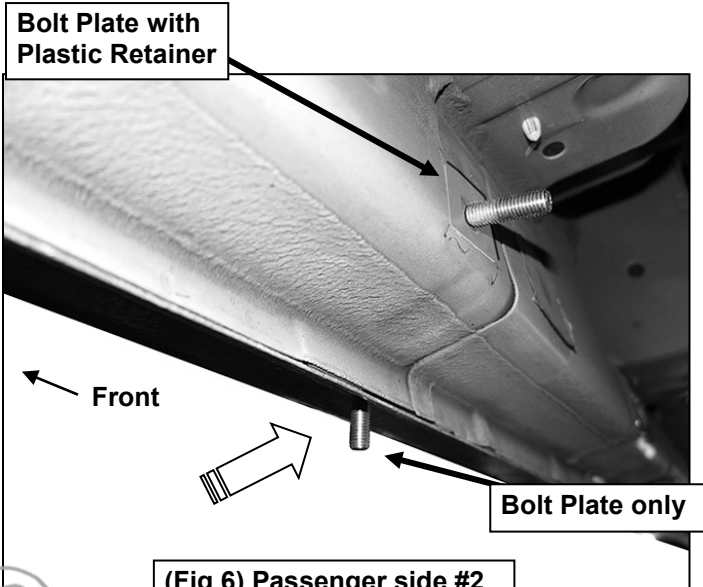

Bolt Plate with  
 Plastic Retainer

Bolt Plate only

**(Fig 6) Passenger side #2  
 Bracket mounting location**

10mm Bolt Plate  
 10mm Flat Washer  
 10mm Nylon Lock Nut

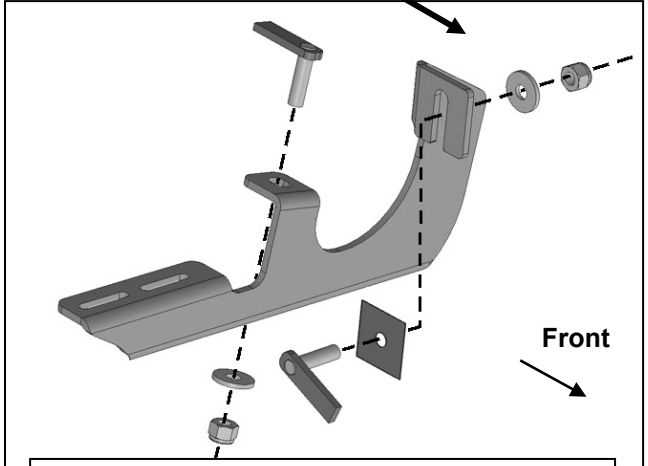

**(Fig 7) Passenger side #2 Mounting Bracket**

10mm Flat Washer  
 10mm Nylon Lock Nut

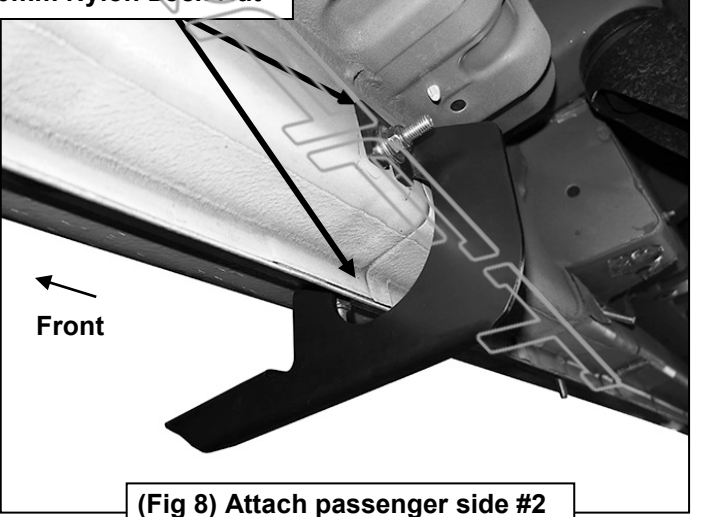

**(Fig 8) Attach passenger side #2  
 Mounting Bracket to Bolt Plates**

Passenger/right Side Installation Pictured

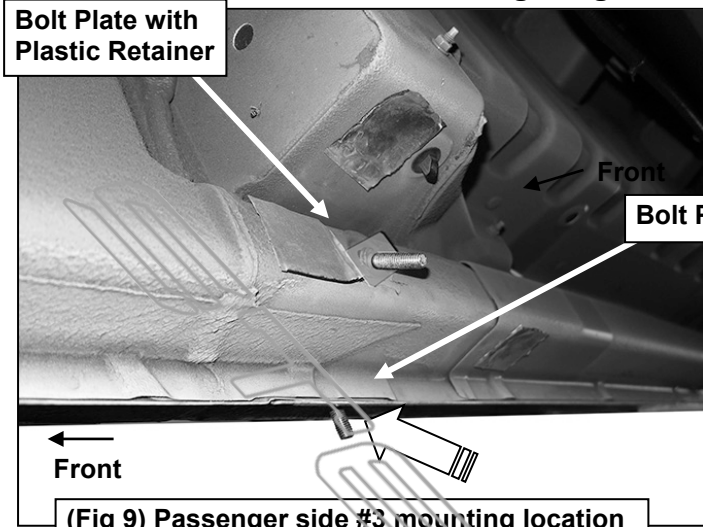

(Fig 9) Passenger side #3 mounting location

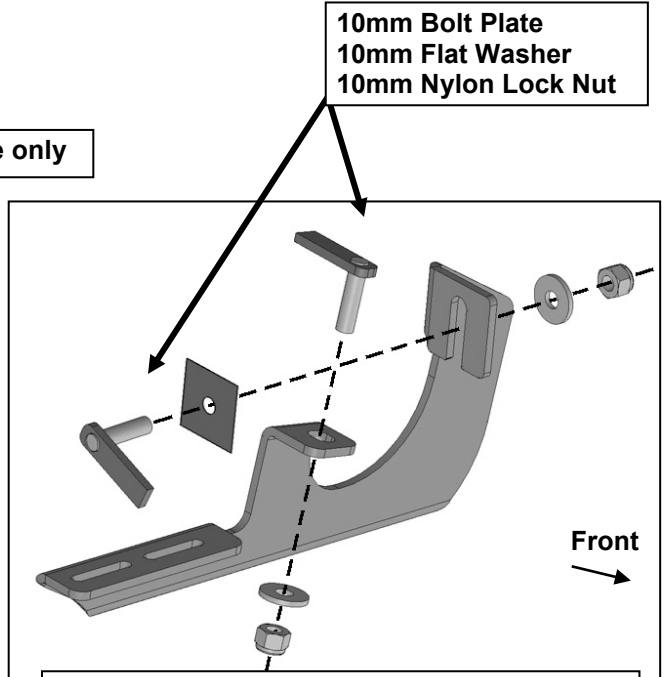

(Fig 10) Passenger side #3 Mounting Bracket

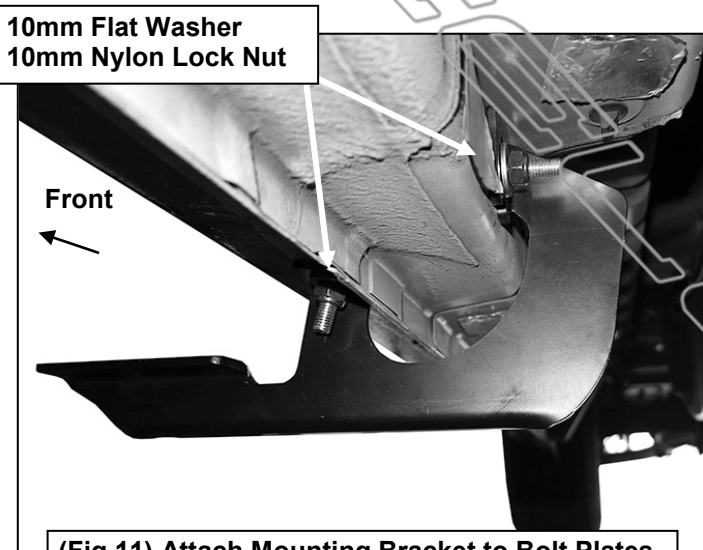

(Fig 11) Attach Mounting Bracket to Bolt Plates

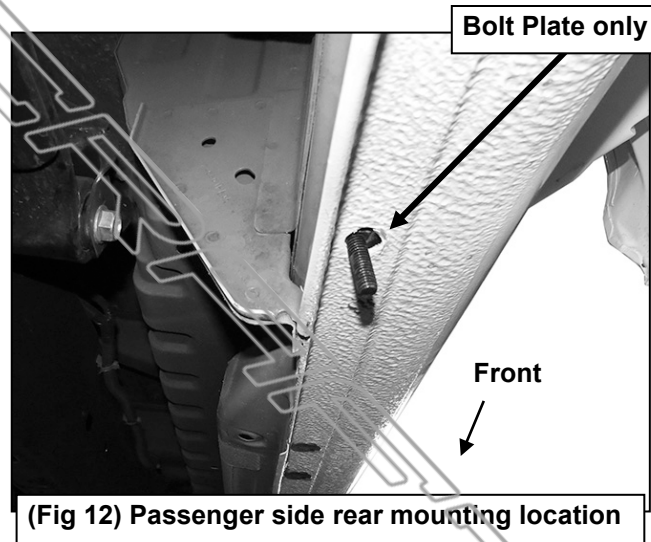

(Fig 12) Passenger side rear mounting location

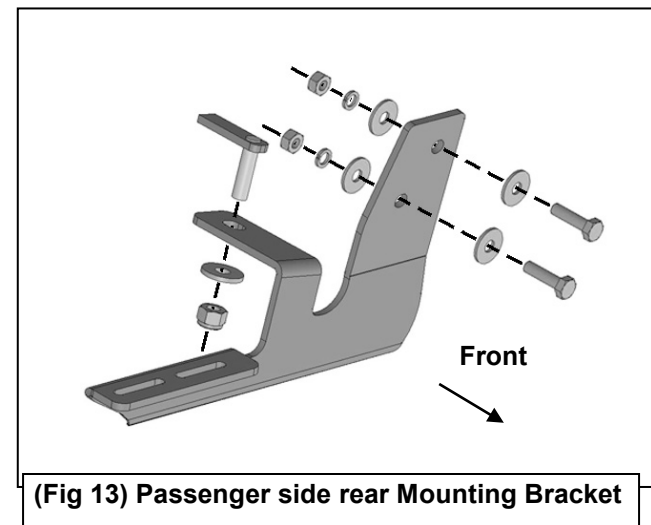

(Fig 13) Passenger side rear Mounting Bracket

Passenger/right Side Installation Pictured

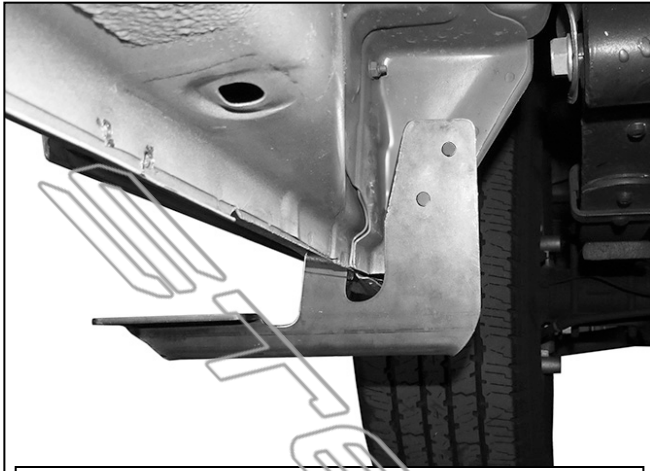

(Fig 14) Passenger side rear mounting Bracket



(Fig 15) 6mm Double Bolt Plate

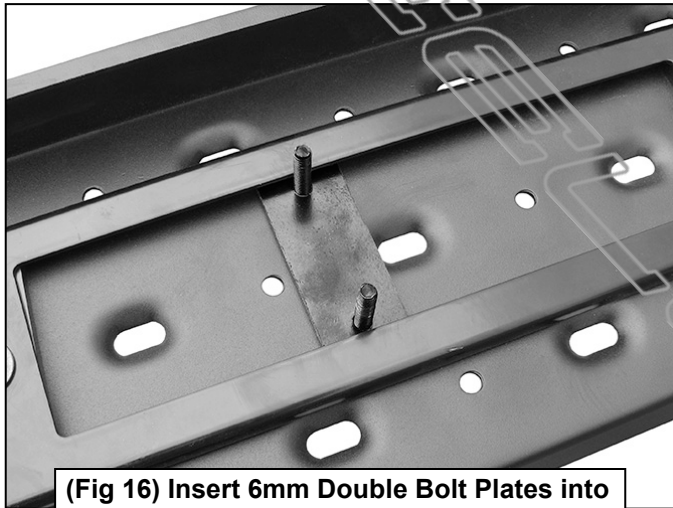

(Fig 16) Insert 6mm Double Bolt Plates into tracks on the bottom of the Running Board

- (2) 6mm Flat Washers
- (2) 6mm Lock Washers
- (2) 6mm Hex Nuts



(Fig 17) Passenger front Bracket with Running Board

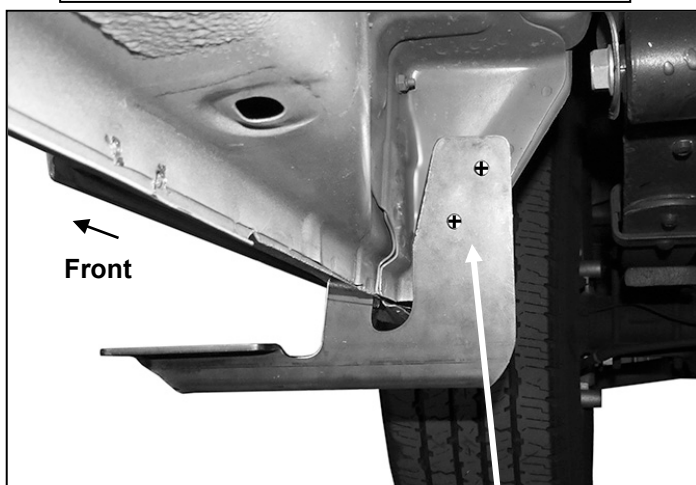

(Fig 18) Mark (2) hole locations, temporarily remove Running Board and passenger/right rear Bracket

**STX600 RUNNING BOARDS  
2012-17 NISSAN NV 1500-3500 VAN (FULL SIZE)**

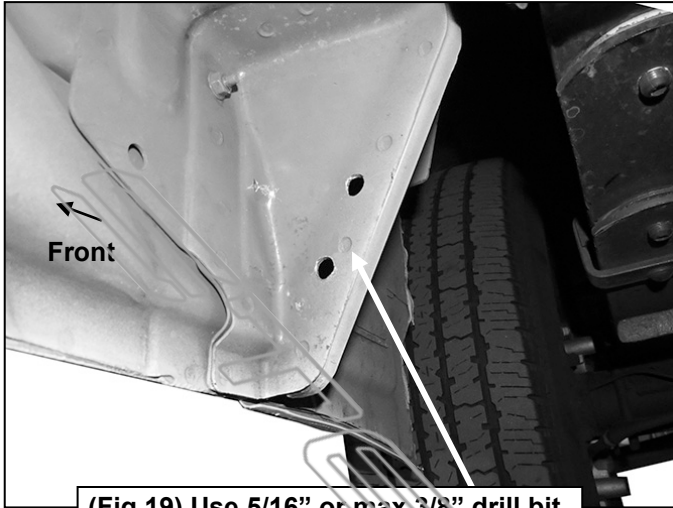

**(Fig 19) Use 5/16" or max 3/8" drill bit**

- (2) 8mm x 30mm Hex Bolts**
- (4) 8mm Flat Washers**
- (2) 8mm Lock Washers**
- (2) 8mm Hex Nuts**



**(Fig 20) Passenger/right rear complete installation**

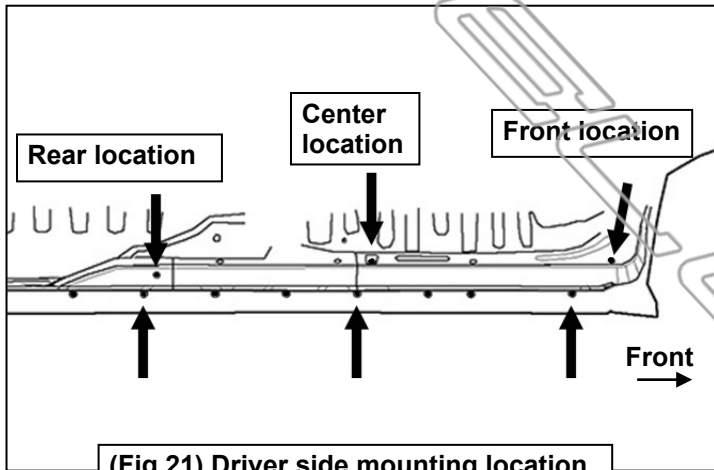

**(Fig 21) Driver side mounting location illustrated from behind/below vehicle**

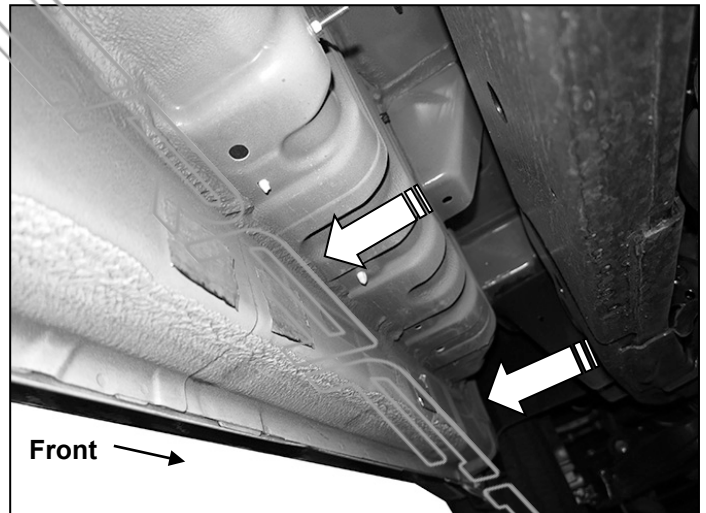

**(Fig 22) Driver side front and center mounting locations**

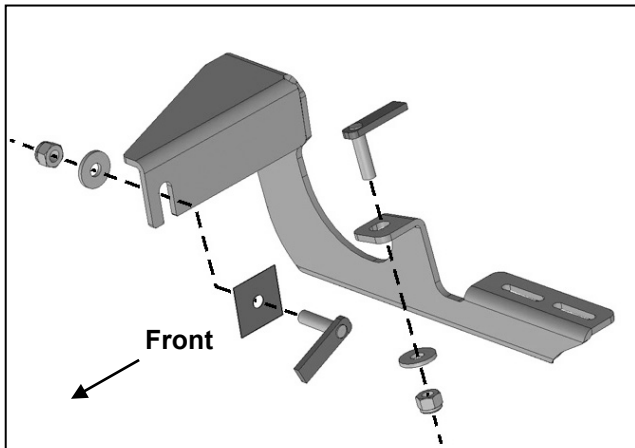

**(Fig 23) Driver side front Mounting Bracket**



Driver/left Side Installation Pictured

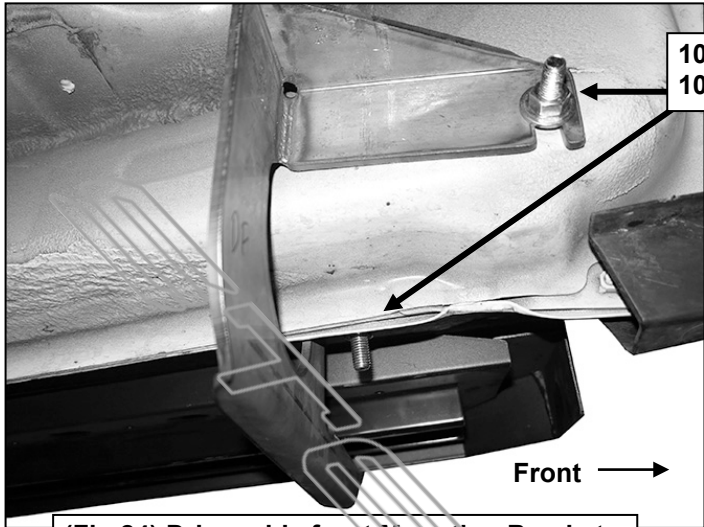

(Fig 24) Driver side front Mounting Bracket

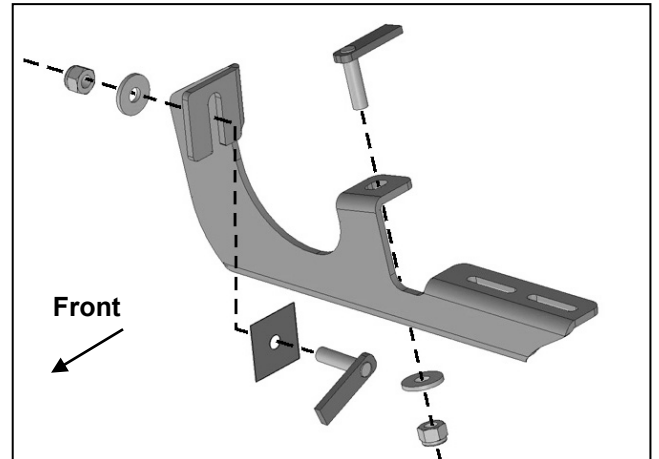

(Fig 25) Driver side center Mounting Bracket

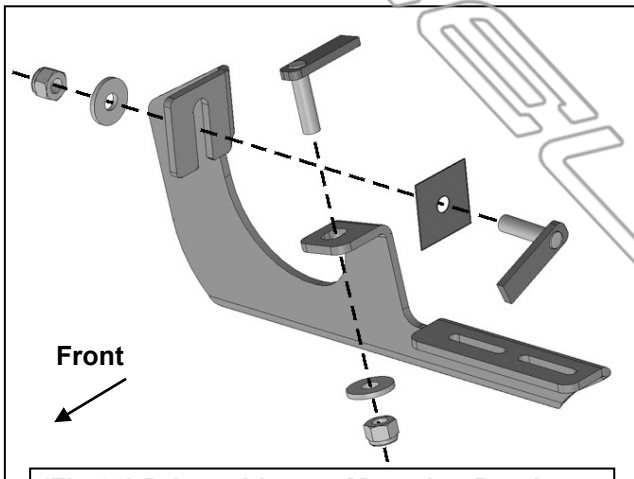

(Fig 26) Driver side rear Mounting Bracket

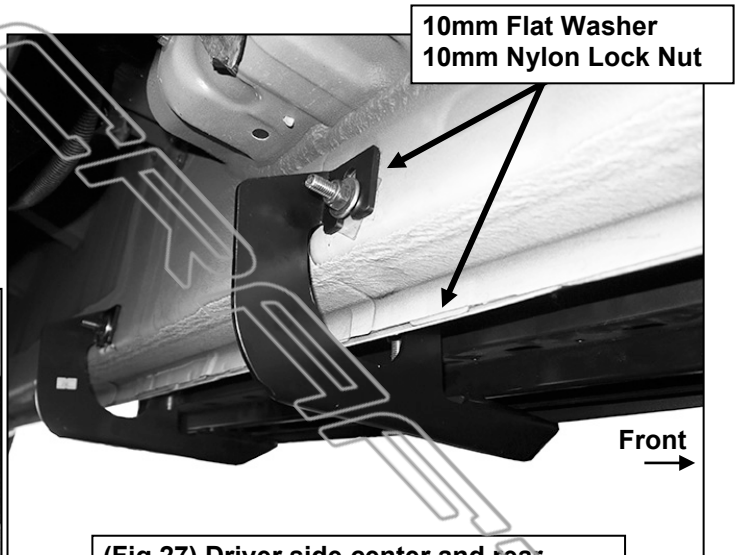

(Fig 27) Driver side center and rear Mounting Brackets completely installed



(Fig 28) Driver side complete installation