

# **INSTALLATION INSTRUCTIONS**

**ELEVATION FRONT BUMPER  
2019 CHEVY SILVERADO 1500  
EXCLUDES 2019 SILVERADO 1500 "LD" CLASSIC**

**ELEVATION FRONT BUMPER  
2019 CHEVY SILVERADO 1500  
EXCLUDES 2019 SILVERADO 1500 "LD" CLASSIC**

**PARTS LIST:**

1	Elevation Front Bumper Assembly	8	12-1.75mm Bolt Plates
1	Driver/left Mounting Bracket Assembly	2	12-1.75mm x 120mm Hex Bolts
1	Passenger/right Mounting Bracket Assembly	10	12-1.75mm x 50mm Hex Bolts
2	Left Facing Support Brackets	32	12mm x 32mm x 3mm Flat Washers
2	Right Facing Support Brackets	20	12mm Nylon Lock Nuts
2	Plastic Plugs for License Plate	6	6mm x 20mm Hex Bolts
4	15.5mm x 25mm x 2mm Foam Seals	12	6mm x 18mm x 1.6 Flat Washers
4	20mm x 2mm Foam Washers	6	6mm Nylon Lock Nut
4	Sensor Retaining Clips	8	4mm x 10mm Button Head Screws
4	Rubber Sensor plugs	1	Wrench
3	Sensor Wire Harnesses	1	Sensor Cover Kit

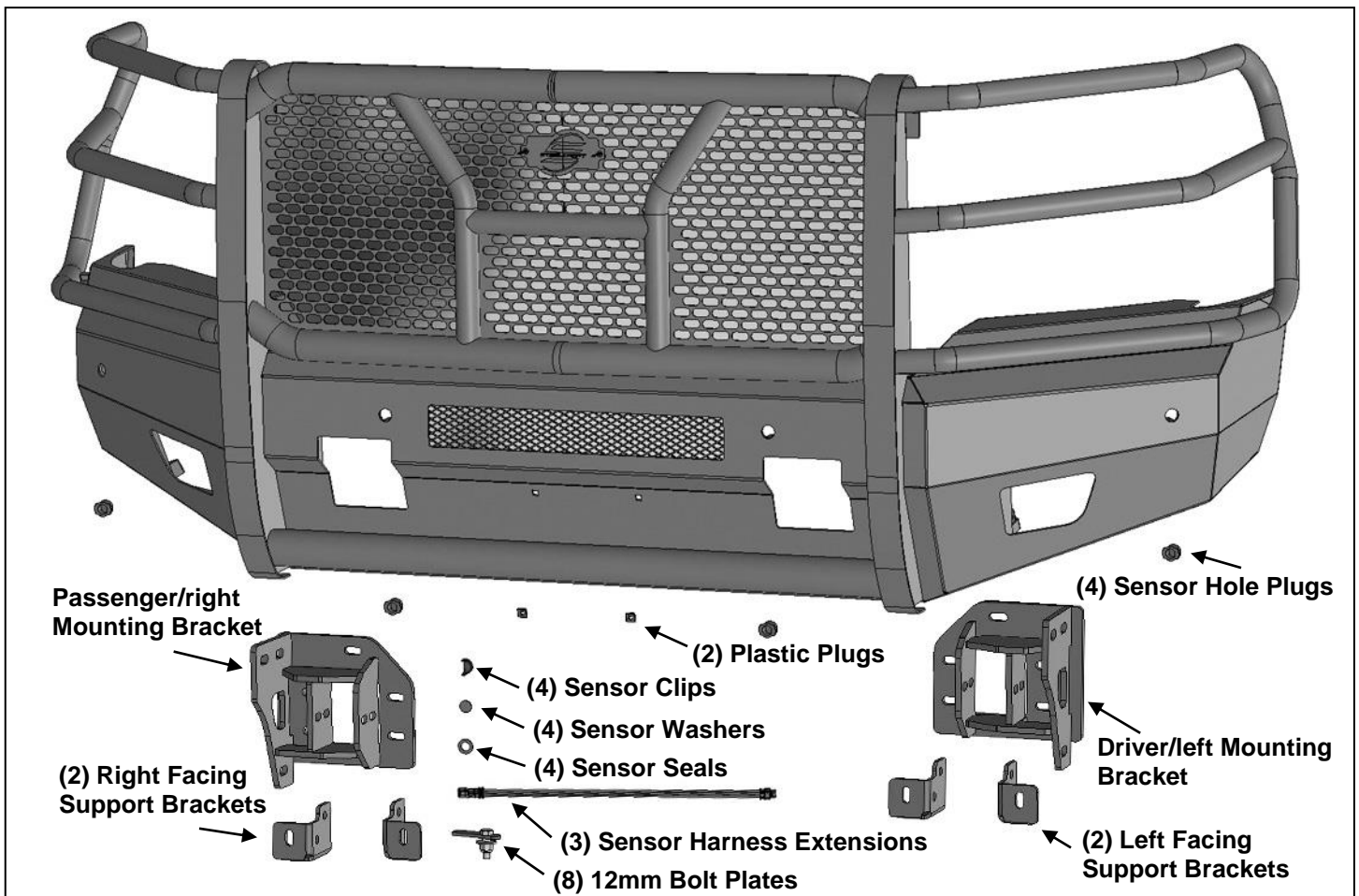

**PROCEDURE:**

**REMOVE CONTENTS FROM BOX. VERIFY ALL PARTS ARE PRESENT. READ INSTRUCTIONS CAREFULLY BEFORE STARTING INSTALLATION. ASSISTANCE IS HIGHLY RECOMMENDED TO AVOID POSSIBLE INJURY OR DAMAGE TO THE VEHICLE.**

1. Open the hood and remove the plastic cover from the top of the grille and radiator, **(Figure 1)**. Models with grille mounted camera, unplug camera if equipped. Next, remove the screws attaching the grille to the radiator core support. Once all hardware has been removed, firmly pull the grille straight out from the vehicle to release the grille from the clips, **(Figure 2)**. Place grille on a clean, soft surface.
2. Remove the license plate and bracket. On models with factory fog lights and/or bumper sensors, unplug the wiring harness leading to the bumper. **NOTE:** Wiring harness connector is located up and behind the passenger/right side of the bumper. Move harness away from bumper.

**ELEVATION FRONT BUMPER  
2019 CHEVY SILVERADO 1500  
EXCLUDES 2019 SILVERADO 1500 "LD" CLASSIC**

3. From behind the driver/left side of the bumper, remove the outer bumper support connected to the side of the frame and the outer end of the bumper, **(Figure 3)**.
4. Locate and remove the hex bolts attaching the bottom of the bumper to the bumper bracket attached to the end of the frame.
5. Repeat **Steps 3 & 4** to remove the passenger/right bumper support and lower bumper hardware.
6. Move back to the top of the bumper. Pull back the end of the rubber cover between the bumper and the bottom of the radiator to expose the bolts attaching the top of the bumper bracket to the frame bracket, **(Figure 4)**.
7. Place blocks or jack stands under the front bumper to support it during mounting bolt removal. Once the bumper has been safely supported, remove the bumper bolts attaching the bumper assembly to the top of the bumper bracket, **(Figure 4)**. **WARNING!** Assistance is required to hold the bumper in place during bolt removal to prevent the bumper from falling. Carefully slide the bumper assembly with brackets off of the ends of the frame.
8. Remove both bumper brackets and tow hooks, (if equipped), from the end of the frame, **(Figure 5)**.
9. Once bumper has been removed, reinstall the plastic grille, camera if equipped and cover removed in **Step 1**, **(Figure 6)**.
10. Select (1) Left Facing and (1) Right Facing Support Bracket, **(Figure 7)**. Starting on the driver/left side, attach the Right Facing Support Bracket to the inner facing side of the frame with (2) 12mm Bolt Plates, (2) 12mm Flat Washers and (2) 12mm Nylon Lock Nuts, **(Figures 7 & 8)**. Next, attach (1) Left Facing Support Bracket to the outer facing side of the frame with (2) 12mm Bolt Plates, (2) 12mm Flat Washers and (2) 12mm Nylon Lock Nuts, **(Figures 7 & 8)**. Do not tighten hardware at this time.
11. Select the driver/left Frame Mounting Bracket, **(Figure 9)**. Reuse the (3) factory bumper bolts to attach the top mounting holes on the Mounting Bracket to the threaded bumper mount, **(Figures 9 & 10)**. Attach the (2) lower holes in the Mounting Bracket to the (2) Support Brackets with (2) 12mm x 50mm Hex Bolts, (4) 12mm Flat Washers and (2) 12mm Nylon Lock Nuts, **(Figures 9—11)**. Snug but do not fully tighten hardware at this time.
12. Select (1) tow hook if equipped. Reuse the (1) short factory hex bolt to attach the rear mounting hole in the tow hook to the Frame Bracket, **(Figure 10)**. Use the included longer (1) 12mm x 120mm Hex Bolt, (2) 12mm Flat Washers and (1) 12mm Nylon Lock Nut to attach the front of the tow hook to the Frame Bracket. Fully tighten tow hook hardware only at this time.
13. Repeat **Steps 10—12** to install the passenger/right Support Brackets, Frame Bracket and tow hook if equipped, **(Figure 11)**.
14. Carefully unwrap the Bumper assembly. Determine if accessory light, (not included), will be installed at this time. **IMPORTANT:** It may be easier to install lights and sensors before installing Bumper.

**Inner center LED bar style light installation (light not included).**

- a. Attach the light to the mounting tabs on the back of the Bumper with the hardware included with the light.
15. Determine if the vehicle is equipped with front bumper sensors. **NOTE:** Sensors must be installed in Bumper before installing Bumper Assembly.

**Models without bumper sensors:**

- a. Select the included (4) Rubber Plugs, **(Figure 12)**.
- b. From behind bumper, push plugs into sensor mounting holes. Use the included 4mm Screws to lock the Plug in the sensor mount (optional).

**Models with bumper mounted sensors:**

- a. Remove the sensors and wiring harness from the factory bumper.
- b. Remove the factory sealing washer from the sensor. Attach the provided Foam Sealing Washer to the front of the sensor, **(Figure 13)**.
- c. Push the sensor in from the back of the Bumper until it is flush with the outer Bumper. Attach the adhesive side of (1) Foam Washer to (1) Retaining Clip. Push the Retaining Clip into the sensor sleeve to secure the sensor in place, **(Figure 14)**.
- d. Repeat the previous steps for the remaining sensors.
- e. Attach factory wiring harness to Bumper. **NOTE:** Use the (3) included Wire Harnesses to extend the factory harness to the left outer, left inner and right outer sensors as needed, **(Figure 15)**.

**ELEVATION FRONT BUMPER  
2019 CHEVY SILVERADO 1500  
EXCLUDES 2019 SILVERADO 1500 "LD" CLASSIC**

16. With assistance, position the Bumper Assembly up to the frame. Temporarily support the weight of the Bumper. **WARNING:** To avoid possible injury or damage to the vehicle, do not proceed until the Bumper is fully and safely supported.
17. Line up the driver/left side mounting plate on the back of the Bumper with the Mounting Bracket. Attach the Bumper to the Bracket with the included (3) 12mm Hex Bolts, (6) 12mm Flat Washers and (3) 12mm Nylon Lock Nuts, **(Figures 16 & 17)**. Repeat this **Step** to attach the passenger/right side of the Bumper to the Bracket.
18. Level and adjust the bumper and fully tighten all 12mm hardware to 65-70ft-lbs.
19. Models with grille mounted camera, remove screen from center of Bumper, **(Figure 18)**.
20. **Models with fog lights:**
  - a. Remove fog light assembly from factory bumper.
  - b. Use the included (3) 6mm Hex Bolts, (6) 6mm Flat washers and (3) 6mm Nylon Lock Nuts to attach the driver/left fog light, **(Figures 19 & 20)**. Do not overtighten hardware or damage to the light may result.
  - c. Repeat previous Steps to install the passenger/right fog light.
  - d. Plug wiring harness into lights.
21. If front license plate is required, insert (2) Plastic Plugs into the square holes in the Bumper. Reuse the factory screws to attach the license plate to the plastic plugs, **(Figure 21)**.
22. Do periodic inspections to the installation to make sure that all hardware is secure and tight.

**To protect your investment,** Do not use any type of polish or wax that may contain abrasives that could damage the finish. Mild soap may be used to clean the Front Bumper assembly.

**Driver/left Side Installation Pictured**



**(Fig 1) Remove cover and screws attaching grille**



**(Fig 2) Firmly pull grille straight out from vehicle**

**ELEVATION FRONT BUMPER  
2019 CHEVY SILVERADO 1500  
EXCLUDES 2019 SILVERADO 1500 "LD" CLASSIC**

**Driver/left Side Installation Pictured**

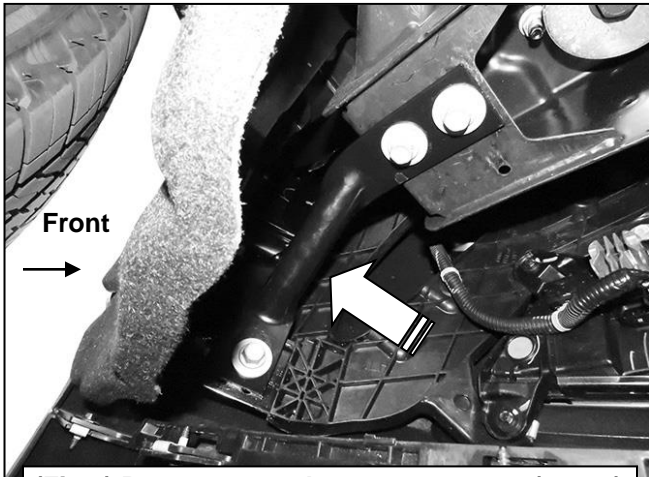

**(Fig 3) Remove outer bumper supports (arrow)**

**WARNING!** Do not crawl under bumper unless the bumper is properly supported on blocks or stands or the bumper may fall.



**(Fig 4) Pull back cover to locate top bumper bolts**

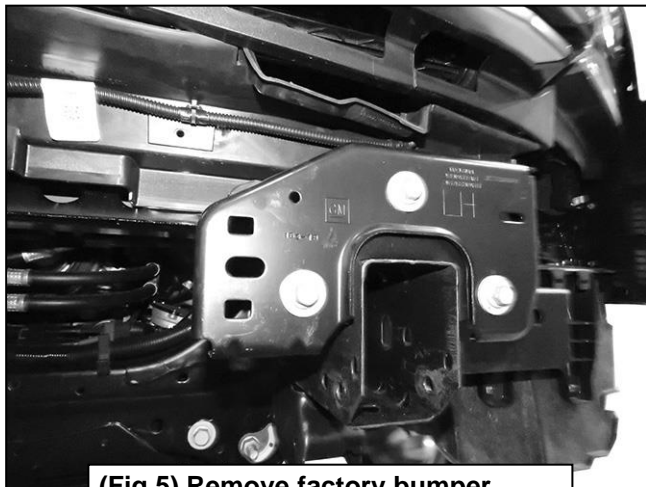

**(Fig 5) Remove factory bumper brackets and tow hooks if equipped**



**(Fig 6) Reinstall grille and cover**

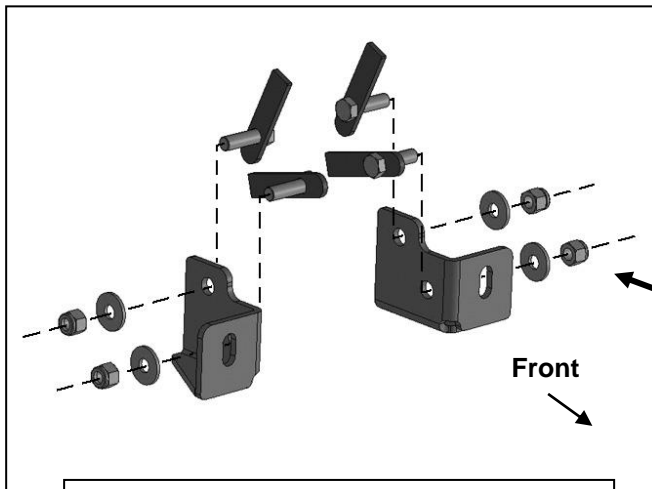

**(Fig 7) Attach Support Brackets to frame**

12mm Bolt Plate  
12mm Flat Washer  
12mm Nylon Lock Nut

**ELEVATION FRONT BUMPER  
2019 CHEVY SILVERADO 1500  
EXCLUDES 2019 SILVERADO 1500 "LD" CLASSIC**

**Driver/left Side Installation Pictured**

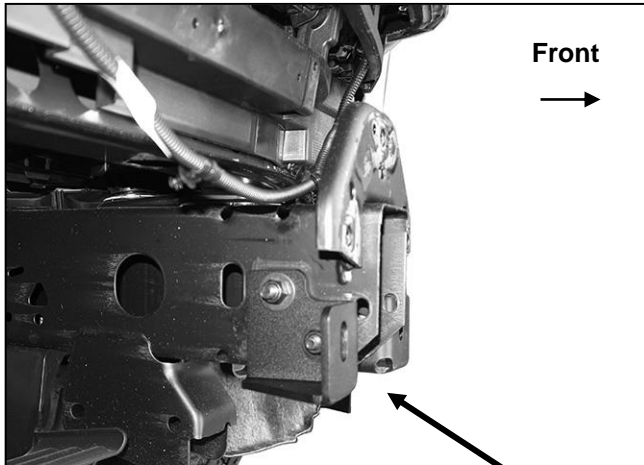

**(Fig 8) Complete installation of Support Brackets**

- (2) 12mm x 50mm Hex Bolts
- (4) 12mm Flat Washers
- (2) 12mm Nylon Lock Nuts

**Reuse Factory bumper bolts**

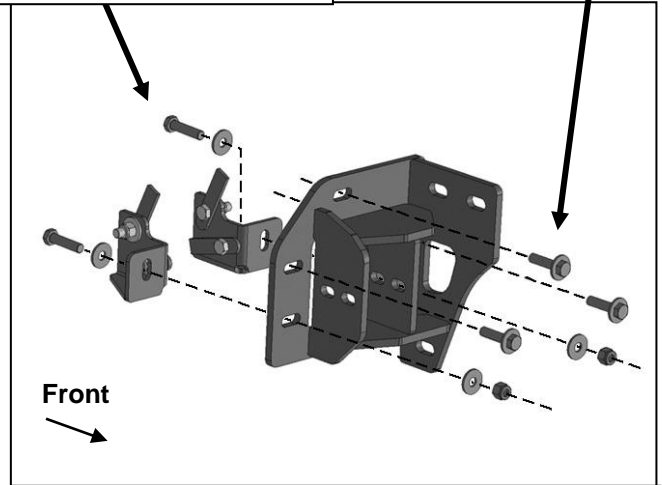

**(Fig 9) Reuse factory bumper bolts to attach top of Frame Bracket to bumper mount on frame**

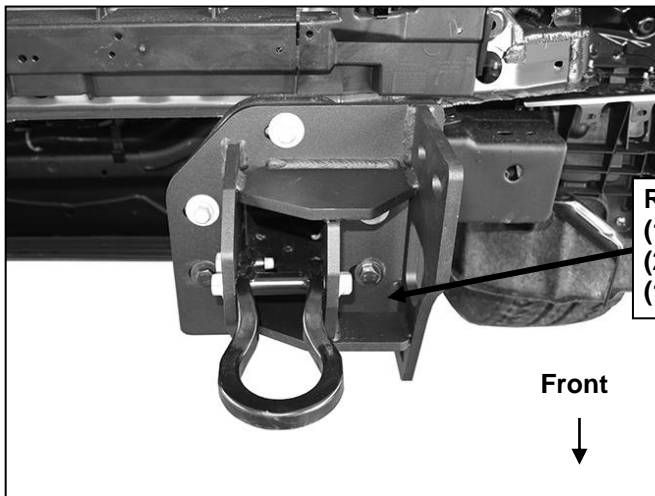

**(Fig 10) Driver/left Bracket and tow hook installed**

- Reuse (1) factory hex bolt
- (1) 12mm x 120mm Hex Bolt
- (2) 12mm Flat Washers
- (1) 12mm Nylon Lock Nut

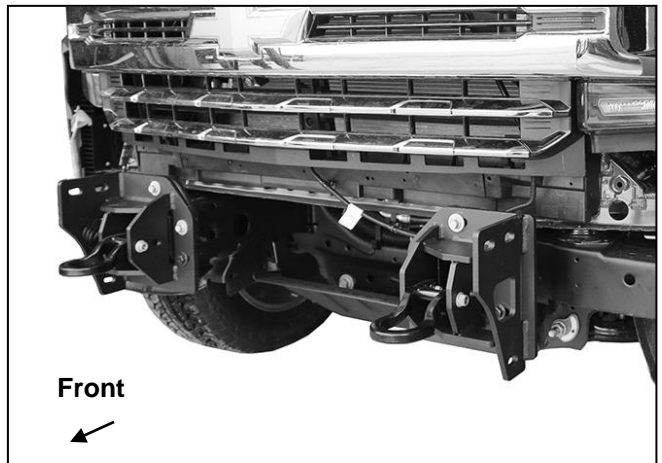

**(Fig 11) Complete installation of Frame Brackets**

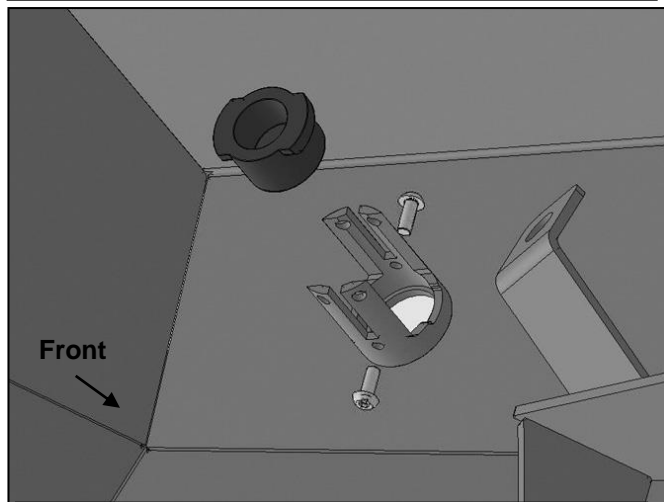

**(Fig 12) Push sensor plug into mounting sleeve**

**ELEVATION FRONT BUMPER  
2019 CHEVY SILVERADO 1500  
EXCLUDES 2019 SILVERADO 1500 "LD" CLASSIC**

**Driver/left Side Installation Pictured**

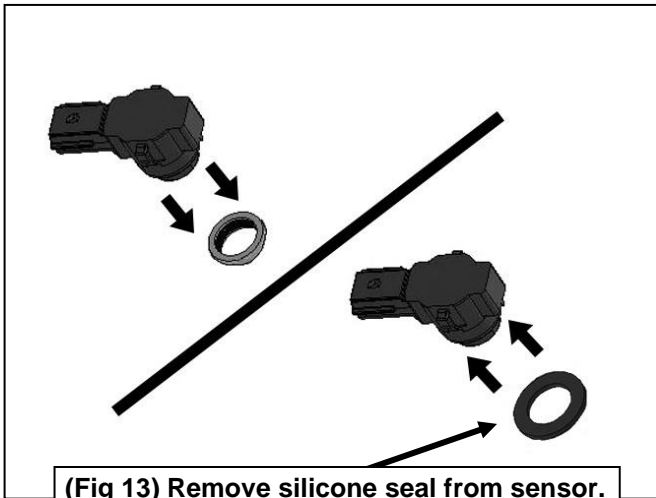

**(Fig 13) Remove silicone seal from sensor. Slide large Seal over end of sensor (arrow)**

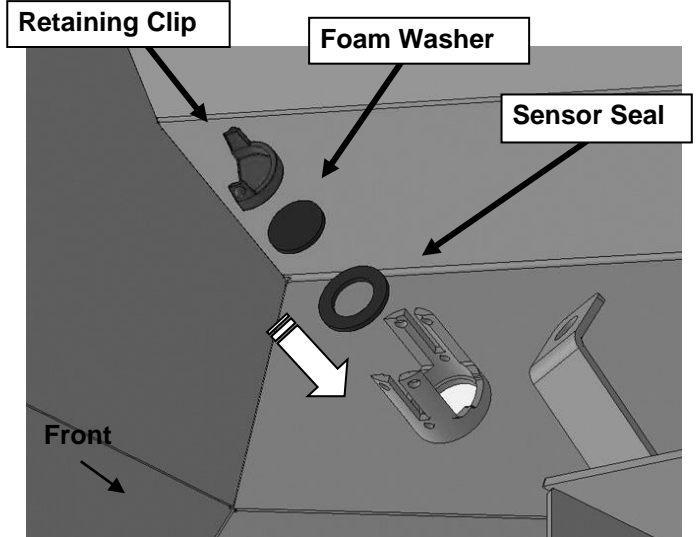

**(Fig 14) Insert sensor assembly through the sensor sleeve on back of Bumper**

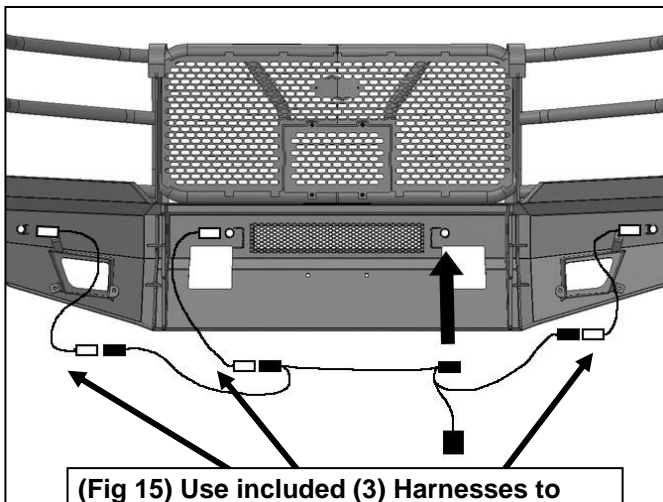

**(Fig 15) Use included (3) Harnesses to extend factory wire harness to sensors**

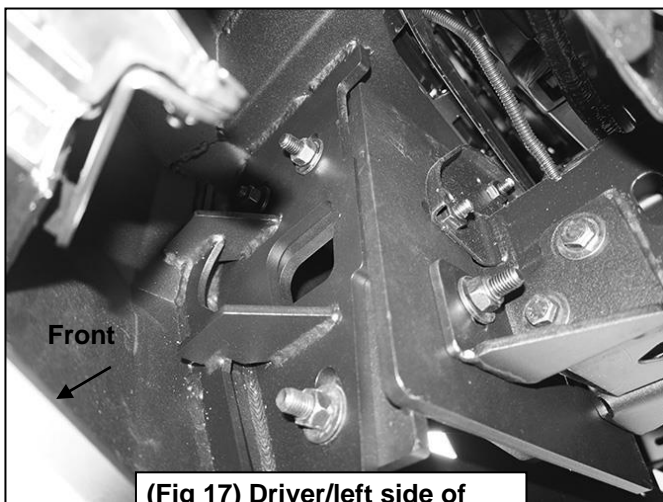

**(Fig 17) Driver/left side of Bumper attached to Bracket**

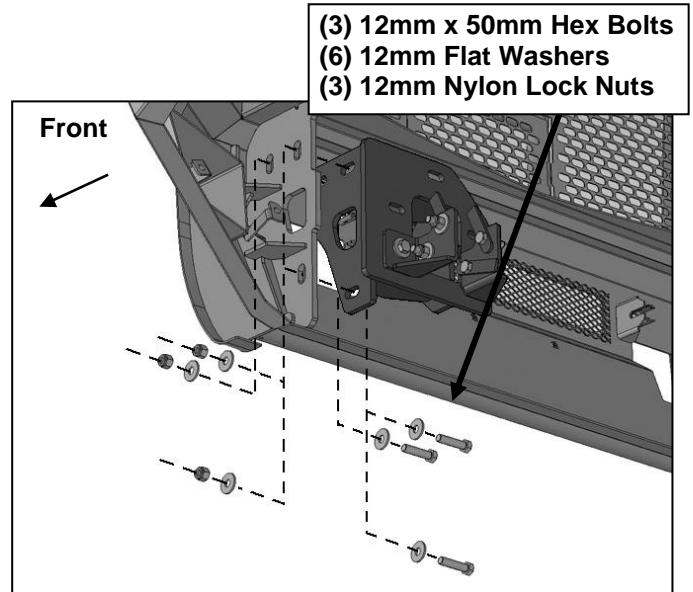

**(Fig 16) Attach the Bumper to Frame Bracket**

**WARNING!** Do not crawl under bumper unless the bumper is properly supported on blocks or stands or the bumper may fall.

**ELEVATION FRONT BUMPER  
2019 CHEVY SILVERADO 1500  
EXCLUDES 2019 SILVERADO 1500 "LD" CLASSIC**

**Driver/left Side Installation Pictured**

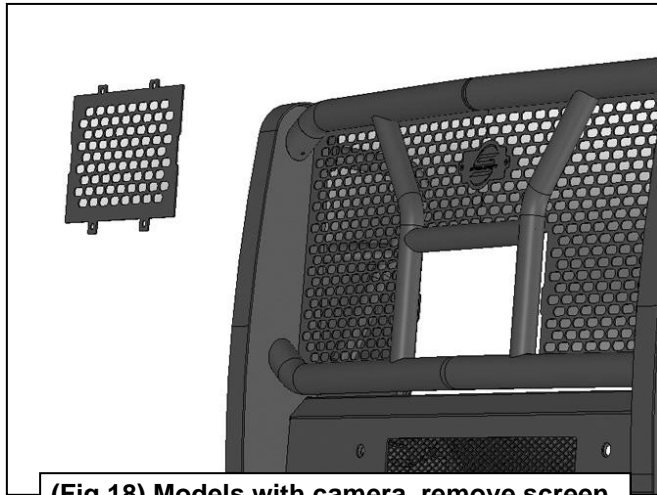

**(Fig 18) Models with camera, remove screen**

- (3) 6mm Hex Bolts**
- (6) 6mm Flat Washers**
- (3) 6mm Nylon Lock Nuts**

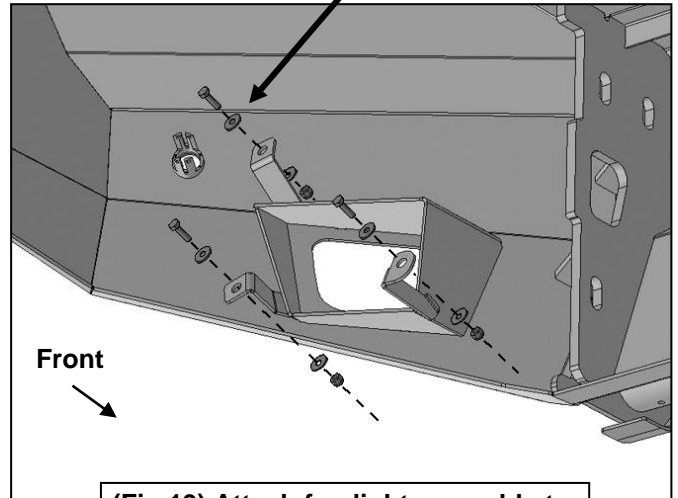

**(Fig 19) Attach fog light assembly to mounting tabs on back of Bumper**

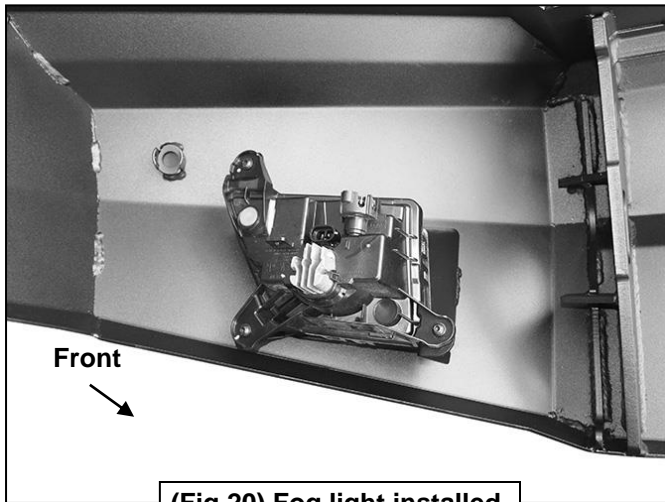

**(Fig 20) Fog light installed**

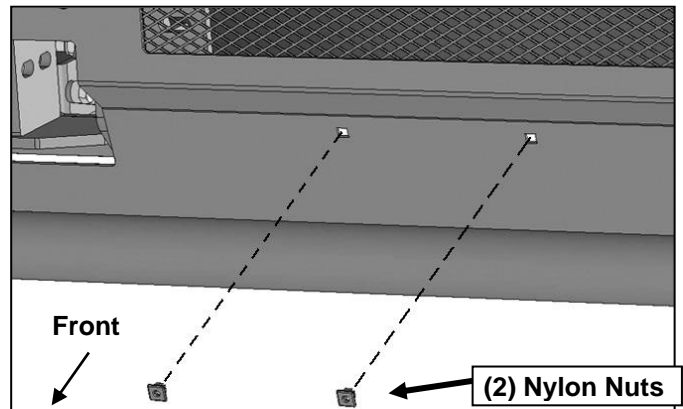

**(Fig 21) Attach License Plate Bracket to Bumper**



**Complete Installation**